



Expanding Your Solutions

Corporate Headquarters
13191 Crossroads Pkwy N., Ste 325
City of Industry, CA 91746
Phone: 800.775.2362
Fax: 626.330.7598

Manufacturing Facilities
City of Industry, CA
Commerce City, CO
Ft. Worth, TX
Pittsburg, CA

Structural Engineering/Design
1001-A Pittsburgh Antioch Hwy
Pittsburg, CA 94565
Phone: 800.775.2362
Fax: 626.330.7598

Technical Services
13191 Crossroads Pkwy N., Ste 325
City of Industry, CA 91746
Phone: 800.416.2278
Fax: 626.249.5004

JAMB-STRUT

Product Description

Jamb-Strut members are fabricated from hot-dipped galvanized steel complying with ASTM A653, with a minimum G40 coating. The framing members comply with ASTM C645. Used with fire and sound rated assemblies listed under the code and Gypsum Association Fire Resistance Design Manual.

Stud Member Depth (in)	Leg Length (in)	Mil (Gauge)
2-1/2", 4", 6"	1" short leg 3" long leg	34 (20)

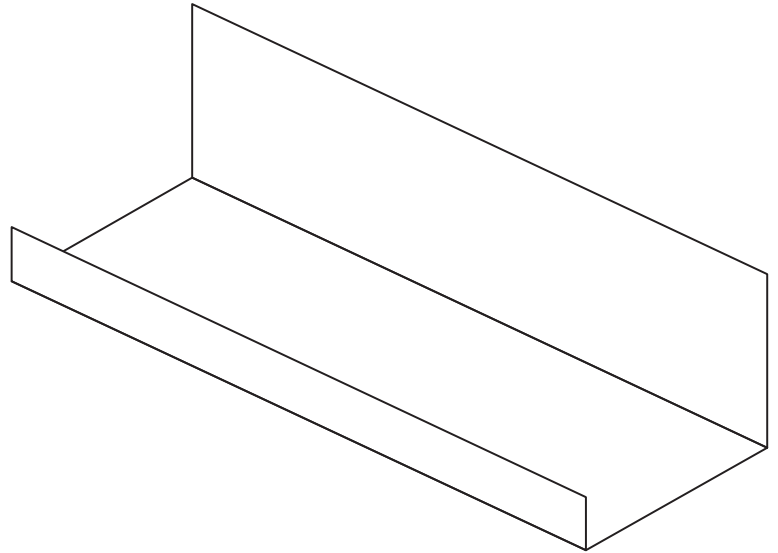

ASTM & Code Standards

- ASTM A653/A653M, A924/A924M, A1003/A1003, C645 & C754
- IBC: 2012, 2015, 2018
- CBC: 2013, 2016, 2019
- AISI: S100-07, S100-12, S100-16, S220-11, S220-15

LEED v4 for Building and Design Construction

By using CEMCO steel framing/metal lath products, your project can contribute to earning LEED points for:

- LEED Credit MR 4.1/4.2 – Recycled Content Requirements (applies for all projects).
- LEED Credit MR 5.1/5.2 Requirements (applies for all projects).

CEMCO cold-formed steel framing products contain 30% to 37% recycled steel

- Total Recycled Content: 36.9%
- Post-Consumer: 19.8%
- Pre-Consumer: 14.4%

Technical Services

Technical Services: 800.416.2278
Structural Engineering/Design: 925.473.9340
www.cemcosteel.com



This technical information reflects the most current information available and supersedes any and all previous publications effective April 1, 2021.

04-01-21 AT