



Expanding Your Solutions

Corporate Headquarters
13191 Crossroads Pkwy N., Ste 325
City of Industry, CA 91746
Phone: 800.775.2362
Fax: 626.330.7598
www.cemcosteel.com

Manufacturing Facilities
City of Industry, CA
Commerce City, CO
Ft. Worth, TX
Pittsburg, CA

Structural Engineering/Design
1001-A Pittsburgh Antioch Hwy
Pittsburg, CA 94565
Phone: 800.775.2362
Fax: 626.330.7598
www.cemcoengineering.com

Technical Services
13191 Crossroads Pkwy N., Ste 325
City of Industry, CA 91746
Phone: 800.416.2278
Fax: 626.249.5004

362S162-118 • C-STUD 118 MIL (10 GA.)

Geometric Properties

362S162-118 "S" structural load-bearing studs are produced from hot-dipped galvanized steel in standard CP60 coating. CP90 is available upon special request, and may require up-charges and extended lead times.

Physical Properties

Model No.	Design Thickness (in.) ¹	Minimum Thickness (in.) ²	Yield (ksi)	Coating ^{3,4}	Web Depth (in)	Flange Size (in)	Lip (in)
362S162-118	0.1242	0.1180	50	CP60	3-5/8	1-5/8	1/2

Notes:

1. Uncoated steel thickness. Thickness is for carbon sheet steel.
2. Minimum thickness represents 95% of the design thickness and is the minimum acceptable thickness.
3. Per ASTM C955 & A1003, Table 1.
4. CP90 available upon request. Will require extended lead time and upcharge.

Color Code (painted on ends): 118-mil: Blue

ASTM & Code Standards:

- ASTM A653/A653M, A924/A924M, A1003/1003, C955 & C1007
- ICC-ES & SFIA Code Compliance Certification Program
- ICC ESR-3016
- ATI CCRR-0224
- IBC: 2015, 2018, 2021
- CBC: 2019, 2022
- AISI: S100, S200, S240

LEED v4 for Building and Design Construction

- MR Prerequisite: Construction and Demolition Waste Management Planning.
- MR Credit: Construction and Demolition Waste Management.
- MR Credit: Building Product Disclosure and Optimization – Sourcing of Raw Materials, Option 2.
- MR Credit: Building Product Disclosure and Optimization – Environmental Product Declarations, Options 1 & 2.
- MR Credit: Building Product Disclosure and Optimization – Material Ingredients, Option 1.
- MR Credit: Building Life-Cycle Impact Reduction, Option 4.

CEMCO cold-formed steel framing products contain 30% to 37% recycled steel.

- Total Recycled Content: 36.9%
- Post-Consumer: 19.8%
- Pre-Consumer: 14.4%

CSI Division: 05.40.00 – Cold-Formed Metal Framing

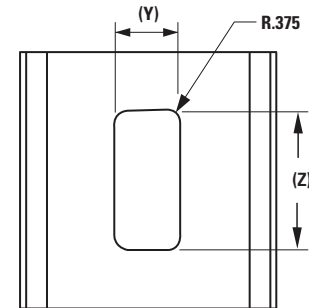
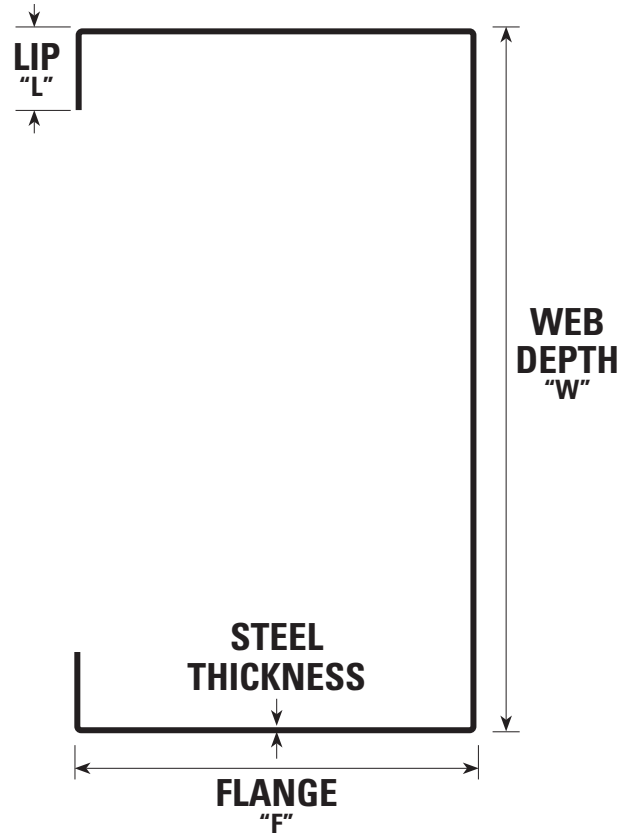

Hole Detail

Standard hole centers are 24"	(Z) (in)	(Y) (in)
2-1/2" studs	2.000"	0.750"
3-1/2" to 14" stud	3.250"	1.500"

362S162-118 Section Properties

Design Thickness (in.)	Fy (ksi)	Gross ³					Effective Properties ²						Torsional Properties						Lu (in)
		Ix (in ⁴)	Sx (in ³)	Rx (in)	Iy (in ⁴)	Ry (in)	Ix (in ⁴)	Sx (in ³)	Ma (in-k)	Vag (lb)	Vanet (lb)	Mad (in-k)	Jx1000 (in ⁴)	Cw (in ⁶)	Xo (in)	m (in)	Ro (in)	β	
0.1242	50	1.672	0.923	1.392	0.273	0.562	1.672	0.923	33.05	6996	784	33.76	4.440	0.828	-1.198	0.731	1.920	0.611	31.1

Notes: 1. Web depth for track sections equals nominal depth plus 2 times the design thickness plus bend radius. 2. The values are for members with punch-outs. 3. Gross properties are based on the full, unreduced cross-section, away from web punchouts. 4. Use the effective moment of inertia for deflection calculation. 5. Allowable moment is lesser of Ma and Mad. Distortional buckling is based on an assumed $K\phi = 0$. 6. These members are available un-punched only.

Check the updated list of Certified Production Facilities at Intertek's website at <http://www.intertek.com/building/sfia>



This technical information reflects the most current information available and supersedes any and all previous publications effective May 1, 2024.

05/01/2024 AT