

ICC-ES Evaluation Report

ESR-2049

Reissued December 2025

This report also contains:

- CA Supplement w/DSA and OSHPD

Subject to renewal December 2026

- FL Supplement w/HVHZ

ICC-ES Evaluation Reports are not to be construed as representing aesthetics or any other attributes not specifically addressed, nor are they to be construed as an endorsement of the subject of the report or a recommendation for its use. There is no warranty by ICC Evaluation Service, LLC, express or implied, as to any finding or other matter in this report, or as to any product covered by the report.

Copyright © 2025 ICC Evaluation Service, LLC. All rights reserved.

<p>DIVISION: 05 00 00—METALS</p> <p>Section: 05 05 23—Metal Fastenings</p> <p>Section: 05 40 00—Cold-Formed Metal Framing</p> <p>DIVISION: 09 00 00—FINISHES</p> <p>Section: 09 22 16.13—Non-Structural Metal Stud Framing</p>	<p>REPORT HOLDER:</p> <p>THE STEEL NETWORK, INC.</p>	<p>EVALUATION SUBJECT:</p> <p>VERTICLIP®, DRIFTCLIP®, AND DRIFTTRAK® EXTERIOR CURTAIN WALL AND INTERIOR TOP-OF-WALL STEEL STUD CONNECTORS</p>	
---	--	---	---

1.0 EVALUATION SCOPE

Compliance with the following code:

- 2021, 2018, 2015, 2012 and 2009 [International Building Code® \(IBC\)](#)
- 2013 *Abu Dhabi International Building Code (ADIBC)*[†]

[†]The ADIBC is based on the 2009 IBC. 2009 IBC code sections referenced in this report are the same sections in the ADIBC.

Property evaluated:

- Structural

2.0 USES

2.1 VertiClip® Exterior Curtain Wall Connectors:

The VertiClip® SL, SLB, SLS, and SLT cold-formed steel connectors are used to attach the steel studs of a building’s exterior curtain wall to structural members, and are designed to transfer wind or seismic loads acting perpendicular to the exterior curtain wall and accommodate vertical movement between exterior wall elements and the primary structure.

2.2 DriftClip® and DriftTrak® Exterior Curtain Wall Connectors:

The DriftClip® DSLB, DSLS, and DSL, and DriftTrak® DTSLB and DTSL cold-formed steel connectors are used to attach the steel studs of a building’s exterior curtain wall to structural members, to transfer wind or seismic loads acting perpendicular to the exterior curtain wall and to accommodate vertical movement and horizontal (in-plane of wall) movement between exterior wall elements and the primary structure.

2.3 VertiClip® Interior Top-of-wall Connector:

The VertiClip® SLD cold-formed steel connector is used to attach the top of interior nonload-bearing steel studs (top-of-wall connection) to the building’s structural floor/ceiling or roof/ceiling deck, and is designed to transfer loads acting perpendicular to the interior nonload-bearing wall and to accommodate vertical movement of the building’s floor/ceiling or roof/ceiling deck.

2.4 DriftClip® Interior Top-of-wall Connector:

The DriftClip® DSLD cold-formed steel connector is used to attach the top of interior nonload-bearing steel studs (top-of-wall connection) to the building's structural floor/ceiling or roof/ceiling deck, to transfer loads acting perpendicular to the interior nonload-bearing wall and to accommodate vertical movement and horizontal (in-plane of wall) movement of the building's floor/ceiling or roof/ceiling deck.

3.0 DESCRIPTION

3.1 VertiClip® SL, SLB, SLS, and SLT Exterior Curtain Wall Stud Connectors:

3.1.1 General: VertiClip® model numbers correspond to the depth of the cold-formed steel stud attached to the VertiClip; e.g., a VertiClip connector with a model number 362 is designed to be attached to a $3\frac{5}{8}$ inch deep (92 mm) steel stud, where the depth of the steel stud is rounded to 3.62 and is reported as 362. Each VertiClip exterior curtain wall stud connector has two or more vertical slots with factory-installed bushings located in the center of each slot, through which a #12 self-drilling/self-tapping steel screw is installed to attach the clip to the stud, allowing horizontal loads to be transferred from the stud web to the supporting structure while allowing vertical movement of the structure with negligible friction. The Steel Network, Inc., supplies the required number of screws with each clip for attachment to steel studs. Fasteners used to attach the clips to the supporting structure must be designed and specified by a registered design professional and not supplied by The Steel Network, Inc.

3.1.2 VertiClip® SL: VertiClip® SL362, 600 and 800 are L-shaped angles that connect $3\frac{5}{8}$, 6 and 8 inch deep (92, 152, and 203 mm) exterior curtain wall steel studs, respectively, at head of wall to the building's structural frame while allowing for a maximum of $1\frac{1}{2}$ inches (38.1 mm) of vertical movement between exterior wall elements and the primary structure. The minimum base-metal thickness of the clips is 0.0677 inch (1.7 mm). The long leg of the VertiClip SL362, SL600 and SL800 connectors, which is fastened to the curtain wall stud, has two or three vertical slots, each $\frac{3}{8}$ inch (9.5 mm) wide by $1\frac{7}{8}$ inches (47.6 mm) long. Refer to [Figure 1](#) for overall dimensions of each VertiClip SL connector and a typical installation detail.

3.1.3 VertiClip® SLB: The VertiClip® SLB600 is an L-shaped angle that connects 6 inch deep (152 mm) exterior curtain wall steel studs to a concrete floor slab's pour stop angle while allowing a maximum of 2 inches (51 mm) of vertical movement between exterior wall elements and the primary structure. The minimum base-metal thickness of the clip is 0.0677 inch (1.7 mm). The long leg of the connector, which is fastened to the curtain wall stud, has three vertical slots, each $\frac{3}{8}$ inch (9.5 mm) wide by $2\frac{3}{8}$ inches (60.3 mm) long. Refer to [Figure 2](#) for overall dimensions of the VertiClip SLB600 connector and a typical installation detail.

3.1.4 VertiClip® SLS: The VertiClip® SLS600–12 is an L-shaped angle that connects 6 inch deep (152 mm) exterior curtain walls to a building's structural steel spandrel beam or structural concrete floor slab, while allowing for a maximum of $1\frac{1}{2}$ inches (38 mm) of vertical movement between exterior wall elements and the primary structure. The minimum base-metal thickness of the clip is 0.0677 inch (1.7 mm). The designation “–12”, following the model number SLS600, represents the total length, in inches, of the connector. The end of the connector that is attached to the curtain wall framing members has two or three vertical slots, each $\frac{3}{8}$ inch (9.5 mm) wide by $1\frac{7}{8}$ inches (47.6 mm) long. Refer to [Figure 3](#) for overall dimensions of the VertiClip SLS600–12 connector and a typical installation detail.

3.1.5 VertiClip® SLT: VertiClip® SLT–9.5 and SLT(L)–18 are formed steel plates having one upward and one downward vertical leg at the end of the connectors that attach to the curtain wall framing members. The minimum base-metal thickness of the plates is 0.0966 inch (2.5 mm). Each leg of the SLT–9.5 is $1\frac{1}{2}$ inches (38 mm) wide by $2\frac{1}{4}$ inches (57 mm) high, and has one vertical slot measuring $\frac{5}{16}$ inch (8 mm) wide by $1\frac{3}{8}$ inches (35 mm) long, allowing for a maximum 1-inch (25.4 mm) vertical movement of the framing members. Each leg of the SLT(L)–18 is $2\frac{13}{16}$ inches (71 mm) wide by $3\frac{1}{8}$ inches (79 mm) high, and has two vertical slots measuring $\frac{3}{8}$ inch (9.5 mm) wide by $2\frac{1}{4}$ inches (57 mm) long, allowing for a maximum of $1\frac{7}{8}$ inches (47.6 mm) of vertical movement between exterior wall elements and the primary structure. The bend in the steel plate at the vertical legs of the SLT(L)–18 is reinforced with two $\frac{3}{8}$ -inch-by- $\frac{5}{8}$ -inch (9.5 mm by 15.9 mm) L-shaped steel angles that are factory-attached with four $\frac{3}{16}$ -inch-diameter (4.8 mm) rivets. The angle reinforcement is $4\frac{3}{8}$ inches (111 mm) long and has a minimum base-metal thickness of 0.0677 inch (1.7 mm). Refer to [Figure 4](#) for overall dimensions of the VertiClip SLT–9.5 and SLT(L)–18 connectors and a typical installation detail.

3.2 VertiClip® SLD Interior Wall Stud Connector:

The VertiClip® SLD600 is an L-shaped angle that connects the top end of 6 inch deep (152 mm) interior wall steel studs to a metal deck above, while allowing for a maximum $1\frac{1}{2}$ -inch (38 mm) vertical movement. The

minimum base-metal thickness of the clip is 0.0329 inch (0.8 mm). The long leg of the VertiClip SLD600 connector, which is fastened to the web of the interior wall steel stud, has two vertical slots, each $\frac{3}{8}$ inch (9.5 mm) wide by $\frac{17}{8}$ inches (47.6 mm) long. Each vertical slot has a factory-installed bushing located in the center of the slot, through which a #8 self-drilling, self-tapping steel screw is installed to attach the clip to the stud, allowing horizontal loads to be transferred from the stud web to the supporting structure while permitting vertical movement of the structure with negligible friction. The Steel Network, Inc., supplies the required number of steel screws with each clip for attaching it to the steel studs. Refer to [Figure 5](#) for overall dimensions of the VertiClip SLD600 connector and a typical installation detail.

3.3 DriftClip® DSLB, DSLS, and DSL and DriftTrak® DTSLB and DTSL, Exterior Curtain Wall Stud Connector:

3.3.1 General: DriftClip® and DriftTrak® model numbers correspond to the depth of the cold-formed steel stud attached to the DriftClip or DriftTrak. For example, a DriftClip connector with a model number 362 is designed to be attached to a $3\frac{5}{8}$ inch deep (92 mm) steel stud, where the depth of the steel stud is rounded to 3.62 inches (92 mm) and is reported as 362. Each DriftClip and DriftTrak exterior stud connector has two or more vertical slots with factory-installed bushings located in the center of each slot, through which a #12, self-drilling/self-tapping steel screw supplied by the Steel Network, Inc., is installed to attach the clip to the stud, allowing horizontal loads to be transferred from the stud web to the supporting structure while allowing vertical movement of the structure with negligible friction. Each DriftClip also has two or more horizontal slots with factory-installed bushings located in the center of each slot, through which a $\frac{1}{4}$ -inch-diameter (6.4 mm) fastener designed and specified by a registered design professional, and not supplied by the Steel Network, Inc., is installed to attach the clip to the structure, allowing horizontal loads to be transferred from the stud web to the supporting structure while allowing horizontal (in-plane of wall) movement of the structure with negligible friction. DriftTrak consists of a clip that slides into a track component that is attached to the structure fasteners designed and specified by a registered design professional, not supplied by the Steel Network Inc., that allows the clip component to move freely in-plane along the track allowing horizontal loads to be transferred from the stud web to the supporting structure while allowing horizontal (in-plane of wall) movement of the structure with negligible friction.

3.3.2 DriftClip® DSLB: DriftClip® DSLB362/400, 600 and 800 are L-shaped angles that connect $3\frac{5}{8}$ - or 4-, 6- and 8-inch-deep (92 or 102, 152, and 203 mm) exterior curtain wall steel studs, respectively, to a concrete floor slab's pour stop angle while allowing a maximum of 2 inches (51 mm) of vertical and horizontal movement between exterior wall elements and the primary structure. The minimum base-metal thickness of the clips is 0.0966 inch (2.5 mm). The leg which matches the wall depth and is fastened to the curtain wall stud has two or three slots parallel to the heel of the angle, each $\frac{3}{8}$ inch (9.5 mm) wide by $2\frac{3}{8}$ inches (60 mm) long with a bushing designed for #12 self-drilling/self-tapping steel screws to be installed in the centers of the slots. The $3\frac{3}{4}$ inches (95 mm) leg, which is fastened to the structure, has bushings designed for $\frac{1}{4}$ inch diameter (6.4 mm) fasteners to be installed in the centers of each slot. Refer to [Figure 6](#) for overall dimensions of each DriftClip DSLB connector and a typical installation detail.

3.3.3 DriftClip® DSLS: DriftClip® DSLS600-12 and DSLS600-15 are L-shaped angles that connect 6 inch deep (152 mm) cold-formed steel framing of exterior curtain walls to a building's structural steel spandrel beam or structural concrete floor slab, while allowing a maximum of 2 inches (51 mm) of vertical and horizontal movement between curtain wall elements and the primary structure. The minimum base-metal thickness of the clips is 0.0966 inch (2.5 mm). The -12 and -15 following the model number DSLS600 represent the total length, in inches, of the connector. The two legs of the DriftClip DSLS600-12 and -15 connectors are equal in length, and each has two or three slots perpendicular to the heel of the angle, each $\frac{3}{8}$ inch (9.5 mm) wide by $2\frac{3}{8}$ inches (60 mm) long. The leg that is fastened to the curtain wall stud has bushings designed for #12 self-drilling/self-tapping steel screws installed in the centers of the slots. The other leg, which is fastened to the structure, has bushings designed for $\frac{1}{4}$ -inch diameter (6.4 mm) fasteners installed in the centers of the slot. Refer to [Figure 7](#) for overall dimensions of each DriftClip DSLS connector and a typical installation detail.

3.3.4 DriftClip® DSL: DriftClip® DSL362/400, 600 and 800 are L-shaped angles that connect $3\frac{5}{8}$ or 4, 6 and 8 inch deep (92 or 102, 152, and 203 mm) exterior curtain wall steel studs, respectively, at the head of wall to the building's structural frame while allowing for a maximum of 2 inches (51 mm) of vertical, and horizontal movement between exterior wall elements and the primary structure. The minimum base-metal thickness of the clips is 0.0966 inch (2.5 mm). The two legs of the DriftClip DSL362/400, 600 and 800 connectors are equal in length, and each has two or three slots perpendicular to the heel of the angle, each $\frac{3}{8}$ inch (9.5 mm) wide by $2\frac{3}{8}$ inches (60 mm) long. The leg that is fastened to the curtain wall stud has bushings designed for #12 self-drilling/self-tapping steel screws installed in the center of each slot. The other leg, which is fastened

to the structure, has bushings designed for $\frac{1}{4}$ inch diameter (6.4 mm) fasteners installed in the centers of the slots. Refer to [Figure 8](#) for overall dimensions of each DriftClip DSL connector and a typical installation detail.

3.3.5 DriftTrak® DTSLB: DriftTrak® DTSLB362/400, 600 and 800 are L-shaped angle and track combinations that connect $3\frac{5}{8}$ or 4, 6 and 8 inch deep (92 or 102, 152, and 203 mm) exterior curtain wall steel studs, respectively, to a concrete floor slab's pour-stop angle while allowing a maximum of 2 inches (51 mm) of vertical movement, and free horizontal movement between exterior wall elements and the primary structure. The minimum base-metal thickness of the clip is 0.0677 inch (1.7 mm), and the minimum base-metal thickness of the track is 0.0966 inch (2.5 mm). The long leg of the DriftTrak DTSLB connector, which is fastened to the curtain wall stud, has two or three vertical slots, each $\frac{3}{8}$ inch (9.5 mm) wide by $2\frac{3}{8}$ inches (60 mm) long and has bushings designed for #12 self-drilling/self-tapping steel screws installed in the centers of the slots. Refer to [Figure 9](#) for overall dimensions of each DriftTrak DTSLB connector and a typical installation detail.

3.3.6 DriftTrak® DTSL: The DriftTrak® DTSL is an L-shaped angle and track combination that connects exterior curtain wall steel studs of various depths at the head of wall to the building's structural frame while allowing for a maximum of 2 inches (51 mm) of vertical movement, and free horizontal movement between exterior wall elements and the primary structure. The minimum base-metal thickness of the clip is 0.0677 inch (1.7 mm) and the minimum base-metal thickness of the track is 0.0966 inch (2.5 mm). The long leg of the DriftTrak DTSL connector, which is fastened to the curtain wall stud, has two vertical slots, each $\frac{3}{8}$ inch (9.5 mm) wide by $2\frac{3}{8}$ inches (60 mm) long, and has bushings designed for #12 self-drilling/self-tapping steel screws installed in the centers of the slots. Refer to [Figure 10](#) for overall dimensions of each DriftTrak DTSL connector and a typical installation detail.

3.4 DriftClip® DSLD Interior Top-of-Wall Stud Connectors:

DriftClip® DSLD362/400, 600 and 800 are L-shaped angles that connect $3\frac{5}{8}$ or 4, 6 and 8 inch deep (92 or 102, 152, and 203 mm) interior wall steel studs, respectively, at the head of wall to a metal deck above, while allowing for a maximum of 2 inches (51 mm) of vertical movement, and horizontal (in-plane of wall) movement between interior wall elements and the primary structure. The minimum base-metal thickness of the clips is 0.0329 inch (0.8 mm). The two legs of the DriftClip DSLD362/400, 600 and 800 connectors are equal in length, and each has two or three slots perpendicular to the heel of the angle, each $\frac{3}{8}$ inch (9.5 mm) wide by $2\frac{3}{8}$ inches (60 mm) long, with bushings designed for #8 self-drilling/self-tapping steel screws installed in the centers of the slots. Refer to [Figure 11](#) for overall dimensions of each DriftClip DSLD connector and a typical installation detail.

3.5 Materials:

3.5.1 VertiClip®, DriftClip® and DriftTrak®: The VertiClip®, DriftClip® and DriftTrak® connectors described in this report are manufactured from ASTM A1003/1003M-15 Structural Grade 50 (ST50H) steel.

There is a minimum G90 zinc-coating designation for VertiClip SL, SLB, SLS, and SLT Exterior Curtain Wall Stud Connectors, and a minimum G60 zinc-coating designation for the VertiClip® SLD600 Interior Wall Stud Connector.

There is a minimum G90 zinc-coating designation for DriftClip® DSL, DSLB, DSLS and the clip component of the DriftTrak DTSL and DTSLB Exterior Curtain Wall Stud Connectors, and a minimum G60 zinc-coating designation for the DriftClip DSLD Interior Curtain Wall Stud Connectors and the track component of the DriftTrak DTSL and DTSLB.

3.5.2 Bushings: The bushings are proprietary and factory-installed on each VertiClip®, DriftClip® and DriftTrak® product, and are not available separately for field installation.

The bushings through which the attachment to the stud is made for all VertiClip, DriftClip and DriftTrak clips are manufactured from carbon steel conforming to ASTM B783-19, F-0008-35 or ASTM A576-90b (2012), Grade 1008/1010 as stipulated in the approved quality-control manual.

The bushings through which the attachment to the structure is made for DriftClip DSLD are manufactured from carbon steel conforming to ASTM B783-19, F-0008-35 or ASTM A576-90b (2012), Grade 1008/1010 as stipulated in the approved quality control manual.

The bushings through which the attachment to the structure is made for DriftClip DSL, DSLB, and DSLS are manufactured from ASTM A576-90b (2012), Grade 12L14 steel as stipulated in the approved quality control manual.

3.5.3 Screws: Screws used with VertiClip®, DriftClip® and DriftTrak® series for the attachment to the stud must be self-drilling/self-tapping steel screws, as follows:

- a. The #8 self-drilling/self-tapping metal screws used with the VertiClip SLD600 must have a minimum nominal screw shear strength, P_{ss} , of 1,340 pounds.
- b. The #12 self-drilling/self-tapping metal screws used with the VertiClip SLS600–12, SLB600, SL362, SL600, SL800, SLT–9.5 and SLT(L)–18 must have a minimum nominal screw shear strength, P_{ss} , of 2,150 pounds.
- c. The #8 self-drilling/self-tapping screws used with the DriftClip DSLD362/400, DSLD600, and DSLD800 must have a minimum nominal screw shear strength, P_{ss} , of 1,330 pounds.
- d. The #12 self-drilling/self-tapping screws used with the DriftClip DSLB362/400, DSLB600, DSLB800, DSLS600-12, DSLS600-15, DSL362/400, DSL600, DSL800, and DriftTrak DTSLB362/400, DTSLB600, DTSLB800 and DTSL, must have a minimum nominal screw shear strength, P_{ss} , of 2,150 pounds.

3.5.4 Cold-formed Steel Studs: The available strength loads specified in [Table 1](#) are applicable to connections with steel studs fabricated from cold-formed steel complying with ASTM A1003/A 1003M-15 Grade ST50H, having a minimum base-metal thickness of 0.0966 inch (2.5 mm).

4.0 DESIGN AND INSTALLATION

Installation of the VertiClip®, DriftClip® and DriftTrak® products must comply with this report and the manufacturer's published installation instructions. See footnotes to [Table 1](#) for design requirements.

5.0 CONDITIONS OF USE:

The VertiClip®, DriftClip® and DriftTrak® products described in this report comply with, or are suitable alternatives to what is specified in, those codes listed in Section 1.0 of this report, subject to the following conditions:

- 5.1 Drawings and design details verifying compliance with this report must be submitted to the building official for approval. The drawings and calculations must be prepared by a registered design professional when required by the statutes of the jurisdiction in which the project is to be constructed.
- 5.2 The products must be installed in accordance with this report and the manufacturer's published installation instructions. If there is a conflict between this report and the manufacturer's published installation instructions, this report governs.

6.0 EVIDENCE SUBMITTED

Data in accordance with the [ICC-ES Acceptance Criteria for Connectors Used with Cold-formed Steel Structural Members \(AC261\)](#), dated February 2019 (editorially revised December 2020).

7.0 IDENTIFICATION

- 7.1 The VertiClip®, DriftClip® and DriftTrak® products described in this report must be stamped, labeled, or inked with the product designation and the company name (The Steel Network, Inc., or TSN). Each box label must include the company name (The Steel Network, Inc.), product designation/part name, quantity, the ICC-ES evaluation report number (ESR-2049), and a traveler (tracing) number.
- 7.2 The report holder's contact information is the following:

THE STEEL NETWORK, INC.
2012A T.W. ALEXANDER DRIVE
POST OFFICE BOX 13887
DURHAM, NORTH CAROLINA 27709
(919) 845-1025
www.steelnetwork.com
support@steelnetwork.com

TABLE 1—VERTICLIP® DRIFTCLIP® AND DRIFTTRAK® ALLOWABLE STRESS DESIGN (ASD), LOAD RESISTANCE FACTOR DESIGN (LRFD) STRENGTH, AND DEFLECTION SERVICE LIMIT LOADS^{1,2,3,7}

MODEL	SCREWS TO STUD (Quantity) AND SIZE ⁴	FIGURE	ASD ALLOWABLE STRENGTH ⁵ (lbs)	LRFD DESIGN STRENGTH ⁵ (lbs)	SERVICE LIMIT LOAD (lbs) ⁶
VertiClip®					
SL362	(2) #12	1	790	1,700	790
SL600	(3) #12	1	1,680	2,690	3,440
SL800	(3) #12	1	1,870	2,990	4,570
SLB600	(3) #12	2	1,600	2,560	1,680
SLS600-12	(3) #12	3	2,070	3,315	3,240
SLT-9.5	(2) #12	4	510	820	1,280
SLT(L)-18	(4) #12	4	700	1,120	1,440
SLD600	(2) #8	5	405	650	1,170
DriftClip®					
DSL362/400, 600, 800	(2) #12 for DSL362/400 (3) #12 for DSL600, 800	6	572	916	735
DSLS600-12	(3) #12	7	1,742	2,787	2,084
DSLS600-15	(3) #12	7	1,903	3,044	2,958
DSL362/400	(2) #12	8	248	397	129
DSL600	(3) #12	8	776	1,241	418
DSL800	(3) #12	8	1,041	1,665	1,510
DSL362/400	(2) #8	11	53	85	27
DSL600	(2) #8	11	178	285	107
DSL800	(2) #8	11	183	294	325
DriftTrak®					
DTSL362/400, 600, 800	(2) #12 for DTSL362/400 (3) #12 for DTSL600, 800	9	808	1,293	1,304
DTSL	(2) #12	10	482	771	492

For SI: 1 lbf = 4.45 N.

Notes to Table 1:

¹Refer to [Figures 1](#) through [11](#) for direction of load.

²Tabulated values are only applicable for the connection of the VertiClip®, DriftClip® and DriftTrak® connectors to the cold-formed steel stud. The connection of the VertiClip, DriftClip and DriftTrak connectors to the supporting structure must have a design strength (LRFD) or allowable strength (ASD) not less than the design force for the connection to the cold-formed steel stud.

³If the steel studs connected to VertiClip®, DriftClip® and DriftTrak® connectors have lower base-metal thickness or material strength values than specified in Section 3.5.4, the ASD allowable strength or the LRFD design strength of the steel-stud/connector-screw connection may be calculated according to the AISI cold-formed steel specification referenced by the AISI S100-16(2020) w/S2-20 under the 2021 IBC, AISI S100-16 under the 2018 IBC, AISI S100-12 under the 2015 IBC, AISI S100-07/S-02 under the 2012 IBC or AISI S100-07 under the 2009 IBC, but not to exceed the corresponding loads listed in [Table 1](#).

⁴Screws must comply with Section 3.5.3 of this report, and must be installed in the pre-punched holes and bushings provided in the connectors.

⁵When using the alternate basic load combinations in 2021 IBC Section 1605.2 (2018, 2015, 2012 and 2009 IBC Section 1605.3.2) that include wind or seismic loads, the tabulated ASD allowable strength for the DriftClip® and DriftTrak® connectors may not be increased by 33¹/₃ percent, nor must the alternative basic load combinations be reduced by a factor of 0.75. When using the basic load combinations in accordance with 2021 IBC Section 1605.1 (2018, 2015, 2012 and 2009 IBC Section 1605.2.1), the LRFD design strength in [Table 1](#) for the DriftClip® and DriftTrak® connectors must not be increased for wind or seismic loading.

⁶The Service Limit Load is the average test load at a ³/₁₆-inch deflection service limit for DriftClip® (DSLS, DSL, DSLD, and DSLB) connectors and the average test load at a ¹/₈-inch deflection service limit for VertiClip® (SL, SLB, SLD, SLS and SLT) and DriftTrak® (DTSLB and DTSL) connectors. The service limit is applicable to both ASD and LRFD.

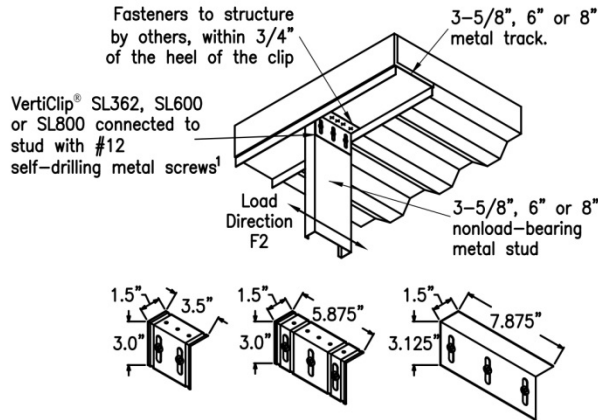

Figure 1 – VertiClip® SL362/400, SL600 and SL800

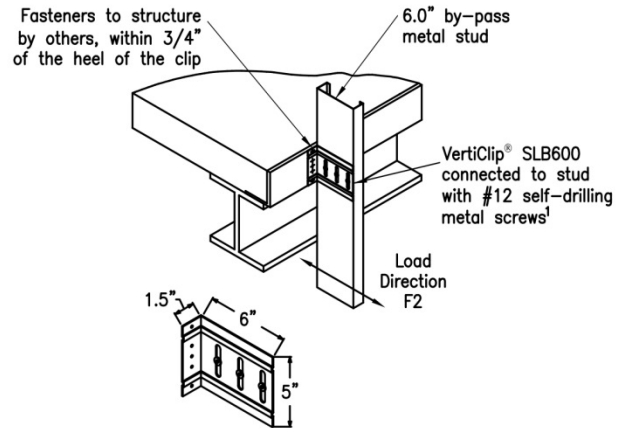

Figure 2 – VertiClip® SLB600

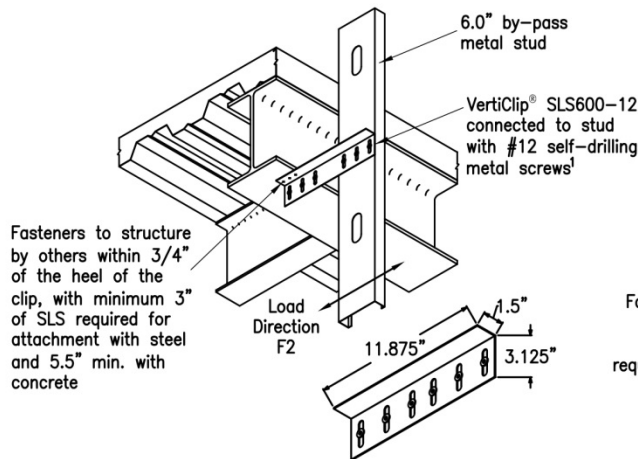

Figure 3 – VertiClip® SLS600-12

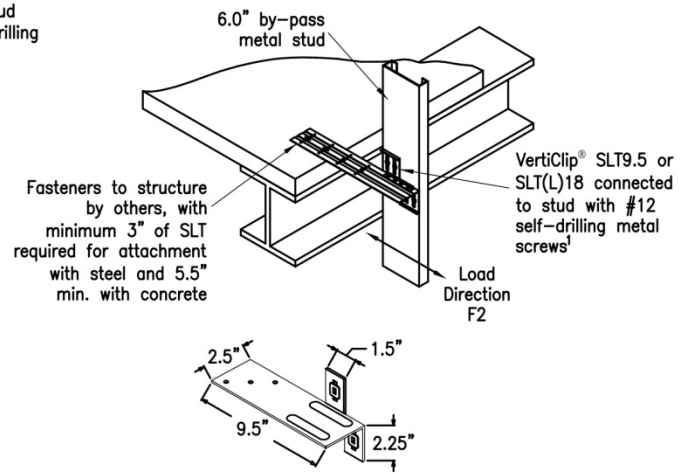

Figure 4 – VertiClip® SLT-9.5 and SLT(L)18

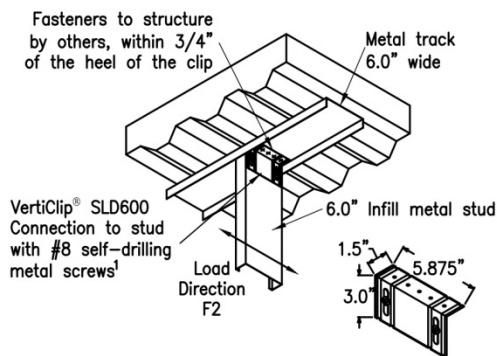

Figure 5 – VertiClip® SLD600

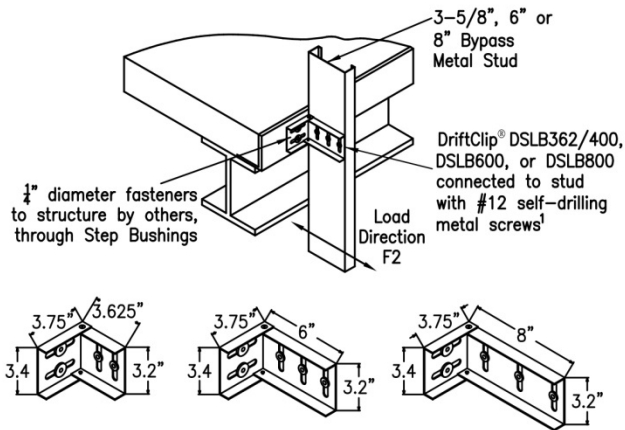

Figure 6 – DriftClip® DSLB362/400, DSLB600 and DSLB800

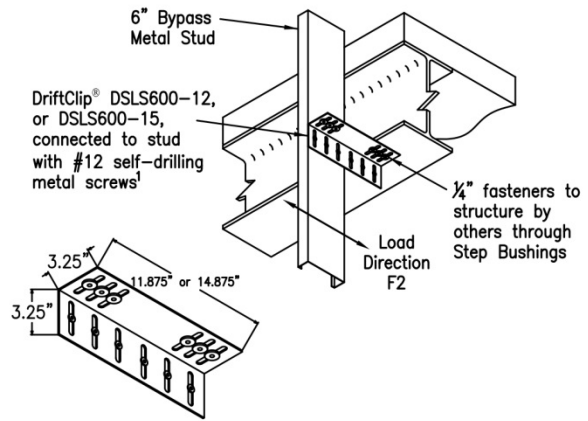

Figure 7 – DriftClip® DSLS600-12 and DSLS600-15

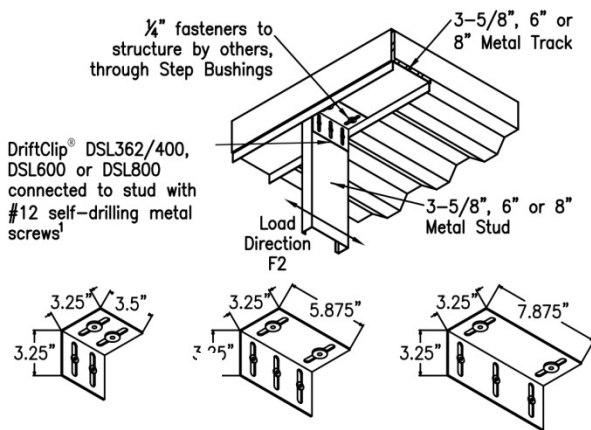

Figure 8 – DriftClip® DSL362/400, DSL600 and DSL800

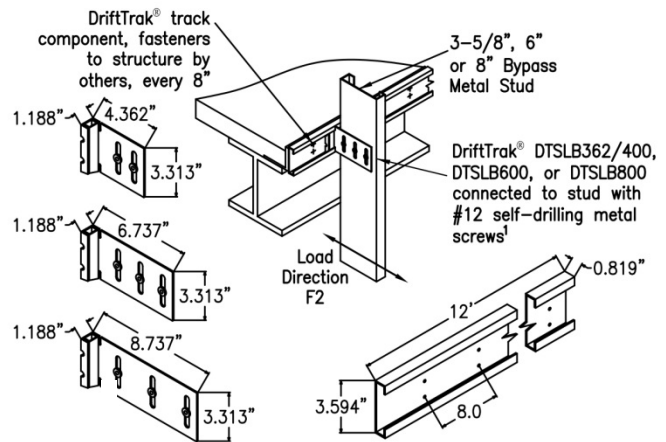

Figure 9 – DriftTrak® DTSLB362/400, DTSLB600 and DTSLB800

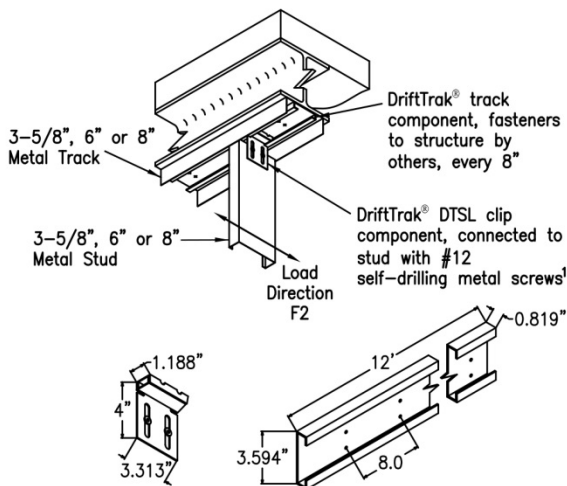

Figure 10 – DriftTrak® DTSL

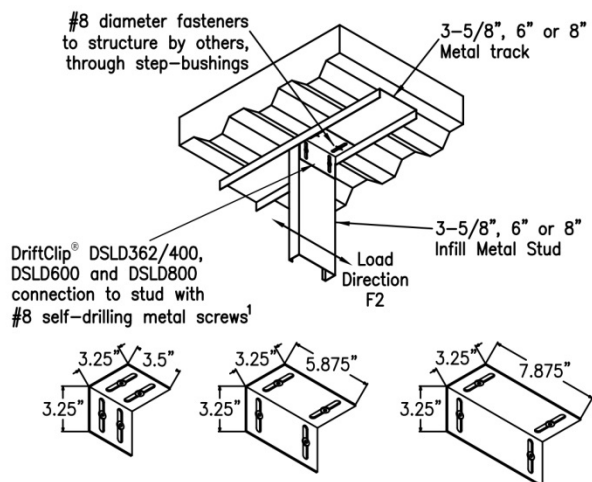

Figure 11 – DriftClip® DSLD362/400, DSLD600 and DSLD800

ICC-ES Evaluation Report ESR-2049 CA Supplement w/ DSA and OSHPD

Reissued December 2025

This report is subject to renewal December 2026.

www.icc-es.org | (800) 423-6587 | (562) 699-0543

A Subsidiary of the International Code Council®

DIVISION: 05 00 00—METALS
Section: 05 05 23—Metal Fastenings
Section: 05 40 00—Cold-Formed Metal Framing

DIVISION: 09 00 00—FINISHES
Section: 09 22 16.13—Non-Structural Metal Stud Framing

REPORT HOLDER:

THE STEEL NETWORK, INC.

EVALUATION SUBJECT:

VERTICLIP®, DRIFTCLIP® AND DRIFTTRAK® EXTERIOR CURTAIN WALL AND INTERIOR TOP-OF-WALL STEEL STUD CONNECTORS

1.0 REPORT PURPOSE AND SCOPE

Purpose:

The purpose of this evaluation report supplement is to indicate that The Steel Network, Inc., VertiClip®, DriftClip® and DriftTrak® exterior curtain wall and interior top-of-wall steel stud connectors, described in ICC-ES evaluation report [ESR-2049](#), have also been evaluated for compliance with the code noted below.

Applicable code edition:

- 2019 California Building Code (CBC)

For evaluation of applicable chapters adopted by the California Office of Statewide Health Planning and Development (OSHPD) AKA: California Department of Health Care Access and Information (HCAI) and the Division of State Architect (DSA), see Sections 2.1.1 and 2.1.2 below.

2.0 CONCLUSIONS

2.1 CBC

The Steel Network, Inc., VertiClip®, DriftClip® and DriftTrak® Connectors, described in Sections 2.0 through 7.0 of the evaluation report [ESR-2049](#), comply with CBC Chapter 22, provided the design and installation are in accordance with the 2018 *International Building Code*® provisions noted in the evaluation report and the additional requirements of CBC Chapters 16, 17 and 22, as applicable.

2.1.1 OSHPD:

The Steel Network, Inc., VertiClip®, DriftClip® and DriftTrak® Connectors, described in Sections 2.0 through 7.0 of the evaluation report [ESR-2049](#), comply with CBC amended Chapters 16, 17 and 22 and Chapters 16A, 17A and 22A, provided the design and installation are in accordance with the 2018 *International Building Code*® provisions noted in the evaluation report and the additional requirements in Sections 2.1.1.1 and 2.1.1.2 of this supplement.

2.1.1.1 Conditions of Use:

1. All loads applied shall be determined by a registered structural engineer and shall comply with applicable loads from CBC Chapter 16 and its amendments, and Chapter 16A.
2. Design and installation shall comply with requirements of OSHPD Preapproved Details (OPD) OPD-0001-13, as applicable.

2.1.1.2 Special Inspection Requirements:

1. Periodic special inspection is required, in accordance with Section 1705A.12.5 of CBC [OSHPD 1 & 4].

2.1.2 DSA:

The Steel Network, Inc., VertiClip®, DriftClip® and DriftTrak® Connectors, described in Sections 2.0 through 7.0 of the evaluation report [ESR-2049](#), comply with CBC amended Chapter 16, and Chapters 17A, 22 and 22A, provided the design and installation are in accordance with the 2018 International Building Code® provisions noted in the evaluation report and the additional requirements in Sections 2.1.2.1 and 2.1.2.2 of this supplement.

2.1.2.1 Conditions of Use:

1. All loads applied shall be determined by a registered structural engineer and shall comply with applicable loads from CBC Chapter 16 and its amendments, and Chapter 16A.
2. Design and installation shall comply with requirements of DSA Interpretation of Regulations (IR) DSA IR 24-2, as applicable.

2.1.2.2 Special Inspection Requirements:

1. Periodic special inspection is required, in accordance with Section 1705A.12.5 of CBC [DSA-SS/CC].

This supplement expires concurrently with the evaluation report, reissued December 2025.

DIVISION: 05 00 00—METALS**Section: 05 05 23—Metal Fastenings****Section: 05 40 00—Cold-Formed Metal Framing****DIVISION: 09 00 00—FINISHES****Section: 09 22 16.13—Non-Structural Metal Stud Framing****REPORT HOLDER:**

THE STEEL NETWORK, INC.

EVALUATION SUBJECT:**VERTICLIP®, DRIFTCLIP® AND DRIFTTRAK® EXTERIOR CURTAIN WALL AND INTERIOR TOP-OF-WALL STEEL STUD CONNECTORS****1.0 REPORT PURPOSE AND SCOPE****Purpose:**

The purpose of this evaluation report supplement is to indicate that the VertiClip®, DriftClip® and DriftTrak® exterior curtain wall and interior top-of-wall steel stud connectors, described in ICC-ES evaluation report [ESR-2049](#), have also been evaluated for compliance with the code noted below.

Applicable code edition:2020 *Florida Building Code—Building***2.0 CONCLUSIONS**

The VertiClip®, DriftClip® and DriftTrak® connectors, described in Sections 2.0 through 7.0 of the evaluation report [ESR-2049](#), comply with the *Florida Building Code—Building*. The design requirements shall be determined in accordance with the *Florida Building Code—Building*. The installation requirements noted in ICC-ES evaluation report [ESR-2049](#) for the 2018 *International Building Code*® meet the requirements of the *Florida Building Code—Building*.

Use of the VertiClip®, DriftClip® and DriftTrak® Connectors has also been found to be in compliance with the High-Velocity Hurricane Zone provisions of the *Florida Building Code—Building* with the following condition:

- a) For connections subject to uplift, the connection must be designed for no less than 700 pounds (3114 N).

For products falling under Florida Rule 61G20-3, verification that the report holder's quality-assurance program is audited by a quality-assurance entity approved by the Florida Building Commission for the type of inspections being conducted is the responsibility of an approved validation entity (or the code official, when the report holder does not possess an approval by the Commission).

This supplement expires concurrently with the evaluation report, reissued December 2025.