

SYSTEM NO. HW-D-0625

ANSI/UL2079
Assembly Ratings - 2 Hr

Nominal Joint Width - See Chart, Section 3
Class II or III Movement Capabilities - See Chart, Section 3

L Rating at Ambient - Less Than 1 CFM/Lin Ft
L Rating at 400°F - Less Than 1 CFM/Lin Ft

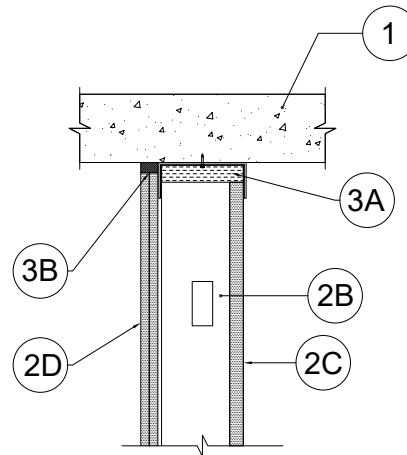

1. **Floor Assembly** — Min 4-1/2 in. (114 mm) thick steel reinforced lightweight or normal weight (100-150 pcf or 1600-2400 kg/m³) structural concrete. Floor may also be constructed of any min 6 in. thick UL Classified hollow-core Precast Concrete Units*.

See **Precast Concrete Units** (CFTV) category in the Fire Resistance Directory for names manufacturers.

The hourly fire rating of the floor assembly shall be equal or greater than the hourly fire rating of the wall assembly.

2. **Shaft Wall Assembly** — The 2 hr fire rated gypsum board/stud wall assembly shall be constructed of the materials and in the manner described in the individual U400 or V400 Series Wall and Partition Design in the UL Fire Resistance Directory and shall include the following construction features:
 - A. **Steel Floor and Ceiling Runners** — Floor runner U-shaped, sized to accommodate steel studs (Item 2B), fabricated from min 24 ga galv steel. Runners attached to floor with steel fasteners located not greater than 2 in. from ends and not greater than 24 in OC. The ceiling runners are provided with a fill, void or cavity material and are described in Item 3.
 - B. **Studs** — "C-T", "I" or "C-H" shaped steel studs to be min 2 1/2 in. (64 mm) wide and formed of min 24 ga galv steel. Studs cut 1 to 1-1/4 in (25 to 32 mm) less in length than assembly height with bottom nesting in and secured to floor runner. Steel studs secured to slotted leg of ceiling runner on finished side with No. 8 by 1/2 (13 mm) long wafer head steel screws at mid-height of exposed slot. Studs spaced max 24 in. (610 mm) OC.
 - C. **Gypsum Board*** — 1 in. (25 mm) thick by max 24 in. (610 mm) wide gypsum board liner panels. Panels cut max 1- 1/4 in. 32 mm) less in length than floor to ceiling height. Vertical edges inserted into "T" shaped section of "C-T" studs, into holding tabs of "I" studs or into "H"-shaped section of "C-H" studs.
 - D. **Gypsum Board*** — Gypsum board 1/2 or 5/8 in. (13 or 16 mm) thick, applied on finished side of wall as specified in the individual Wall and Partition Design. The boards cut a max 1-1/4 in. (32 mm) less in length than the floor to ceiling height. The screws attaching the gypsum board layer(s) to the "C-T", "I" or "C-H" studs shall be located between 3 and 4 in. (76 -102 mm) down from ceiling surface.

The hourly fire rating of the joint system is equal to the hourly fire rating of the wall.

SYSTEM NO. HW-D-0625

ANSI/UL2079
Assembly Ratings - 2 Hr

Nominal Joint Width - See Chart, Section 3
Class II or III Movement Capabilities - See Chart, Section 3

L Rating at Ambient - Less Than 1 CFM/Lin Ft
L Rating at 400°F - Less Than 1 CFM/Lin Ft

3. **Joint System** — Max separation bottom of floor and top of gypsum board (at time of installation) is 3/8" in. (6 mm) or 3/4 in. The joint system is designed to accommodate a max 100 or 80 percent compression and 100 or 33 percent extension from its installed width. When B1 is used the nominal gap is 3/8 (6 mm) and the movement is 100% extension and compression. When 3B2, 3B4 or 3C is used to fill in the nominal gap, the maximum installed joint width is 3/4 in. (19 mm) and the movement is 80% compression and 33% extension. When 3B3 is used to fill nominal gap, the maximum installed width is 1/2 in. (13mm) and movement is 75% compression and 25% extension. When 3B is used to fill in the nominal gap, the maximum installed joint width is 1/2 in. (13 mm) and the movement is 50% compression and 0% extension. When 3B5 is used to fill in the nominal gap, the maximum installed joint width is 3/8 in. (9.5 mm) and the movement is 50% compression only. When 3B6 is used the joint will accommodate 100% compression/extension for nominal 1/4 in. (6mm) gaps or compression only for 1/2 in. (12mm) gaps. When 3B7 is used the joint will accommodate 100 % compression/extension for nominal 1/2 in. (12 mm) gaps or compression only for nominal 1 in.

A. **Forming Material*** — Min 2 in. (51 mm) thick min 4 pcf (64 kg/m³) mineral wool batt insulation cut to friction fit 33% compression in width and installed into ceiling runner between leg of track and gypsum liner board.

| Item | Product | Max Gap | Movement |
|------|--|---------|--------------------|
| 3B | FIRE BEAD (CEMCO, MARINO/WARE, TRIM-TEX) | 1/2" | 50% Comp 0% Ext |
| 3B1 | FAS J-Track (CEMCO, MARINO/WARE) | 3/8" | 100% Comp & Ext |
| 3B2 | HOTROD Type-X (CEMCO, MARINO/WARE) | 3/4" | 80% Comp 33% Ext |
| 3B3 | HOTROD Type-X (CEMCO, MARINO/WARE) | 1/2" | 75% Comp 25% Ext |
| 3B4 | HOTROD Type-XL (CEMCO, MARINO/WARE, TRIM-TEX) | 3/4" | 80% Comp 33% Ext |
| 3B5 | Super Seal-X (CEMCO, MARINO/WARE, TRIM-TEX) | 3/8" | 50% Comp 0% Ext |
| 3B6 | Fire Gasket 0.5 (CEMCO, MARINO/WARE, TRIM-TEX) | 1/4" | 100% Comp 100% Ext |
| 3B6 | Fire Gasket 0.5 (CEMCO, MARINO/WARE, TRIM-TEX) | 1/2" | 100% Comp 0% Ext |
| 3B7 | Fire Gasket 1 (CEMCO, MARINO/WARE, TRIM-TEX) | 1/2" | 100% Comp 100% Ext |
| 3B7 | Fire Gasket 1 (CEMCO, MARINO/WARE, TRIM-TEX) | 1" | 100% Comp 0% Ext |
| 3C | 7/8" "Denver Foam" open cell backer rod with layer of tape and joint compound (optional) | 3/4" | 80% Comp 33% Ext |

C. **Fill, Void or Cavity Material*** — (Optional, Not Shown) — For use with items 3B1, Non 7/8 in. (22 mm) open cell backer rod, trade name "Denver Foam" can be placed in the joint above the top edge of the drywall between the concrete slab. A layer of tape and joint compound shall then be applied over the open cell backer rod.

D. **Fill, Void or Cavity Material* — Sealant** — (Optional, Not Shown) — Where HOTROD (Item 3B2, 3B3 or 3B4) is not installed, sealant may be used to seal any gaps at end joints between ceiling runners to maintain L Ratings.
UNITED STATES GYPSUM CO — Type AS

*** Indicates such products shall bear the UL or cUL Certification Mark for jurisdictions employing the UL or cUL Certification (such as Canada), respectively.**

The appearance of a company's name or product in this database does not in itself assure that products so identified have been manufactured under UL's Follow-Up Service. Only those products bearing the UL Mark should be considered to be Certified and covered under UL's Follow-Up Service. Always look for the Mark on the product.

UL permits the reproduction of the material contained in the Online Certification Directory subject to the following conditions: 1. The Guide Information, Assemblies, Constructions, Designs, Systems, and/or Certifications (files) must be presented in their entirety and in a non-misleading manner, without any manipulation of the data (or drawings). 2. The statement "Reprinted from the Online Certifications Directory with permission from UL" must appear adjacent to the extracted material. In addition, the reprinted material must include a copyright notice in the following format: "© 2021 UL LLC"



Reproduced Courtesy of Underwriters Laboratories, Inc.
Created or Revised: July 15, 2021

CEMCO® | P: (800) 775-2362 | F: (626) 330-7598 | www.cemcosteel.com

Page 2 of 2



HW-D-0625