



Thank you for giving UL the opportunity to partner with you.

Please note, Follow-Up Procedure Revisions or Report Revisions do not include Authorization Pages, Indices, Section General, and/or Appendices unless revisions were required or requested.

Should you have any questions, after reviewing the material, or need to report any inaccuracies, please reach out to your UL representative or find UL contact details for your local Customer Service Department at <https://www.ul.com/about/locations>.

Please find attached the related material

For your convenience, the below describes the related updates:

| |
|-----------------------------------|
| R25033-20210531-Report-Evaluation |
|-----------------------------------|

This material is provided on behalf of UL LLC (UL) or any authorized licensee of UL.

Times change, Trust Remains™

UL Evaluation Report

UL ER25033-01

Issued: May 31, 2021
Revised: January 16, 2023

Visit UL's [Product iQ database](#) for current status of Report.

UL Category Code: ULFE

CSI MasterFormat®

DIVISION: 05 00 00 – METALS
Sub-level 2: 05 40 00 – Cold-Formed Metal Framing

DIVISION: 07 00 00 – THERMAL AND MOISTURE PROTECTION
Sub-level 2: 07 80 00 – Fire and Smoke Protection
Sub-level 3: 07 84 00 – Firestopping
Sub-level 4: 07 84 43 – Joint Firestopping

DIVISION: 09 00 00 – FINISHES
Sub-level 2: 09 22 16.13 – Non-Structural Metal Stud Framing

COMPANY:

CEMCO, LLC
13191 CROSSROADS PKY N, SUITE 325
CITY OF INDUSTRY, CA, 91746
<https://cemcosteel.com/>

1. SUBJECT:

Expansion Joint Systems consisting of one or more of the following:

| Component Type | Product Designation(s) |
|---|--|
| Deflection Track | FAS Track 1000, Fire Rated J-Track |
| Deflection Drift Angle | DDA, DDA-1 |
| Galvanized steel or vinyl profile angle | Fire Bead, Fire Gasket 0.5, Fire Gasket 1, Fire Gasket 1.5, FAS 093X, FAS 093X-V |
| Steel strap | FAS Strap, FAS RBR Strap |
| Foam block | HOTROD Type X (which may be suffixed by “1” or “2”), HOTROD Type XL |



2. SCOPE OF EVALUATION

- 2018 and 2015 International Building Code (IBC)
- 2019 California Building Code (CBC)
- 2019 California Residential Code (CRC)
- 2020 City of Los Angeles Building Code (LABC)
- 2019 Chicago Building Code
- 2020 Florida Building Code – Residential
- 2022 New York City Building Code

The individual chapters of the California Building Code, City of Los Angeles Building Code, and Chicago Building Code (as noted above) have adopted the requirements of the 2018 International Building Code (IBC) applicable to these products, except as noted in this report. Refer to SECTION 7 - Conditions of Use for details.

The products were evaluated for the following properties:

- Structural
- Fire resistance

3. REFERENCED DOCUMENTS

- ANSI/UL 2079, Tests for Fire Resistance of Building Joint Systems
- ICC-ES Acceptance Criteria for Cold-Formed Steel Framing Members (AC46)
- ICC-ES Acceptance Criteria for Quality Documentation (AC10)

4. USES

CEMCO's expansion joint systems are for use in interior fire-resistance-rated, non-load bearing, light-gage steel framed wall assemblies. The components are used to form a fire-resistive expansion joint at the top of the wall which allows vertical movement of the building resulting from loads created by wind, seismic activity, thermal expansion or shrinkage, and/or other sources. The expansion joint systems are installed to provide positive attachment of wall studs to the top track in fire-resistance-rated joints to accommodate vertical movement in compliance with 2018 and 2015 IBC Section 715.2, and/or Section 715.2 of the 2022 New York City Building Code..

5. PRODUCT DESCRIPTION

5.1 General:

FAS Track 1000 deflection tracks are formed from minimum 0.033 in. thick (20 gauge) galvanized steel. The U shaped tracks are nominal 2-1/2 in. to 8 in. wide with nominal 3-1/4 in. legs and 1-1/2 in. slots. Two nominal 1/2 in. wide intumescent strips are adhered to the web. The 33 and 43 mil thick tracks are formed from steel conforming with either ASTM A1003 or ASTM A652. The 33 mil thick tracks have a G40 or greater galvanized coating and the 43 mil thick tracks have a G60 or greater galvanized coating. The 54

and 68 mil tracks are formed from ASTM A1003 ST50H complaint steel or ASTM A653 SS, Grade 50 steel. The 54 mil and 68 mil tracks have a G60 or greater galvanized coating. Refer to Ill. 1 for details.

Fire Rated J-Track deflection tracks are formed from 33 mil (20 gauge) galvanized steel. The J-shaped tracks are nominal 2-1/2 and 4 to 6 in widths, with 2-1/2 in and 1-1/2 in. legs. A nominal 1/2 in. wide intumescent strip is adhered onto the web directly above the 1-1/2 in. leg. The deflection tracks are formed from ASTM A1003 ST33H and ASTM A652 SS, Grade 33 compliant steel with a minimum G40 galvanized coating. Refer to Ill. 2 for details.

DDA Deflection Drift Angle is a nominal 3/4 in. by 2-1/2 in. angle formed from minimum 25 gauge galvanized steel and provided with a nominal 5/8 in. wide intumescent strip attached to the 2-1/2 in. leg.

DDA-1 Deflection Drift Angle is nominal 5/8 in. by 1-1/4 inch formed of minimum 25 gauge galvanized steel and provided with a nominal 5/16 in. wide intumescent strip attached to the 1-1/4 in. leg

Types DDA and DDA-1 angles are formed from 18 mil hot-dipped galvanized steel complying with ASTM A1003 ST33H or ASTM A653 SS, Grade 33. Refer to Ills. 3 and 3A for details.

Fire Bead is nominal 1/2 in. by 1-1/8 in. angle formed of vinyl with a nominal 5/16 in. wide intumescent strip attached to the flat horizontal piece of vinyl behind the 1/2 in. long seal material. Refer to Ill. 4 for details.

Fire Gasket 0.5 is nominal 1-1/8 in. wide along the leg and a 1/4 in. bubble gasket profile formed of vinyl. The profile incorporates a 3mm x 1/4 in. intumescent tape and a 1/2 in. wide strip of double sided adhesive tape affixed along the inside of the 1-1/8 in. leg. Refer to Ill. 5 for details.

Fire Gasket 1 is nominal 1-5/8 in. wide along the leg and a 3/8 in. bubble gasket profile formed of vinyl. The profile incorporates both a 5/8 in. wide intumescent tape and a 1/2 in. wide strip of double sided adhesive tape affixed along the inside of the 1-5/8 in. leg. Refer to Ill. 6 for details.

Fire Gasket 1.5 is nominal 2 in. wide along the leg and a 3/8 in. bubble gasket profile formed of vinyl. The profile incorporates both a 1 in. wide intumescent tape and a 1/2 in. wide strip of double sided adhesive tape affixed along the inside of the 2 in. leg. Refer to Ill. 6 for details.

FAS093X is nominal 2 in. wide angle formed of 25 gauge galvanized steel and provided with a nominal 5/16 in. wide intumescent strip attached to the trough. Refer to Ill. 7 for details.

FAS-093X-V is nominal 2 in. wide angle with a nominal 5/16 in. wide intumescent strip attached to one or both sides of the trough. Refer to Ill. 8 for details.

FAS STRAP is nominal 10-1/2 in. wide steel strap with roll formed reinforcement ridges and two strips of 1/2 in. wide intumescent tape on the edges. The strap is formed of 33 mil thick (20 gauge) galvanized steel. Refer to Ill. 9 for details.

FAS RBR STRAP is a nominal 6 in. wide steel strap with one strip of 5/8 in. wide intumescent tape along one edge of the steel strap. The strap is formed of 33 mil thick (20 gauge) galvanized steel. Refer to Ill. 10 for details.

Hot Rod Type X1 is nominal 1/2 in. wide by 1 in. tall foam blocks formed of open cell polyurethane backer rod and provided with a nominal 5/16 in. wide intumescent strip attached to the face of the foam block adjacent to the corner. Type X1 is for use in 1 hour rated walls. Refer to Ill. 11 for details.

Hot Rod Type X2 is nominal 1 in. wide by 1 in. tall foam blocks formed of open cell polyurethane backer rod and provided with a nominal 5/16 in. wide intumescent strip attached to the face of the foam block adjacent to the corner. Type X2 is for use in 2 hour rated walls. Refer to Ill. 11 for details.

Hot Rod Type XL is nominal 1/2 in. wide by 3/4 in. foam tall strip formed of soft cell polyurethane backer rod and provided with a nominal 5/16 in. wide intumescent strip attached to the bottom side of the 1/2 inch horizontal leg. Refer to Ill. 11A for details.

The following designations may be used when referring to the products covered in this report:

| System Name | FAS 1000 | FAS J | DDA | DDA-1 |
|-----------------------------|---|---|------------|--------------|
| Section Designations | 250FT275-33, 250FT275-43, 250FT275-54, 250FT275-68 362FT275-33, 362FT275-43, 362FT275-54, 362FT275-68 400FT275-33, 400FT275-43, 400FT275-54, 400FT275-68 600FT275-33, 600FT275-43, 600FT275-54, 600FT275-68 800FT275-33, 800FT275-43, 800FT275-54, 800FT275-68 | 250FASJ250-33, 400FASJ250-33, 600FASJ250-33 | 075DDA-18 | 1.5DDA-18 |

6. INSTALLATION

6.1 General:

The deflection track systems are designed for an allowable total vertical movement of 1-1/2 inches (+/- 3/4 inch) for Fire Rated J-Track and 1 inch (+/- 1/2 inch) for FAS Track 1000. The screws must be installed through the center of the slots designed for upward or downward movement, without impairing the movement of the track while not jeopardizing the attachment to the framing member. The fasteners must penetrate the stud by at least a minimum of three threads. The vertical leg of the Deflection Drift Angle must be in contact with the surface of the gypsum board and the horizontal leg must be attached to the adjoining assembly using the fasteners described within the assembly.

6.2 UL Fire-resistance-rated assemblies:

The expansion joint systems described in this report have been evaluated as a component in assemblies rated for fire resistance in accordance with 2018 IBC and/or 2022 New York City Building Code, Section 715.3. Refer to the UL's product iQ™ for File R25033 ([XHHW](#)) for details of the fire-resistance-rated assemblies covered by this report. Fire resistance ratings are only applicable when the assemblies are constructed in accordance with the published designs.

Additionally, the products described in this report may be used in the assemblies described in Table 721.1(2) of the 2018 IBC and/or 2022 New York City Building Code, as applicable.

7. CONDITIONS OF USE

General:

The expansion joint products described in this report comply with, or are suitable alternatives to what is specified in, those codes listed in Section 2 of this report, subject to the following conditions:

7.1 The products must be manufactured, identified, and installed in accordance with this report and published fire-resistance-rated assembly installation methods, the manufacturer's published installation instructions, and the applicable code. If there is a conflict between the manufacturer's published installation instructions and this report, this report governs.

7.2 See UL Product iQ™ for products evaluated for fire resistance in accordance with UL2079, Fill, Void or Cavity Materials, ([XHHW](#)) under file R25033.

7.3 The products described in this report are manufactured by California Expanded Metal Products Co, at the manufacturing locations named below, under the UL LLC Classification and Follow-Up Service Program, which includes inspections in accordance with the quality elements of ICC-ES Acceptance Criteria for Quality Documentation, AC 10.

| Location | Plant ID (if applicable) |
|------------------|--------------------------|
| City of Industry | IF |
| Pittsburg, CA | UF |
| Fort Worth, TX | FF |

Additionally, types FAS Track 1000, Fire rated J-Track, FAS Strap, and FAS RBR Strap may also be manufactured at the following locations:

| Company Name | Location | Plant ID |
|---|----------------------|----------|
| Marino/Ware, Div. of Ware Industries Inc. | South Plainfield, NJ | #10 |
| Marino/Ware, Div. of Ware Industries Inc. | Griffin, GA | #20 |
| Marino/Ware, Div. of Ware Industries Inc. | East Chicago, IN | #30 |

Types Fire Bead, Fire Gasket 0.5, Fire Gasket 1.0, Fire Gasket 1.5, and Hot Rod Type XL may also be distributed under the Marino/Ware brand.

7.4 Additional Conditions of Use specifically for California Office of Statewide Health Planning and Development (OSHPD) are as follows:

7.4.1 All loads applied to the cold formed steel studs shall be determined by a registered design professional and shall comply with the applicable loads from the 2019 CBC amended sections from Chapters 16 and 16A.

7.4.2 Prescriptive framing is not permitted in accordance with 2019 CBC section 2211A.1.2.

7.4.3 Cold formed steel members shall be designed per the specifications described in AISI S100 in accordance with 2019 CBC, Section 2211.2 and 2211A.2.

7.4.4 The design and installation of non-structural members and connections made from cold formed steel (light frame construction) shall be in accordance with AISI S220 for non-composite assembly design. Where nonstructural members do not qualify for design under AISI S220, the design and installation of non-structural members and connections shall be in accordance with AISI S240 or S100.

7.4.5 When primary and secondary steel members require fire protection, the attachment of secondary members shall be in accordance with the requirements of 2019 CBC Section 705.6.

7.4.6 Special Inspection Requirements:

7.4.6.1 In accordance with 2019 CBC Section 1704.2, Exception 3, special inspection is required for portions of structures designed and constructed in accordance with the cold-formed steel light frame constructions provisions of 2019 CBC Section 2211.1.2.

7.4.6.2 Periodic inspections shall be required in accordance with 2019 CBC Sections 1705A.12.3 and 1705A.12.5.

7.4.7 Design and installation shall be in accordance with 2018 IBC as required by California Office of Statewide Health Planning and Development (OSHPD).

7.5 Additional Conditions of Use specifically for Division of State Architect (DSA) are as follows:

7.5.1 All loads applied to the cold formed steel studs shall be determined by a registered design professional and shall comply with the applicable loads from the 2019 CBC amended sections from Chapters 16 and 16A.

7.5.2 Prescriptive framing is not permitted in accordance with 2019 CBC section 2211A.1.2.

7.5.3 The design and installation of non-structural members and connections made from cold formed steel (light frame construction) shall be in accordance with AISI S220 for non-composite assembly design. Where nonstructural members do not qualify for design under AISI S220, the design and installation of nonstructural members and connections shall be in accordance with AISI S240 or S100.

7.5.4 When primary and secondary steel members require fire protection, the attachment of secondary members shall be in accordance with the requirements of 2019 CBC Section 705.6.

7.5.5 Special Inspection Requirements:

7.5.5.1 Periodic inspections shall be required in accordance with 2019 CBC Sections 1705A.12.3 and 1705A.12.5.

7.5.6 Design and installation shall be in accordance with 2018 IBC as required by the Division of State Architect (DSA).

7.6 Additional Conditions of Use specifically for City of Los Angeles Building Code (LABC) are as follows:

7.6.1 The design, installation and inspection are in accordance with the requirements of LABC Chapters 7, 16, 17, and 22, as applicable.

7.6.2 The design, installation, conditions of use and identification are in accordance with the 2018 IBC as noted in this report.

7.7 Additional Conditions of Use in accordance with the Chicago Building Code:

7.7.1 Special inspections and tests are not required for portions of structures designed and constructed in accordance with the cold-formed steel light frame construction provisions of Section 2211.1.2 or the conventional wood light frame construction provisions of Section 2308.

7.8 Additional Conditions of Use in accordance with the Florida Building Code – Residential:

7.8.1 In accordance with Section R301.2.1.1, the design of cold-formed steel wall, floor and roof framing (including roof framing) shall be in accordance with AISI S230, Standard for Cold-Formed Steel Framing—Prescriptive Method For One- and Two-Family Dwellings.

8. SUPPORTING EVIDENCE

8.1 Manufacturer’s product literature and quality documentation.

8.2 UL Classification reports in accordance with UL2079. See UL Product Certification for File R25033 under Category for Fill, Void or Cavity Materials ([XHHW](#)).

8.3 Reports in accordance with AC46.

9. IDENTIFICATION

The expansion joint products described in this evaluation report are identified by a marking bearing the report holder’s name California Expanded Metal Products Co. (CEMCO), the plant identification, the UL Classification Mark, and the evaluation report number UL ER25033-01. The validity of the evaluation report is contingent upon this identification appearing on the product or UL Classification Mark certificate.

10. USE OF UL EVALUATION REPORT

10.1 The approval of building products, materials or systems is under the responsibility of the applicable authorities having jurisdiction.

10.2 UL Evaluation Reports shall not be used in any manner that implies an endorsement of the product, material or system by UL.

10.3 The current status of this report, as well as a complete directory of UL Evaluation Reports may be found at [UL.com](#) via UL Product iQ™:

[UL Evaluation Reports](#)

TABLE 1 – FAS Track 1000 ALLOWABLE LOADS

| Model No. ¹ | Design Thickness (in.) | Minimum Thickness (in.) | Yield Strength (ksi) | Coating | Web Sizes (in.) | Gap ² (in.) | Allowable Load Per Stud (lb) | Load at 1/8 inch Deflection (lb) |
|------------------------|------------------------|-------------------------|----------------------|---------|-----------------------------|------------------------|------------------------------|----------------------------------|
| 33 | 0.0346 | 0.0329 | 33 | G40 | 2-1/2, 3-5/8, 4, 6, 8 | 5/8 | 125 | 30 |
| 43 | 0.0451 | 0.0428 | 33 | G60 | | | 190 | 50 |
| 54 | 0.0566 | 0.0538 | 50 | G60 | | | 290 | 90 |
| 68 | 0.0713 | 0.0677 | 50 | G60 | | | 385 | 155 |

For SI: 1 inch = 25.4 mm, 1 lbf = 4.448 N, 1 ksi = 6.8948 KPa, 1 lb/ft = 14.5939 N/m

¹ See the last two digits in the section designation table.

² The gap is the maximum distance between the end of the stud and the web of the track

³ Loads are allowable strength loads (ASD). For load and resistance factor design (LRFD), multiply by 1.54.

⁴ Deflection is measured at the edge of the flange away from the web of the deflection track.

ILL. 1 – FAS Track 1000

(A) = 2-1/2", 3-5/8", 4", 6" and 8"
(G) = 20 gauge through 14 gauge

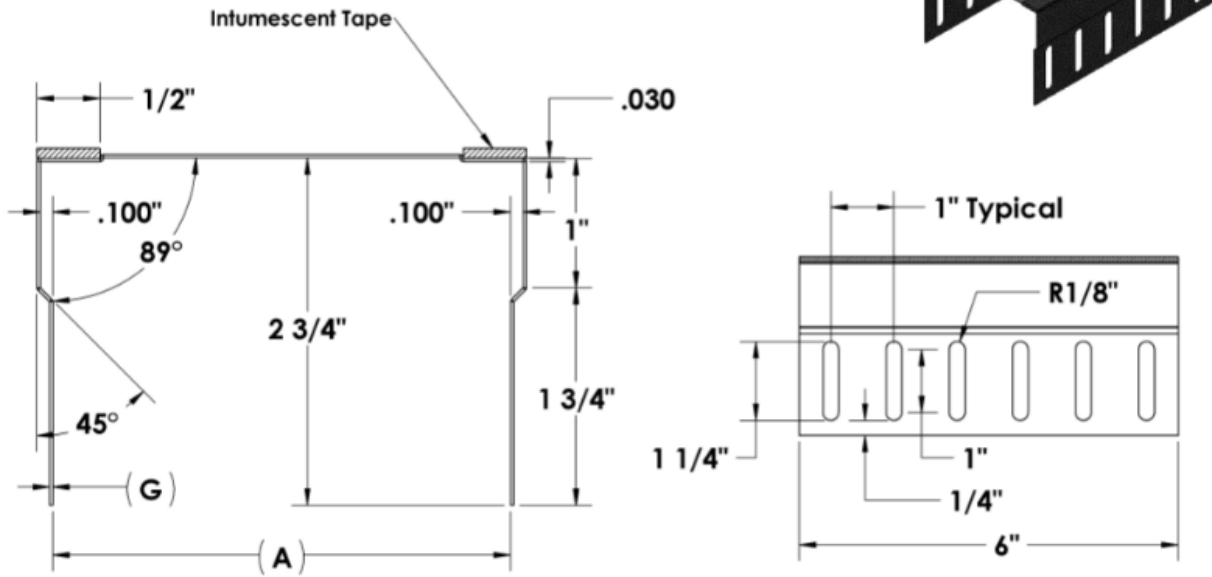

ILL. 2 – Fire Rated J-Track

(A) = 2-1/2", 4" and 6"

20 gauge / 33 mil

Web tolerance +1/8", -0.0"

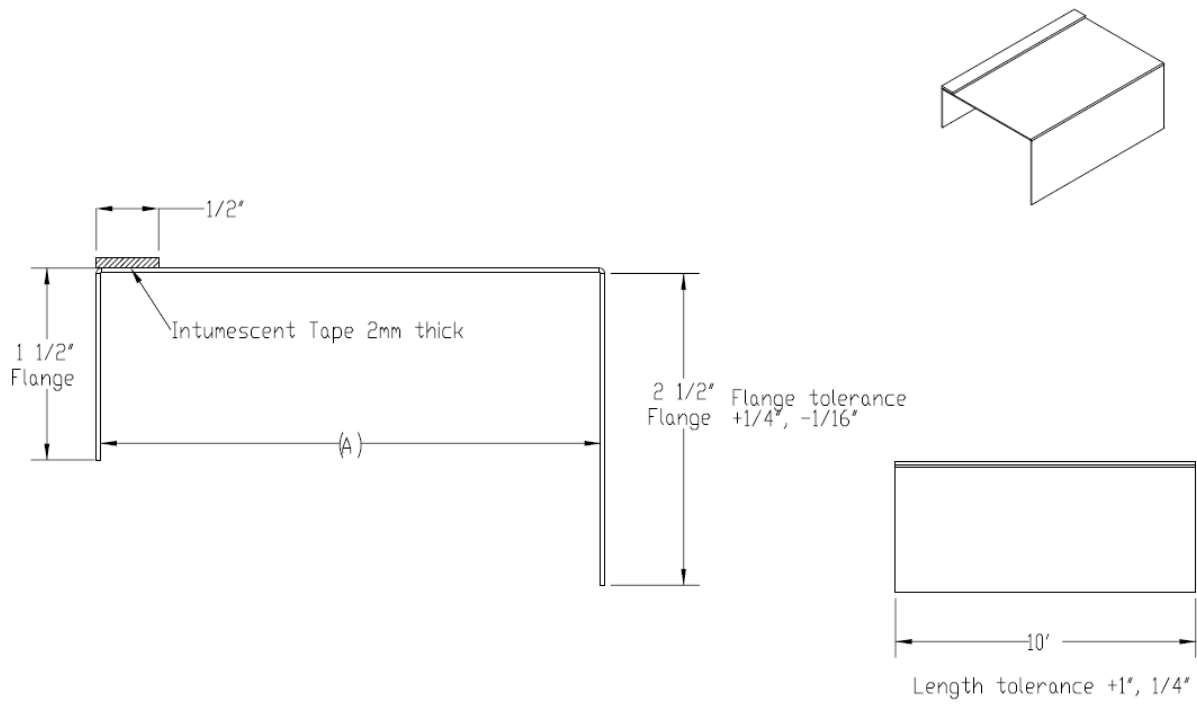

ILL. 3 – Deflection Drift Angle (DDA)

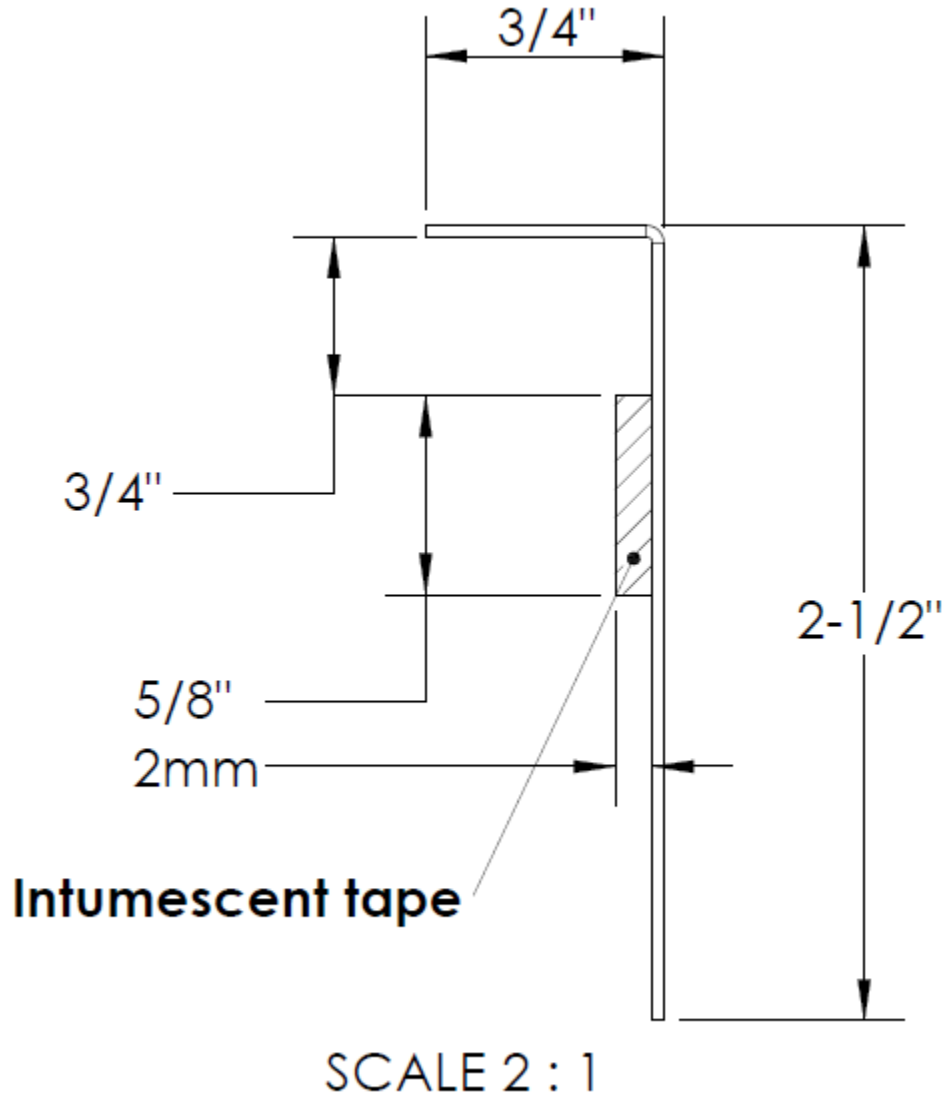

ILL. 3A – Deflection Drift Angle 1 (DDA-1)

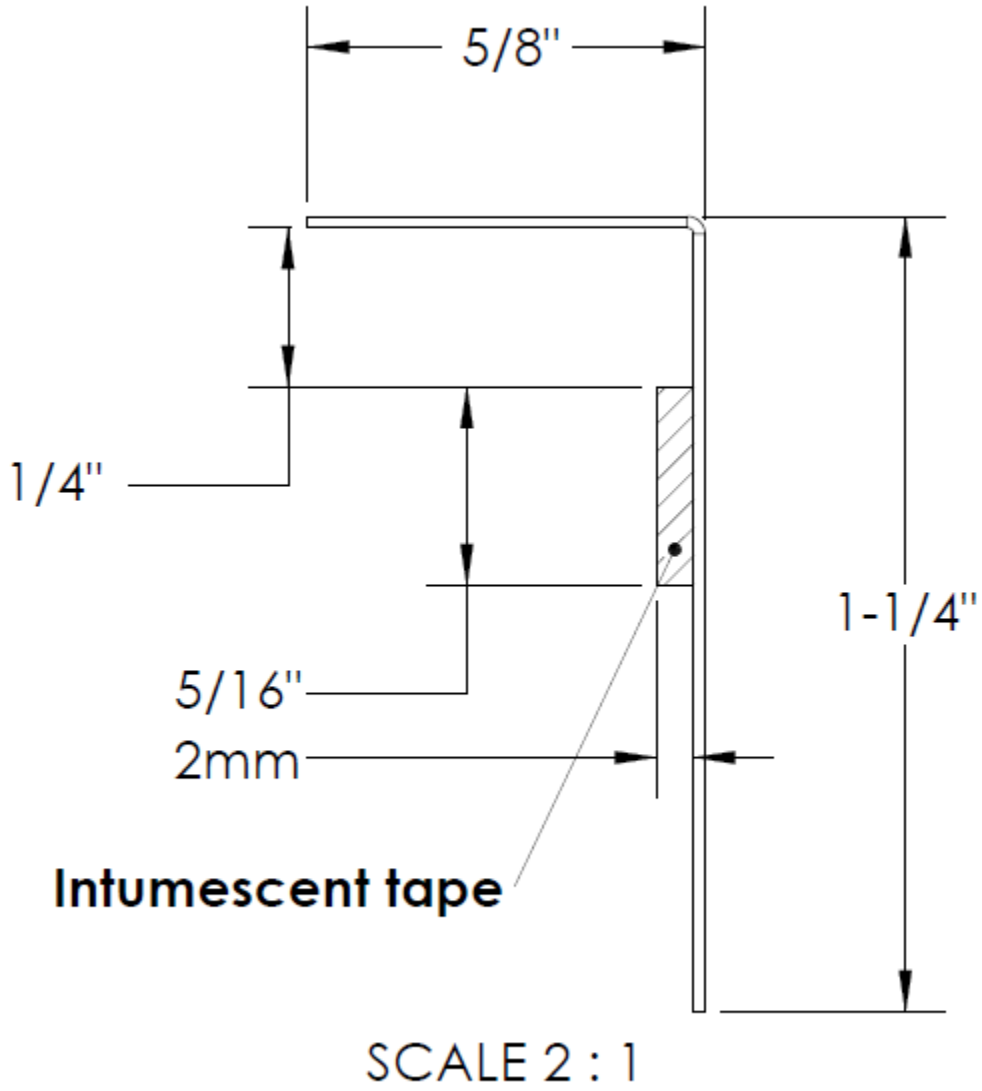

ILL. 4 – Fire Bead

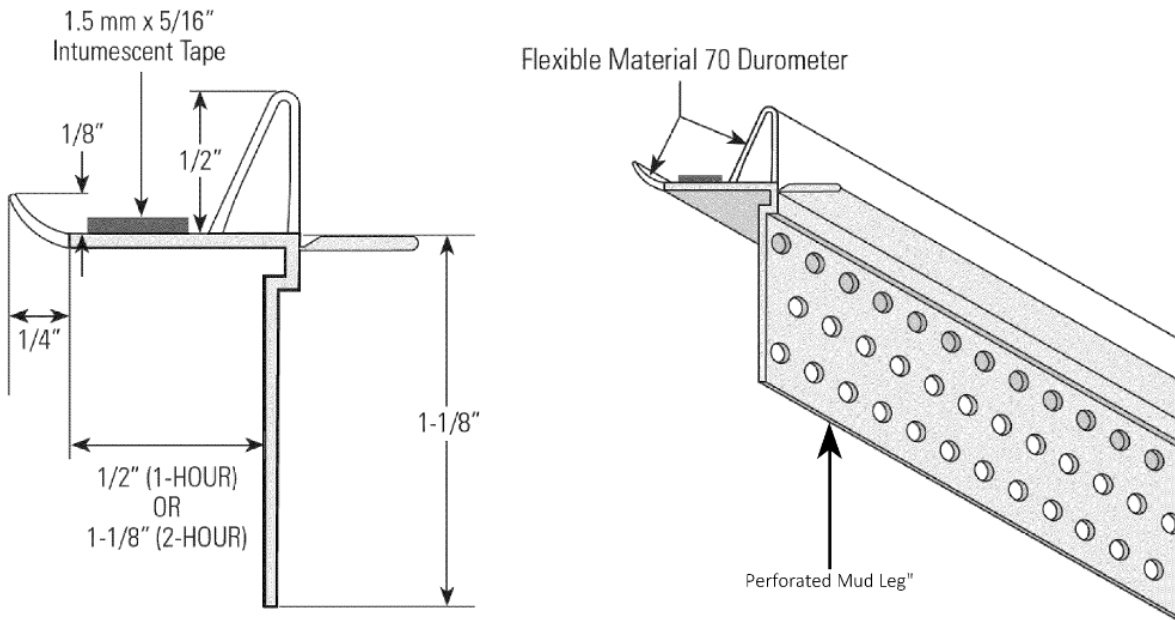

ILL. 5 – Fire Gasket 0.5

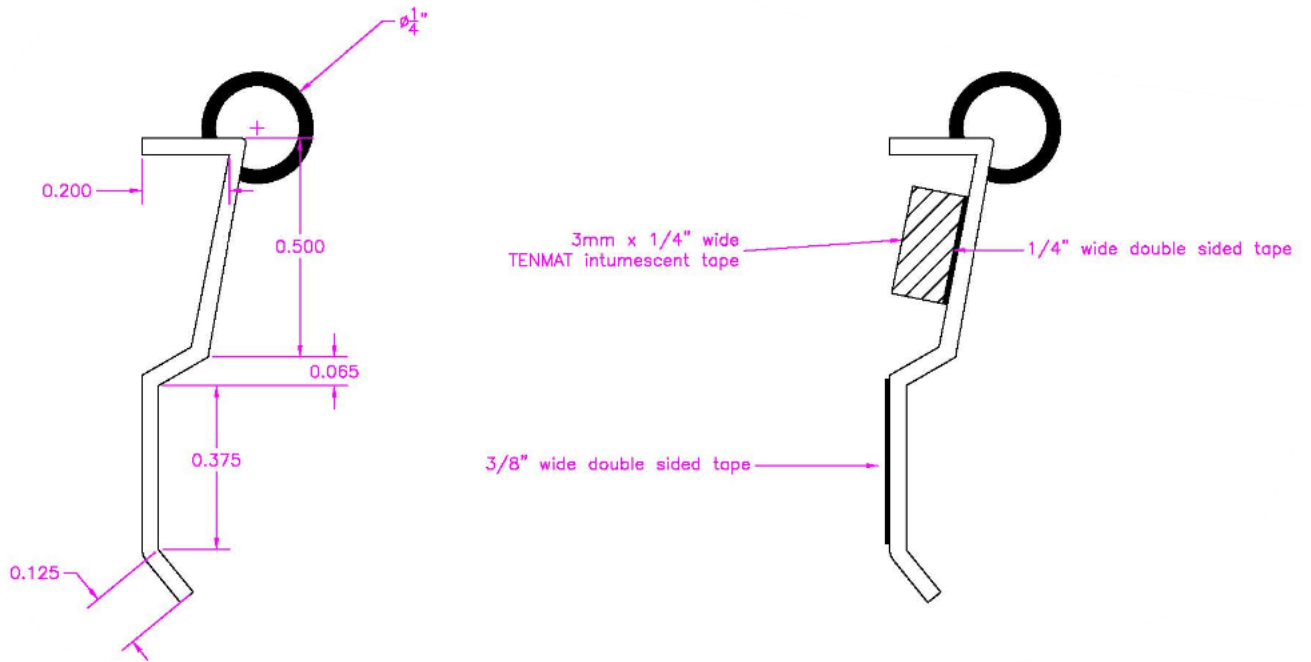

III. 6 – Fire Gasket 1 and Fire Gasket 1.5

FIRE GASKET 1

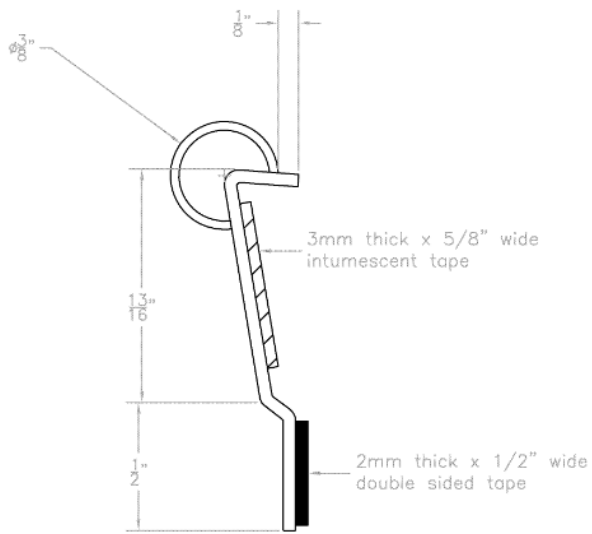

FIRE GASKET 1.5

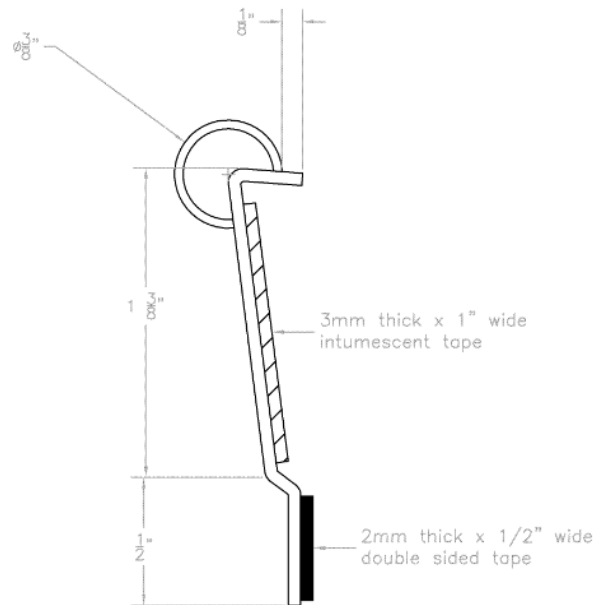

ILL. 7 – FAS 093X

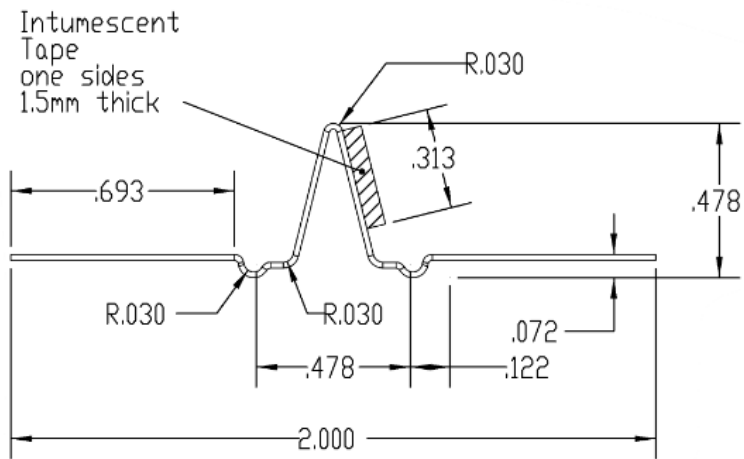
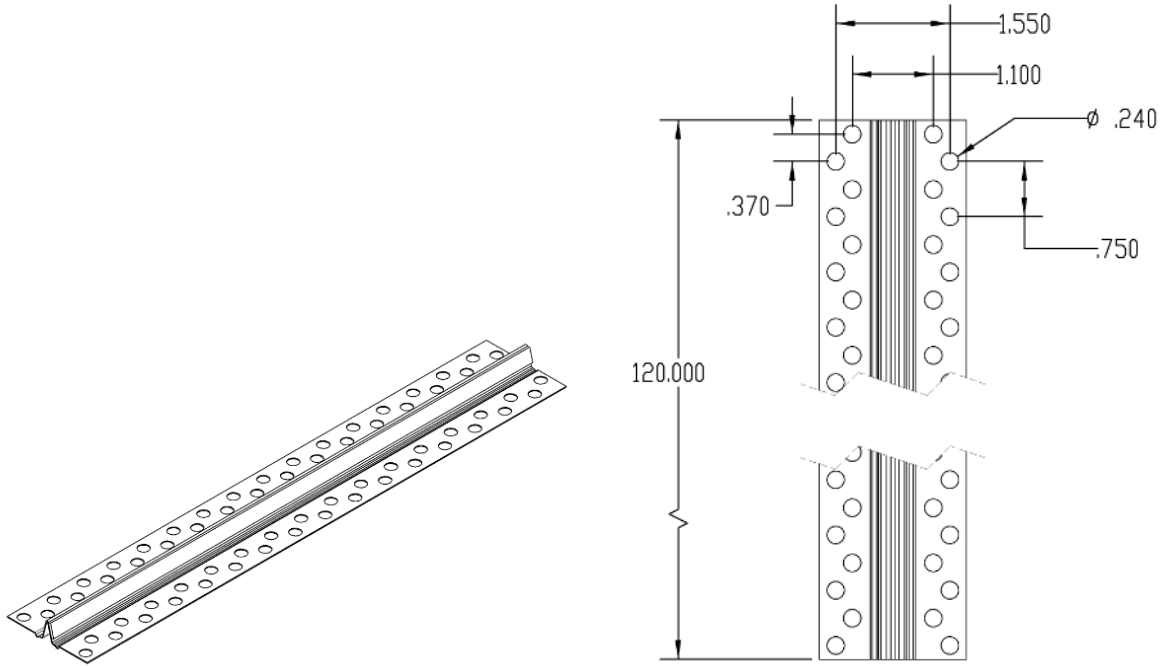

ILL. 8 – FAS 093X-V

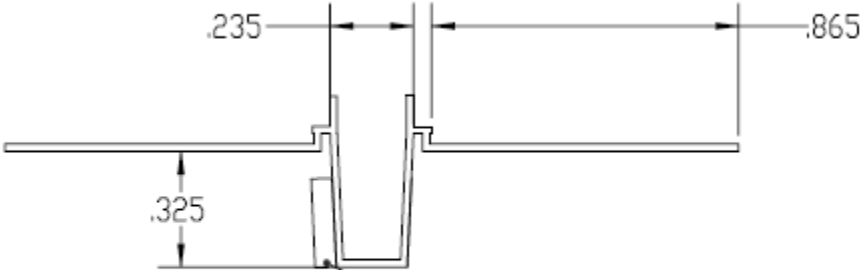
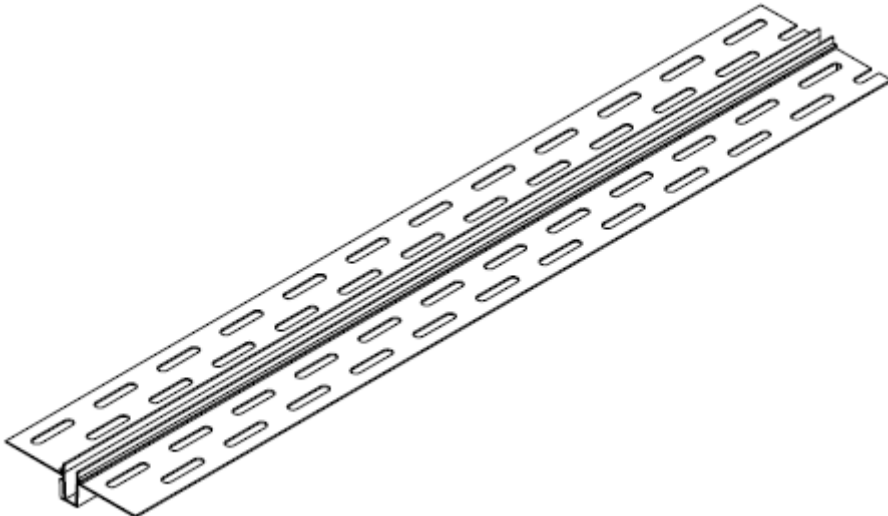

5/16" wide Intumscent Tape each sides
1.5mm thick

ILL. 9 – FAS Strap

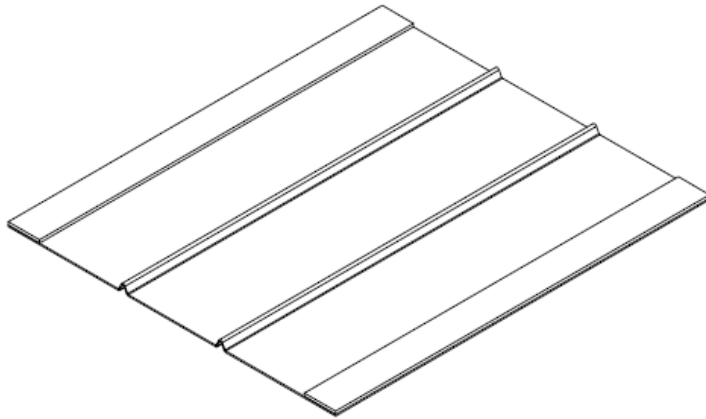
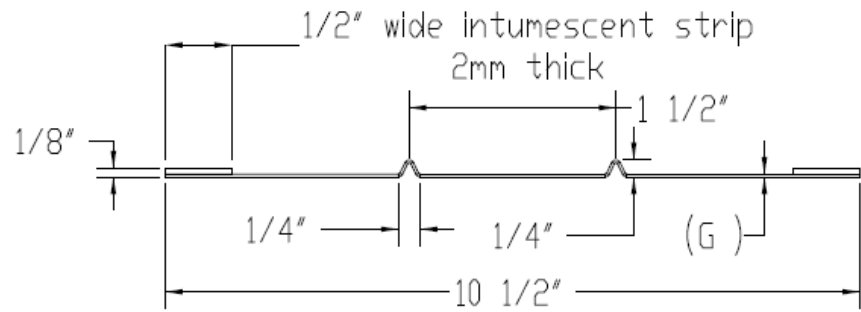

(G)= Base Metal Thickness:
 (0.0329", 0.0428", 0.0538" and 0.0677")
 Design Thickness:
 (0.0346", 0.0451", 0.0566" and 0.0677")
 20 Gauge steel section have a minimum
 G-40 galvanized coating.
 18, 16 and 14 Gauge steel section have
 a minimum G-60 galvanized coating.

ILL. 10 – FAS RBR Strap

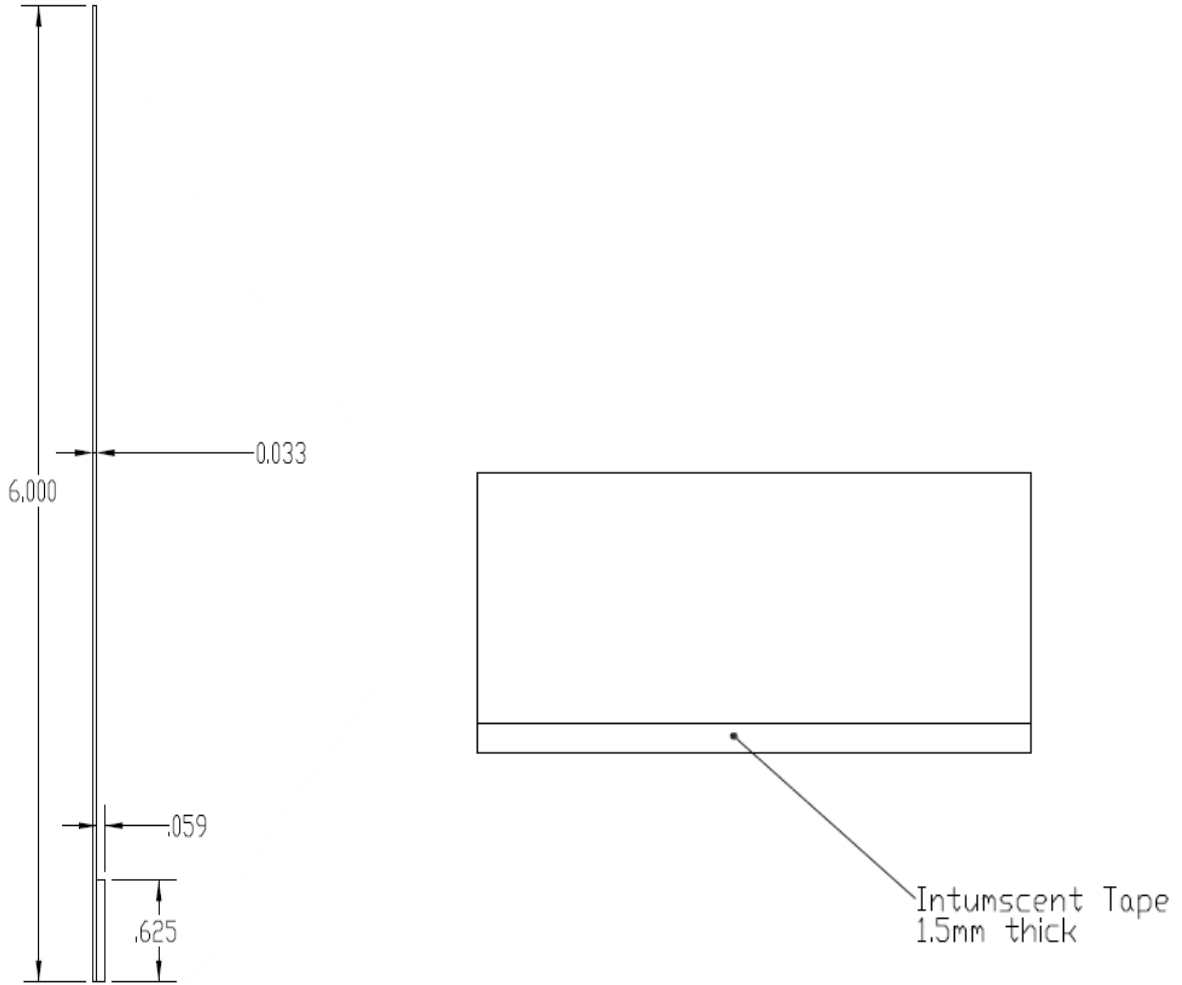

III. 11 – HOTROD Types X1 and X2

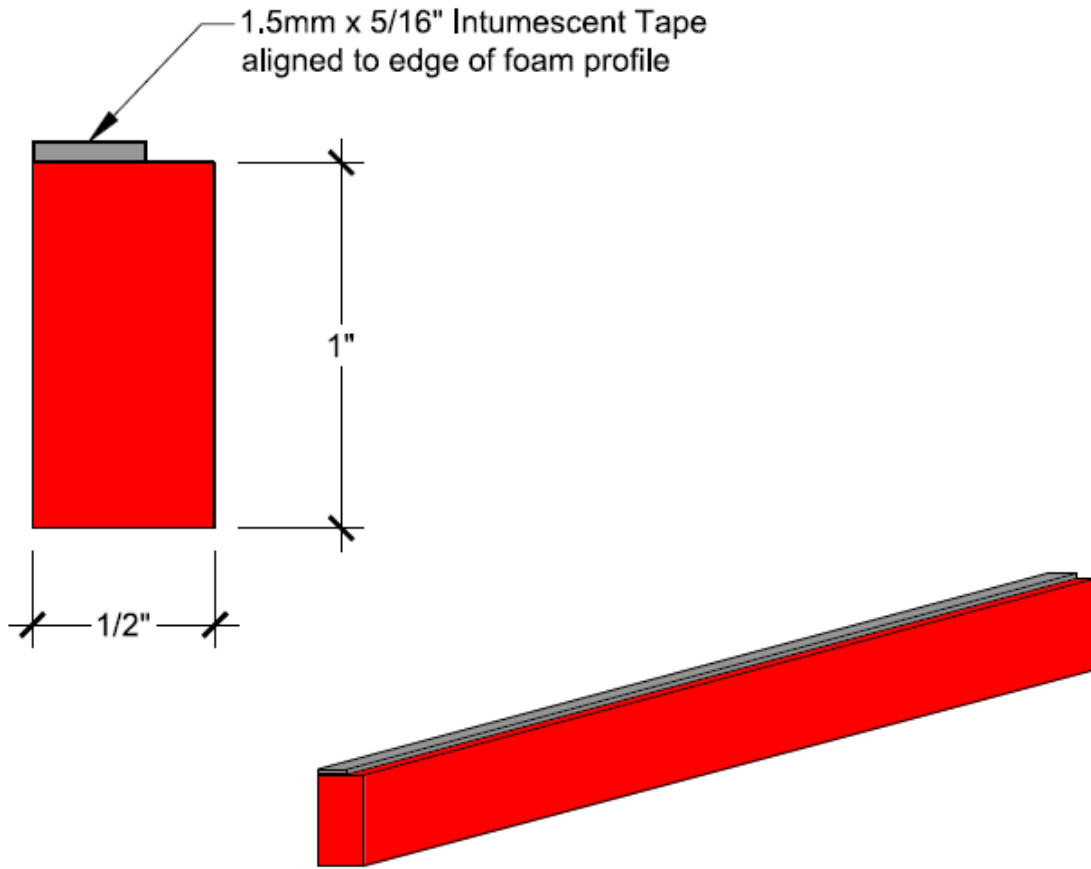

ILL. 11A – HOTROD Type XL

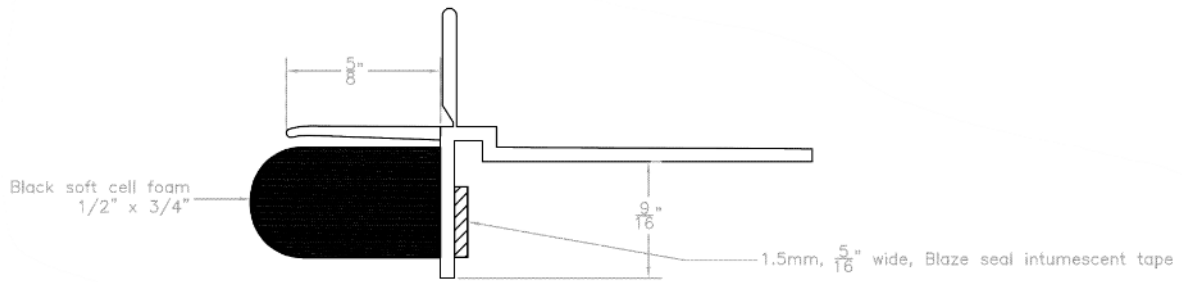
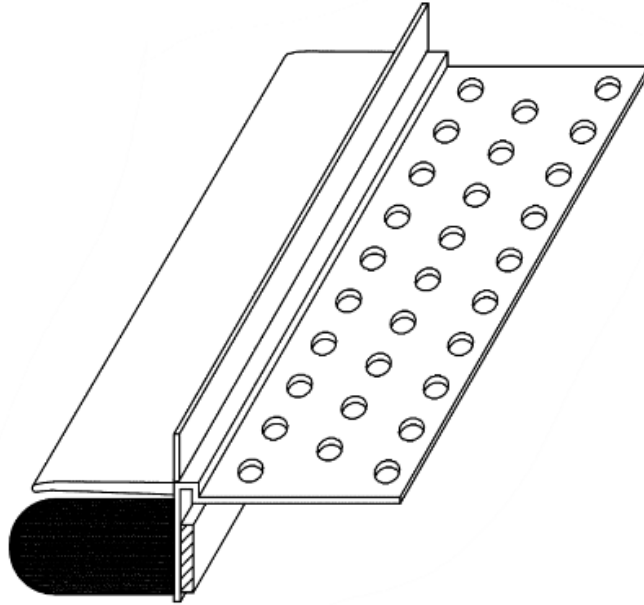

© 2023 UL LLC

This UL Evaluation Report is not an endorsement or recommendation for use of the subject and/or product described herein. This report is not the UL Listing or UL Classification Report that covers the subject product. The subject product's UL Listing or UL Classification is covered under a separate UL Report. UL disclaims all representations and warranties whether express or implied, with respect to this report and the subject or product described herein. Contents of this report may be based on data that has been generated by laboratories other than UL that are accredited as complying with ISO/IEC Standard 17025 by the International Accreditation Service (IAS) or by any other accreditation body that is a signatory to the International Laboratory Accreditation Cooperation (ILAC) Mutual Recognition Arrangement (MRA). The scope of the laboratory's accreditation shall include the specific type of testing covered in the test report. As the accuracy of any non-UL data is the responsibility of the accredited laboratory, UL does not accept responsibility for the accuracy of this data.

