

BRACING ATTACHMENTS

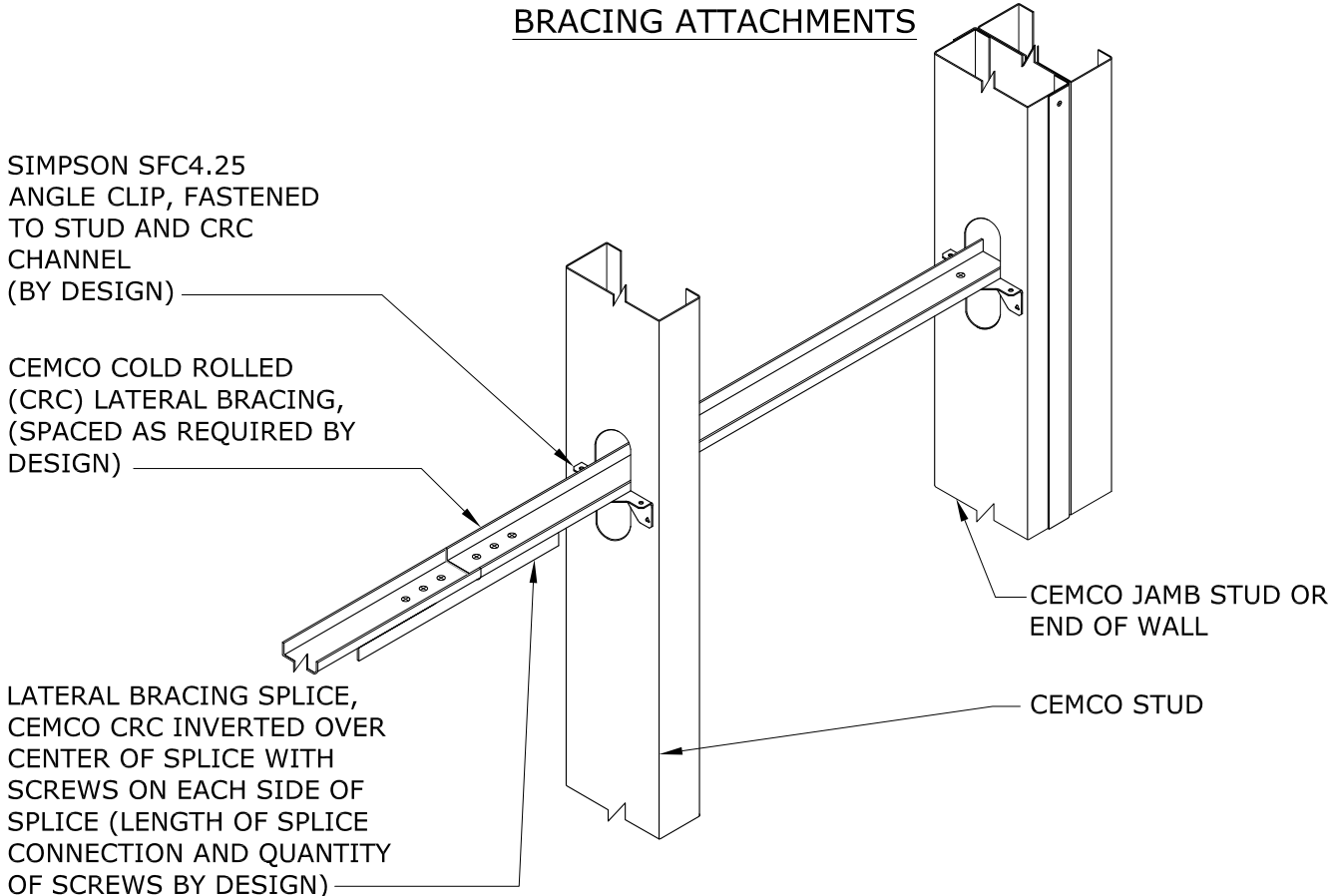

9 BRIDGING - COLD ROLLED CHANNEL WITH CLIP ANGLE SCALE: N.T.S.

CEMCO ENGINEERING

1001-A PITTSBURG ANTIOCH HWY
PITTSBURG, CA 94565
ENG. DEPT. 925.473-9340
FAX 925.473.9124
www.cemcosteel.com

DISCLAIMER:

CEMCO assumes no liability for failure resulting from the use of it's drawings, or for failure resulting from the use of alternate materials, or improper application or installation. This drawing is supplied solely to assist in the selection and application of CEMCO products. This drawing is generic in nature and should not be used in design or construction without an independent evaluation by a qualified Architect or Engineer of Record.

CATEGORY:

LOAD-BEARING DETAILS

REV: 1
RELEASE: 11/21/2019