

## XHBN.HW-D-1066 - Joint Systems

Design/System/Construction/Assembly Usage Disclaimer

- Authorities Having Jurisdiction should be consulted in all cases as to the particular requirements covering the installation and use of UL Certified products, equipment, system, devices, and materials.
- Authorities Having Jurisdiction should be consulted before construction.
- Fire resistance assemblies and products are developed by the design submitter and have been investigated by UL for compliance with applicable requirements. The published information cannot always address every construction nuance encountered in the field.
- When field issues arise, it is recommended the first contact for assistance be the technical service staff provided by the product manufacturer noted for the design. Users of fire resistance assemblies are advised to consult the general Guide Information for each product category and each group of assemblies. The Guide Information includes specifics concerning alternate materials and alternate methods of construction.
- Only products which bear UL's Mark are considered Certified.

## XHBN - Joint Systems

## System No. HW-D-1066

December 31, 2019

## Assembly Ratings — 1 And 2 Hr (See Item 2)

## Nominal Joint Width — 2 -1/2 In.

## Class II Movement Capabilities — 40% Compression Or Extension (See Items 2A and 2A1)

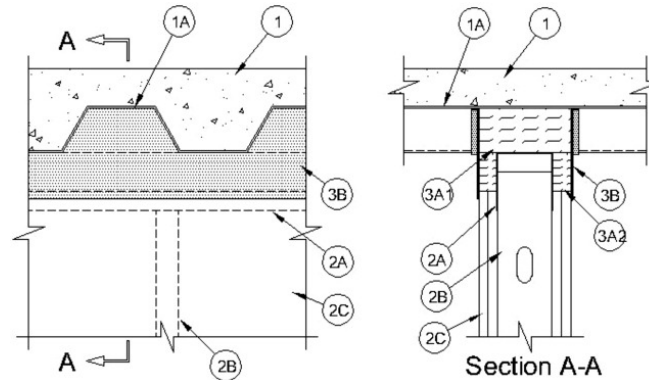

1. **Floor Assembly** — The fire rated fluted steel deck/concrete floor assembly shall be constructed of the materials and in the manner described in the individual D900 Series Floor-Ceiling Design in the UL Fire Resistance Directory and shall include the following construction features:

A. **Steel Floor and Form Units\*** — Max 3 in. (76 mm) deep galv steel fluted floor units.

B. **Concrete** — Min 2-1/2 in. (64 mm) thick reinforced concrete, as measured from the top plane of the floor units.

1A. **Roof Assembly** — (Not Shown) — As an alternate to the floor assembly, a fire rated fluted steel deck roof assembly may be used. The roof assembly shall be constructed of the materials and in the manner described in the individual P900 Series Roof-Ceiling Design in the UL Fire Resistance Directory. The hourly rating of the roof assembly shall be equal to or greater than the hourly rating of the wall assembly. The roof assembly shall include the following construction features:

A. **Steel Roof Deck** — Max 3 in. (76 mm) deep galv steel fluted roof deck.

B. **Roof Insulation** — Min 2-1/4 in. (57 mm) thick poured insulating concrete, as measured from the top plane of the steel roof deck.

2. **Wall Assembly** — The 1 hr or 2 hr fire rated gypsum board/steel stud wall assembly shall be constructed of the materials and in the manner described in the individual U400 or V400 Series Wall and Partition Design in the UL Fire Resistance Directory and shall include the following construction features:

A. **Steel Floor and Ceiling Runners** — Floor and ceiling runners of wall assembly shall consist of galv steel channels sized to accommodate steel studs (Item 2B). Flange height of ceiling runner shall be min 1/4 in. (6 mm) greater than max extended joint width. Ceiling runner installed perpendicular to the deck direction and secured to valleys of deck with steel fasteners, steel masonry anchors or welds spaced max 24 in. (610 mm) OC. If the flange height of ceiling runner is min 1/4 in. (6 mm) greater than the max extended joint width, the max extension of the joint shall not exceed 40 percent of the joint width.

A1. **Light Gauge Framing\* - Slotted Ceiling Runner** — As an alternate to the ceiling runner in Item 2A, slotted ceiling runner to consist of galv steel channel with 3-1/4 in. (83 mm) high slotted flanges sized to accommodate steel studs (Item 2B). Ceiling runner installed perpendicular to direction of fluted steel floor or roof deck and secured to valleys with steel fasteners spaced max 24 in. (610 mm) OC. When slotted ceiling runner is used, the max extension of the joint shall not exceed 20 percent of the joint width.

**BRADY CONSTRUCTION INNOVATIONS INC, DBA SLIPTRACK SYSTEMS** — SLPTRK325

**CALIFORNIA EXPANDED METAL PRODUCTS CO** — CST 325

B. **Studs** — Steel studs to be min 3-1/2 in. (89 mm) wide. Studs cut 1-1/4 in. to 1-1/2 in. (32 to 38 mm) less in length than assembly height with bottom nesting in and resting on floor runner and with top nesting in ceiling runner without attachment. Stud spacing not to exceed 24 in. (610 mm) OC.

C. **Gypsum Board\*** — Gypsum board installed to a min total thickness of 5/8 in. (16 mm) or 1-1/4 in. (32 mm) on each side of wall for 1 hr and 2 hr rated assemblies, respectively. Wall to be constructed as specified in the individual Wall and Partition Design in the UL Fire Resistance Directory, except that a nom 2-1/2 in. (64 mm) gap shall be maintained between the top of the gypsum board and the bottom of the steel deck and the top row of screws shall be installed into the studs 5 in. (127 mm) below the bottom plane of the floor or roof. **The hourly rating of the joint system is dependent on the hourly rating of the wall.**

3. **Joint System** — Max separation between bottom plane of floor or roof and top of gypsum board at time of installation of joint system is 2-1/2 in. (64 mm). The joint system is designed to accommodate a max 40 compression or extension from its installed width. The joint system consists of forming material and a fill material as follows:

A. **Forming Material\*** — Nom 5 in. (127 mm) thick pieces of nom 4 pcf (64 kg/m<sup>3</sup>) forming material sized to attain a min compression rate of 50 percent in the thickness direction firmly packed to completely fill the flutes. Additional pieces of batt insulation, 5/8 or 1-1/4 in. (16 or 32 mm) wide by 5 in. (127 mm) thick, shall be compressed 50 percent in thickness and installed cut edge first into gap between bottom of fluted floor or roof units and top of gypsum board.

**ROCK WOOL MANUFACTURING CO** — Delta Board

**ROCKWOOL** — SAFE

**THERMAFIBER INC** — Type SAF

A1. **Forming Material\*—Plugs** — As an alternate to Item 3A, preformed mineral wool plugs, formed to the shape of the fluted floor units, friction fit to completely fill the flutes above the ceiling runner. The plugs shall project beyond each side of the ceiling runner, flush with wall surfaces. Additional forming material, described in Item 3A2, to be used in conjunction with the plugs to fill the gap between the top of gypsum board and the bottom of plug.

**HILTI CONSTRUCTION CHEMICALS, DIV OF HILTI INC** — CP777 Speed Plugs

A2. **Forming Material\* - Strips** — Nom 5/8 in. (16 mm) and 1-1/4 in. (32 mm) wide by 5 in. (127 mm) thick precut mineral wool strips for 1 and 2 hr rated assemblies, respectively. The strips are compressed 50 percent in thickness and firmly packed into the gap between the top of the gypsum board and bottom of the steel floor or roof deck on both sides of the wall.

**HILTI CONSTRUCTION CHEMICALS, DIV OF HILTI INC** — CP 767 Speed Strips

B. **Fill, Void or Cavity Material\*** — Min 1/16 in. (1.6 mm) dry thickness (min 1/8 in. or 3.2 mm wet thickness) of fill material sprayed on each side of the wall to completely cover mineral wool forming material and to overlap a min of 1/2 in. (13 mm) onto gypsum board and steel deck on both sides of wall.

**HILTI CONSTRUCTION CHEMICALS, DIV OF HILTI INC** — CP672 Firestop Spray or CFS-SP-WB Firestop Joint Spray

\* Indicates such products shall bear the UL or cUL Certification Mark for jurisdictions employing the UL or cUL Certification (such as Canada), respectively.

Last Updated on 2019-12-31

