

## XHBN.HW-D-0781 - Joint Systems

Design/System/Construction/Assembly Usage Disclaimer

- Authorities Having Jurisdiction should be consulted in all cases as to the particular requirements covering the installation and use of UL Certified products, equipment, system, devices, and materials.
- Authorities Having Jurisdiction should be consulted before construction.
- Fire resistance assemblies and products are developed by the design submitter and have been investigated by UL for compliance with applicable requirements. The published information cannot always address every construction nuance encountered in the field.
- When field issues arise, it is recommended the first contact for assistance be the technical service staff provided by the product manufacturer noted for the design. Users of fire resistance assemblies are advised to consult the general Guide Information for each product category and each group of assemblies. The Guide Information includes specifics concerning alternate materials and alternate methods of construction.
- Only products which bear UL's Mark are considered Certified.

## XHBN - Joint Systems

### XHBN7 - Joint Systems Certified for Canada

[See General Information for Joint Systems](#)

[See General Information for Joint Systems Certified for Canada](#)

#### System No. HW-D-0781

December 31, 2019

ANSI/UL2079	CAN/ULC S115
Assembly Ratings — 1 and 2 Hr (See Item 2)	F Ratings — 1 and 2 Hr (See Item 2)
	FT Ratings —1 and 2 Hr (See Item 2)
	FH Ratings —1 and 2 Hr (See Item 2)
	FTH Ratings —1 and 2 Hr (See Item 2)
Nominal Joint Width — 1 In.	Nominal Joint Width — 25 mm
Class II or III Movement Capabilities — 25% Compression (See Item 2)	Class II or III Movement Capabilities — 25% Compression (See Item 2)

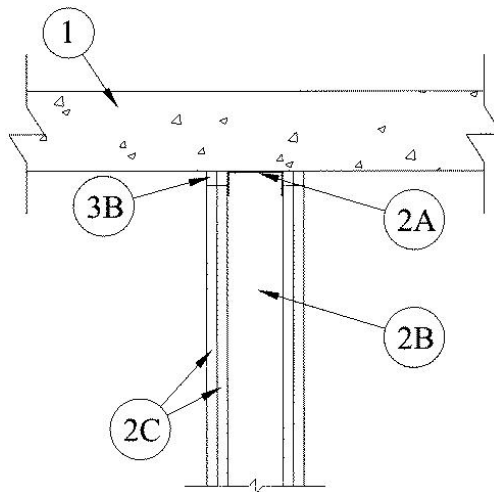

- 1. Floor Assembly** — Min 4-1/2 in. (114 mm) thick reinforced lightweight or normal weight (100-150 pcf (1600-2400 kg/m<sup>3</sup>)) structural concrete.
- 2. Wall Assembly** — The 1 or 2 h fire-rated gypsum board/steel stud wall assembly shall be constructed of the materials and in the manner described in the individual U400 or V400 Series Wall and Partition Designs in the UL Fire Resistance Directory and shall include the following construction features:
- A. Steel Floor and Ceiling Runners** — Floor runners of wall assembly shall consist of galv steel channels sized to accommodate steel studs (Item 2B). Ceiling runners of wall assembly shall consist of min No. 26 gauge galv steel channels sized to accommodate steel studs (Item 2B). Ceiling runners to be provided with 2 in. (51 mm) flanges. Ceiling runner secured to lower surface of floor with steel fasteners spaced max 7 in. (178 mm) OC.
- A1. Light Gauge Framing\* — Floor and Ceiling Runners** — As an alternate to the ceiling and floor runners in Item 2A and 2A1, floor and ceiling runners to consist of galv steel channel sized to accommodate the **Light Gauge Framing\* Slotted Stud** (Item 2B1) or **Light Gauge Framing\* Slider C-Clip System** (Item 2B2). Floor and ceiling runners to be provided with min 1-1/4 in. (32 mm) and 3 in. (76 mm) flanges, respectively. Ceiling runner secured to lower surface of floor with steel fasteners spaced max 12 in. (305 mm) OC.  
**STEELER INC** — Floor and Ceiling Runners
- A3. Light Gauge Framing\* - Slotted Ceiling Runner** — As an alternate to the ceiling runner in Items 2A, 2A1 and 2A2, slotted ceiling runner to consist of galv steel channel with slotted flanges sized to accommodate steel studs (Item 2B). Ceiling runner secured to concrete floor with steel fasteners spaced max 24 in. (610 mm) OC.  
**SCAFCO STEEL STUD MANUFACTURING CO**  
**BRADY CONSTRUCTION INNOVATIONS INC, DBA SLIPTRACK SYSTEMS** — SLP-TRK  
**CALIFORNIA EXPANDED METAL PRODUCTS CO** — CST  
**STEELER INC** — Steeler Slotted Ceiling Runner  
**TELLING INDUSTRIES L L C** — True-Action Deflection Track
- A4. Light Gauge Framing\* - Notched Ceiling Runner** — As an alternate to the ceiling runners in Items 2A through 2A3, notched ceiling runners to consist of C-shaped galv steel channel with notched return flanges sized to accommodate steel studs (Item 2B). Notched ceiling runner secured to concrete floor slab with steel masonry anchors spaced max 24 in. (610 mm) OC. When notched ceiling runner is used, deflection channel (Item 3A) shall not be used.  
**OLMAR SUPPLY INC** — Type SCR
- A5. Light Gauge Framing\* — Vertical Deflection Clip** — (Optional) Steel clips can be used in conjunction with steel studs (Item 2B) or ceiling runner (Item 2A). Clips installed over the top of studs and inserted within the ceiling runner. Clip shall be secured to the ceiling runner with No. 8 self drilling, self tapping steel fasteners through holes provided within the clip. Clip may be secured to the stud with No. 6 pan head steel screw through holes provided within the clip. As an alternate, the legs of the clip may be installed over the top of the stud without attachment in accordance with manufacturer's installation instructions.  
**FLEX-ABILITY CONCEPTS L L C** — Three Legged Dog Deflection Clip
- B. Studs** — Steel studs to be min 2-1/2 in. (64 mm) wide. Studs cut 1 in. (25 mm) less in length than assembly height with bottom nesting in and resting on floor runner and with top nesting in ceiling runner without attachment. When slotted ceiling runner (Item 2A3) is used, steel studs secured to slotted ceiling runner with No. 8 by 1/2 in. (13 mm) long wafer head steel screws at midheight of slot on each side of wall. Stud spacing not to exceed 24 in. (610 mm) OC.
- B1. Light Gauge Framing\* — Slotted Studs** — Slotted steel stud to be used in conjunction with **Light Gauge Framing\* — Floor and Ceiling Runners** (Item 2A4). Slotted steel studs to be min 2-1/2 in. (64 mm) wide. Slotted steel studs cut 1 in. (25 mm) less in length than assembly height with bottom nesting in and secured to both ceiling and floor runners. Ceiling runner secured to preformed slot within steel stud by means of No. 10 by 3/4 in. (19 mm) long low profile head steel screw. Floor runner attached to bottom of steel stud by means of No. 8 by 1/2 in. (13 mm) long pan head steel screw. Slotted steel stud spacing not to exceed 24 in. (610 mm) OC.  
**STEELER INC** — Slotted Stud
- B2. Light Gauge Framing\* — Slider C-Clip System** — As an alternate to the **Light Gauge Framing\* — Slotted Steel Studs** (Item 2B1), a Slider C-Clip System consisting of a C shaped steel clip with a slotted opening and a steel stud to be used in conjunction with **Light Gauge Framing\* — Floor and Ceiling Runners** (Item 2A2). Steel clips and studs to be min 2-1/2 in. (64 mm) wide. Steel clip inserted into inside flange of steel stud without attachment. Total length of steel stud cut 1 in. (25 mm) less than assembly height with bottom of steel

stud nesting in and secured to floor runner. Floor runner attached to bottom of steel stud by means of No. 8 by 1/2 in. (13 mm) long pan head steel screw. Ceiling runner secured to steel C-Clip by means of No. 10 by 3/4 in. (19 mm) long pan head steel screw located 3/8 in. (10 mm) below top of ceiling runner. Top row of gypsum board screws shall be centered within the preformed slot of the C-Clip. Steel stud and steel clips spacing not to exceed 24 in. (610 mm) OC.  
**STEELER INC** — Slider C Clip System

C. **Gypsum Board\*** — Gypsum board sheets installed to a min total thickness of 5/8 or 1-1/4 in. (16 or 32 mm) on each side of wall for a 1 or 2 h fire rated wall, respectively. Wall to be constructed as specified in the individual Wall and Partition Design in the UL Fire Resistance Directory, except that a max 1 in. (25 mm) gap shall be maintained between the top of the gypsum board and the lower surface of the floor. The top row of screws shall be installed into the studs 4 in. (102 mm) below the lower surface of the floor. The hourly fire rating of the joint system is equal to the hourly fire rating of the wall.

**The hourly fire rating of the joint system is equal to the hourly fire rating of the wall. The movement capability of the joint system is Class II and III except that when the vertical deflection clip (Item 2A5) is used, the movement capability is Class II only.**

3. **Joint System — Max separation between bottom of floor and top of wall (at time of installation of joint system) is 1 in. (25 mm). The joint system is designed to accommodate a max 25 percent compression from its installed width.** The joint system consists of a packing or forming material and a fill material between the top of the wallboard and the bottom of the floor, as follows:

A. **Packing Material** — (Optional, Not Shown)—For 2 h rated systems, two layers of nom 7/8 in. (22 mm) diam polyurethane backer rod friction-fitted on top of each other into the gap between the top of the gypsum board and the bottom of the concrete floor on both sides of the wall and recessed from each surface of wall to accommodate the required thickness of fill material.

A1. **Forming Material\*** — (Optional, Not Shown)—For 2 h rated systems, min 3/4 in. (19 mm) width of 4 pcf (64 kg/m<sup>3</sup>) mineral wool batt insulation compressed 50 percent in thickness and packed into the gap between the top of the gypsum board and bottom of the floor on both sides of the wall.

**INDUSTRIAL INSULATION GROUP L L C** — MinWool-1200 Safing

**ROCK WOOL MANUFACTURING CO** — Delta Board or Delta-8

**ROCKWOOL MALAYSIA SDN BHD** — Type Safe

**ROCKWOOL** — Type Safe

**THERMAFIBER INC** — Type SAF

B. **Fill, Void or Cavity Material\*** — A min 1/2 in. (13 mm) thickness of fill material installed on each side of the wall between the top of the gypsum board and bottom of the concrete floor. As an option for 1 hr systems and in 2 hr systems where packing material (Item 3A) or forming material (Item 3B) are not used, bond breaker tape may be applied to ceiling runner on each side of wall.

**DAP PRODUCTS INC** — DAP Fire Stop Fire-Rated Silicone Sealant

**\* Indicates such products shall bear the UL or cUL Certification Mark for jurisdictions employing the UL or cUL Certification (such as Canada), respectively.**

[Last Updated](#) on 2019-12-31

The appearance of a company's name or product in this database does not in itself assure that products so identified have been manufactured under UL's Follow-Up Service. Only those products bearing the UL Mark should be considered to be Certified and covered under UL's Follow-Up Service. Always look for the Mark on the product.

UL permits the reproduction of the material contained in the Online Certification Directory subject to the following conditions: 1. The Guide Information, Assemblies, Constructions, Designs, Systems, and/or Certifications (files) must be presented in their entirety and in a non-misleading manner, without any manipulation of the data (or drawings). 2. The statement "Reprinted from the Online Certifications Directory with permission from UL" must appear adjacent to the extracted material. In addition, the reprinted material must include a copyright notice in the following format: "© 2022 UL LLC"