

## XHBN.HW-D-0653 - Joint Systems

Design/System/Construction/Assembly Usage Disclaimer

- Authorities Having Jurisdiction should be consulted in all cases as to the particular requirements covering the installation and use of UL Certified products, equipment, system, devices, and materials.
- Authorities Having Jurisdiction should be consulted before construction.
- Fire resistance assemblies and products are developed by the design submitter and have been investigated by UL for compliance with applicable requirements. The published information cannot always address every construction nuance encountered in the field.
- When field issues arise, it is recommended the first contact for assistance be the technical service staff provided by the product manufacturer noted for the design. Users of fire resistance assemblies are advised to consult the general Guide Information for each product category and each group of assemblies. The Guide Information includes specifics concerning alternate materials and alternate methods of construction.
- Only products which bear UL's Mark are considered Certified.

## XHBN - Joint Systems

### XHBN7 - Joint Systems Certified for Canada

[See General Information for Joint Systems](#)

[See General Information for Joint Systems Certified for Canada](#)

#### System No. HW-D-0653

July 03, 2018

ANSI/UL2079

CAN/ULC S115

ANSI/UL2079	CAN/ULC S115
Assembly Ratings — 1 and 2 Hr (See Item 2)	F Ratings — 1 and 2 Hr (See Item 2)
Nominal Joint Width — 5/8, 3/4 or 1 In.	FT Ratings — 1 and 2 Hr (See Item 2)
Class II or III Movement Capabilities — 100% Compression or Extension	FH Ratings — 1 and 2 Hr (See Item 2)
L Rating At Ambient — Less Than 1 CFM/Lin Ft	FTH Ratings — 1 and 2 Hr (See Item 2)
L Rating At 400°F — Less Than 1 CFM/Lin Ft	Nominal Joint Width — 5/8, 3/4 or 1 In.
The Air leakage Rating Does not apply if item 1E.1 is used.	Class II or III Movement Capabilities — 100% Compression or Extension
	L Rating At Ambient — Less Than 1 CFM/Lin Ft
	L Rating At 400°F — Less Than 1 CFM/Lin Ft
	The Air leakage Rating Does not apply if item 1E.1 is used.

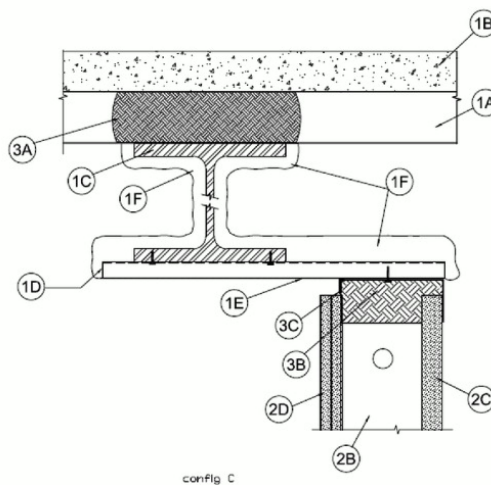
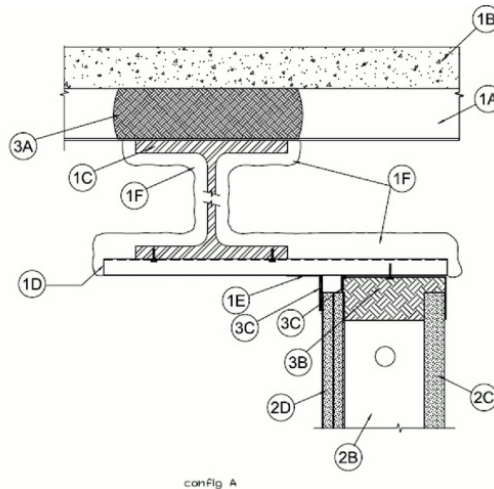

**1. Floor Assembly** — The fire-rated fluted steel deck/concrete floor assembly shall be constructed of the materials and in the manner described in the individual D700 or D900 Series Floor-Ceiling Design in the UL Fire Resistance Directory and shall include the following construction features:

**A. Steel Floor And Floor Units\*** — Max 3 in. (76 mm) deep galv steel fluted floor units.

**B. Concrete** — Min 2-1/2 in. (64 mm) thick reinforced concrete, as measured from the top plane of the floor units.

**C. Structural Steel Support** — Steel beam, as specified in the individual D700 or D900 Series Floor-Ceiling Design, used to support steel floor units. Structural steel support oriented parallel to and 8 in. (203 mm) max from wall assembly.

**D. Steel Attachment Clips** — 1 in. (25 mm) wide Z-shaped clips or channels formed from min 20 ga galv or painted steel. Clips to be sized to extend through the thickness of the spray-applied fire-resistive material on the bottom flange of the steel beam with 1-1/2 in. (38 mm) long upper and lower legs. Legs of clips fastened to bottom of beam (prior to application of spray-applied fire-resistive materials) with steel fasteners or welds and to ceiling runner of wall with bolts or screws. Clips spaced max 16 in. (406 mm) OC and extend from steel support beam to flush with non-beam face of wall.

**E. Steel Plate** — Min 22 Ga sheet steel shall be installed under and attached to the steel attachment clips or channels (Item 1D) to completely cover the exposed area from the flange tip of the steel beam to the framed wall surface. The plate shall be secured with steel fasteners or welds and shall be covered with spray applied fire resistive material (see Item 1F).

**E1. Steel Lath** — as alternate to E. Nom 3/8 in. (10 mm) diamond mesh expanded steel rib lath having a nom weight of 3.4 lb/yd<sup>2</sup> (1.8 kg/m<sup>2</sup>) shall be installed over and attached to the steel attachment clip bars or channels (Item 1D) to completely cover the exposed area from the flange tip of the steel beam to the end of the bar/channel framing extending beyond the wall surface. The lath shall be secured with steel fasteners or tie wire and shall be fully covered with spray applied fire resistive material (Item 1F).

F. **Spray-Applied Fire Resistive Material\*** — After installation of the steel attachment clips, steel plate, angle, ceiling runners, structural steel support, and steel floor units (as applicable), to be sprayed with the min thickness of material specified in the individual D700 or D900 Series Design. Each steel attachment clip is to be fully covered with spray applied fire resistive material to the minimum thickness of material required on the flanges of the steel beam. The spaces between the clips and above the steel plate (Item 1E) shall also be fully filled from beam and over the entire thickness of the wall. The spaces between the clips and above and below the steel lath (Item 1E.1) shall also be fully filled from beam and over the entire thickness of the wall. Additional material shall be applied to the web of steel beam on each side of wall. The min total thickness of material applied to each side of steel beam web shall be 13/16 in. (21 mm) for 1 hr Assembly Rating and 1-1/2 in. (38 mm) for 2 hr Assembly Rating. When Item 3A is not used, the flutes of the steel floor units are to be filled with material across the entire top flange of the steel beam. For D700 floors, the remainder of the steel floor units shall be sprayed as specified in the individual D700 design.  
**ISOLATEK INTERNATIONAL** — Type 300

**GCP APPLIED TECHNOLOGIES INC** — Type MK-6/HY

1A. **Roof Assembly — (Not Shown)** — As an alternate to the floor assembly, a fire-rated fluted steel deck roof assembly may be used. The roof assembly shall be constructed of the materials and in the manner described in the individual P700 or P900 Series Roof-Ceiling Design in the UL Fire Resistance Directory. The roof assembly shall include the following construction features:

A. **Steel Roof Deck** — Max 3 in. (76 mm) deep galv steel fluted roof deck.

B. **Roof Insulation** — Min 2-1/4 in. (57 mm) thick poured insulating concrete, as measured from the top plane of the roof deck.

C. **Structural Steel Support** — Steel beam, as specified in the individual P700 or P900 Series Design, used to support steel floor units. Structural steel support oriented parallel to and 8 in. (203 mm) max from wall assembly.

D. **Steel Attachment Clips** — 1 in. (25 mm) wide Z-shaped clips or channels formed from min 20 ga galv or painted steel. Clips to be sized to extend through the thickness of the spray-applied fire-resistive material on the bottom flange of the steel beam with 1-1/2 in. (38 mm) long upper and lower legs. Legs of clips fastened to bottom of beam (prior to application of spray-applied fire-resistive materials) with steel fasteners or welds and to ceiling runner of wall with bolts or screws. Clips spaced max 16 in. (406 mm) OC and extend from steel support beam to flush with non-beam face of wall.

E. **Steel Plate** — Min 22 Ga sheet steel shall be installed under and attached to the steel attachment clips or channels (Item 1D) to completely cover the exposed area from the flange tip of the steel beam to the framed wall surface. The plate shall be secured with steel fasteners or welds and shall be covered with spray applied fire resistive material (see Item 1F).

E1. **Steel Lath** — as alternate to E. Nom 3/8 in. (10 mm) diamond mesh expanded steel rib lath having a nom weight of 3.4 lb/yd<sup>2</sup> (1.8 kg/m<sup>2</sup>) shall be installed over and attached to the steel attachment clip bars or channels (Item 1D) to completely cover the exposed area from the flange tip of the steel beam to the end of the bar/channel framing extending beyond the wall surface. The lath shall be secured with steel fasteners or tie wire and shall be fully covered with spray applied fire resistive material (Item 1F).

F. **Spray-Applied Fire Resistive Material\*** — After installation of the steel attachment clips, steel plate, angles, ceiling runners, structural steel support, and roof deck (as applicable), to be sprayed with the min thickness of material specified in the individual P700 or P900 Series Design. Each steel attachment clip is to be fully covered with spray applied fire resistive material to the minimum thickness of material required on the flanges of the steel beam. The spaces between the clips and above the steel plate (Item 1E) shall also be fully filled from beam and over the entire thickness of the wall. The spaces between the clips and above and below the steel lath (Item 1E.1) shall also be fully filled from beam and over the entire thickness of the wall. Additional material shall be applied to the web of steel beam on each side. The min total thickness of material applied to each side of steel beam web shall be 13/16 in. (21 mm) for 1 hr Assembly Rating and 1-1/2 in. (38 mm) for 2 hr Assembly Rating. When Item 3A is not used, the flutes of the roof deck are to be filled with material across the entire top flange of the steel beam. For P700 roof-ceiling assemblies, the remainder of the roof deck shall be sprayed as specified in the individual P700 design.  
**ISOLATEK INTERNATIONAL** — Type 300

**GCP APPLIED TECHNOLOGIES INC** — Type MK-6/HY

1B. **Floor Assembly — (Not Shown)** — Min 4-1/2 in. thick reinforced lightweight or normal weight (100 to 150 pcf) structural concrete.

2. **Shaft Wall Assembly** — The 2 hr fire rated gypsum board/stud wall assembly shall be constructed of the materials and in the manner described in the individual U400 or V400 Series Wall and Partition Design in the UL Fire Resistance Directory and shall include the following construction features:

A. **Steel Floor and Ceiling Runners** — Floor runner U-shaped, sized to accommodate steel studs (Item 2B), fabricated from 25 ga galv steel. Ceiling runner positioned with slotted leg toward finished side of wall. Legs are to be min 1/4 in. (6 mm) longer than the maximum joint width. Runners attached to steel attachment clips through gypsum board (Item 1E) with min 1/2 in. (13 mm) long steel fasteners, minimum one fastener per clip. The ceiling runners are provided with a fill, void or cavity material and are described in Item 3. A 1-1/2 by 1-1/2 in. (38 x 38 mm) galvanized steel angle shall be attached to top of ceiling runner on non-beam side of wall with No. 8 sheet metal screws spaced 16 in. (406 mm) max on center and 1 in. (25 mm) max from ends. Ceiling runner to be installed parallel with structural steel support and located such that a max clearance of 8 in. (203 mm) is present between the finished wall and the flange of the steel beam (Item 1C).

A.1. **Light Gauge Framing\* — Slotted Ceiling Track** — (Not Shown) - As an alternate to the Item 2A, a ceiling track consisting of galv steel channel with slotted flanges may be used when Item 3C.1 or 3C.2 fill material is utilized. Slotted ceiling track sized to accommodate steel studs (Item 2B). Legs are to be min 1/4 in. (6 mm) longer than the maximum joint width. Attached to steel deck with steel fasteners or welds spaced max 24 in. (610 mm) OC.

**BRADY CONSTRUCTION INNOVATIONS INC, DBA SLIPTRACK SYSTEMS** — SLP-TRK

**CALIFORNIA EXPANDED METAL PRODUCTS CO** — CST, CST 325

**MARINO/WARE, DIV OF WARE INDUSTRIES INC** — Type SLT

B. **Studs** — "C-T", "I", or "C-H" shaped steel studs to be min 2 1/2 in. (64 mm) wide and formed of min 25 ga galv steel. Studs cut 1 to 1-1/4 in (25 to 32 mm) less in length than assembly height with bottom nesting in and secured to floor runner. Steel studs secured to slotted leg of ceiling runner on finished side with No. 8 by 1/2 (13 mm) long wafer head steel screws at mid-height of exposed slot. Studs spaced max 24 in. (610 mm) OC.

C. **Gypsum Board\*** — 1 in. (25 mm) thick by max 24 in. (610 mm) wide gypsum board liner panels. Panels cut 1-1/2 in. (38 mm) less in length than floor to ceiling height. Vertical edges inserted into "T" shaped section of "C-T" studs, into holding tabs of "I" studs or into "H"-shaped section of "C-H" studs.

D. **Gypsum Board\*** — Gypsum board 1/2 or 5/8 in. (13 or 16 mm) thick, applied on finished side of wall as specified in the individual Wall and Partition Design. The boards cut a max 5/8 in. (16 mm) less in length than the floor to ceiling height. The screws attaching the gypsum board layer(s) to the "C-T", "I", or "C-H" studs shall be located 4 to 5 in. (102 to 127 mm) down from deck at time of installation.

E. **Gypsum Board\*** — (Not Shown, Required for use with Item 3C) A nominal 3-5/8 in. (92 mm) wide rip of gypsum board covering the leg of the ceiling runner attached a max of 3/8 in. (10 mm) below the track web and a max of 8 in. (203 mm) O.C. to ceiling runner on the non-finished side of wall.

**The hourly rating of the joint system is equal to the hourly fire rating of the wall.**

## Configuration A

3. **Joint System — Max separation between floor or roof deck or bottom of spray-applied fire resistive material on steel floor or roof unit and top of wall (at time of installation of joint system) is 5/8 in. (25 mm). The joint system is designed to accommodate a max 100 percent compression or extension from its installed width. When Item 3C.2 is used the nominal joint width is 3/8 in. (10 mm).**

A. **Forming Material\*** — Min 4 pcf (64 kg/m<sup>3</sup>) mineral wool insulation cut to the shape of the fluted steel floor or roof deck units, approx 33% larger than the area of the flutes. Pieces compressed and inserted into and completely filling the flutes above the structural support member. As an option, the spray-applied fire resistive material described in Item 1 can be used in place of the packing material.  
**INDUSTRIAL INSULATION GROUP L L C** — MinWool-1200 Safing

**JOHNS MANVILLE** — Safing

**ROCK WOOL MANUFACTURING CO** — Delta Safing Board

**ROCKWOOL MALAYSIA SDN BHD** — SAFE

**ROCKWOOL** — SAFE

**THERMAFIBER INC** — SAF

A1. **Forming Material\* - Plugs** — (Not Shown) — As an alternate to the forming material (Item 3A), mineral wool plugs preformed to the shape of the fluted floor units, may be used within the flutes. Plugs shall be friction fit to completely fill the flutes above the structural member. The plugs shall project beyond each side of the structural member.

**ROCK WOOL MANUFACTURING CO** — Delta Deck Plugs

B. **Forming Material\*** — Min 3 in. thick min 4 pcf (64 kg/m<sup>3</sup>) mineral wool batt insulation cut to the width of the ceiling runner and compressed 50 percent in thickness, installed into ceiling runner between leg of track and gypsum liner board.

**INDUSTRIAL INSULATION GROUP L L C** — MinWool-1200 Safing

**JOHNS MANVILLE** — Safing

**ROCK WOOL MANUFACTURING CO** — Delta Safing Board

**ROCKWOOL MALAYSIA SDN BHD** — SAFE

**ROCKWOOL** — SAFE

**THERMAFIBER INC** — SAF

C. **Fill, Void or Cavity Material\*** — Nom 20 ga U-shaped track having 3 in (76 mm) legs with a nom 1-1/4 in. (32 mm) wide intumescent strip affixed on top surface a min of 1/4 in. (6 mm). Track to be secured to steel attachment clips with min No 8 by 1/2 in. (13 mm) long steel fasteners spaced at a max of 16 in. (406 mm) OC (min one fastener into each clip).  
**CALIFORNIA EXPANDED METAL PRODUCTS CO** — FAS Shaft Track

C1. **Fill, Void or Cavity Material\*** — (Not Shown) as an alternate to 3C a min. 25 ga composite steel angle with one 5/8 in. (16 mm) leg and one 2-1/2 in (64 mm) leg with a 5/8 in. (16 mm) strip of intumescent strip affixed along the inside 2-1/2 in (64 mm) leg. The 5/8 in.(16 mm) leg is friction fit between the top web of the ceiling runner and Item 1D steel attachment clips on the finish side only.  
**CALIFORNIA EXPANDED METAL PRODUCTS CO** — DDA (Deflection Drift Angle)

C2. **Fill, Void or Cavity Material\*** — As an alternate to Item 3C Nom 20ga J-shaped track having a one 1-1/2" in. solid leg and one 2-1/2 in. leg nom 1/2 in. (13 mm) wide intumescent strip affixed to the top outer web along the outside corner facing the finish side of the wall. Track to be secured to bottom side of floor assembly with steel masonry or powder actuated fasteners spaced at a max of 24 in. (610 mm) OC.  
**CALIFORNIA EXPANDED METAL PRODUCTS CO** — Fire Rated J-Track

**MARINO/WARE, DIV OF WARE INDUSTRIES INC** — Fire Rated J-Track

**UNITED STATES GYPSUM CO** — USG Sheetrock® Brand Firecode® J-Runner

D. **Fill, Void or Cavity Material\*** — **Sealant** — (Not Shown) -Sealant may be used to seal any gaps at end joints between ceiling runners, and gaps above ceiling runner, to maintain L Ratings.

E. **Fill, Void or Cavity Material\*** — A nom 20 gauge steel angle provided with a nom 1 in. (25 mm) wide intumescent strip on one leg. Angle to be secured to the steel attachment clips (Item 1D) with min No. 8 steel sheet metal screws such that the intumescent strip is flat against the outer surface of the wall.  
**CALIFORNIA EXPANDED METAL PRODUCTS CO** — Firestik FS1

## Configuration B (Not Shown, 1 in. version of A)

3. **Joint System** — Max separation between floor or roof deck or bottom of spray-applied fire resistive material on steel floor or roof unit and top of wall (at time of installation of joint system) is 1 in. (25 mm). The joint system is designed to accommodate a max 100 percent compression or extension from its installed width. When Item 2A.1 is used the nominal joint width is max 3/4 in. (19 mm). When Item 3C.2 is used the max nominal joint is 1/2 in. (13 mm). When Item 3C.3 is used the nominal joint width is 3/8 in. (10 mm).

A. **Forming Material\*** — Min 4 pcf (64 kg/m<sup>3</sup>) mineral wool insulation cut to the shape of the fluted steel floor or roof deck units, approx 33% larger than the area of the flutes. Pieces compressed and inserted into and completely filling the flutes above the structural support member. As an option, the spray-applied fire resistive material described in Item 1 can be used in place of the packing material.  
**INDUSTRIAL INSULATION GROUP L L C** — MinWool-1200 Safing

**JOHNS MANVILLE** — Safing

**ROCK WOOL MANUFACTURING CO** — Delta Safing Board

**ROCKWOOL MALAYSIA SDN BHD** — SAFE

**ROCKWOOL** — SAFE

**THERMAFIBER INC** — SAF

A1. **Forming Material\* - Plugs** — (Not Shown) — As an alternate to the forming material (Item 3A), mineral wool plugs preformed to the shape of the fluted floor units, may be used within the flutes. Plugs shall be friction fit to completely fill the flutes above the structural member. The plugs shall project beyond each side of the structural member.  
**ROCK WOOL MANUFACTURING CO** — Delta Deck Plugs

B. **Forming Material\*** — Min 3 in. thick min 4 pcf (64 kg/m<sup>3</sup>) mineral wool batt insulation cut to the width of the ceiling runner and compressed 50 percent in thickness, installed into ceiling runner between leg of track and gypsum liner board.  
**INDUSTRIAL INSULATION GROUP L L C** — MinWool-1200 Safing

**JOHNS MANVILLE** — Safing

**ROCK WOOL MANUFACTURING CO** — Delta Safing Board

**ROCKWOOL MALAYSIA SDN BHD** — SAFE

**ROCKWOOL** — SAFE

**THERMAFIBER INC** — SAF

C. **Fill, Void or Cavity Material\*** — Nom 20 ga U-shaped track having 3 in (76 mm) legs with a nom 2-1/2 in. (64 mm) wide intumescent strip affixed to the top of each leg overlapping on to top surface a min of 1/4 in. (6 mm). Track to be secured to steel attachment clips with min No 8 by 1/2 in. (13 mm) long steel fasteners spaced at a max of 16 in. (406 mm) OC (min one fastener into each clip).  
**CALIFORNIA EXPANDED METAL PRODUCTS CO** — FAS Shaft Track DL2

C1. **Fill, Void or Cavity Material\*** — (Not Shown) as an alternate to 3C a min. 25 ga composite steel angle with one 5/8 in. (16 mm) leg and one 2-1/2 in (64 mm) leg with a 5/8 in. (16 mm) strip of intumescent strip affixed along the inside 2-1/2 in (64 mm) leg. The 5/8 in.(16 mm) leg is friction fit between the top web of the ceiling runner and Item 1D steel attachment clips on the finish side only.  
**CALIFORNIA EXPANDED METAL PRODUCTS CO** — DDA (Deflection Drift Angle)

C2. **Fill, Void or Cavity Material\*** — As an option to item 3A a min 25 ga composite steel angle with one 5/8 in. (16 mm) leg and one 1-1/4 in (32 mm) leg with a strip of intumescent strip affixed along the inside 1-1/4 in (32 mm) leg. Steel angle is friction fit between the top web of the ceiling runner and the concrete deck.  
**CALIFORNIA EXPANDED METAL PRODUCTS CO** — DDA-1 (Deflection Drift Angle)

C3. **Fill, Void or Cavity Material\*** — As an alternate to Item 3C Nom 20ga J-shaped track having a one 1-1/2" in. solid leg and one 2-1/2 in. leg nom 1/2 in. (13 mm) wide intumescent strip affixed to the top outer web along the outside corner facing the finish side of the wall. Track to be secured to bottom side of floor assembly with steel masonry or powder actuated fasteners spaced at a max of 24 in. (610 mm) OC.  
**CALIFORNIA EXPANDED METAL PRODUCTS CO** — Fire Rated J-Track

**UNITED STATES GYPSUM CO** — USG Sheetrock® Brand Firecode® J-Runner

**MARINO/WARE, DIV OF WARE INDUSTRIES INC** — Fire Rated J-Track

D. **Fill, Void or Cavity Material\*** — A nom 20 gauge steel angle provided with a nom 1 in. or 2 in. (25 mm) wide intumescent strip on one leg. Angle to be secured to the steel attachment clips (Item 1D) with min No. 8 steel sheet metal screws such that the intumescent strip is flat against the outer surface of the wall.  
**CALIFORNIA EXPANDED METAL PRODUCTS CO** — Firestik FS2

## Configuration C

3. **Joint System** — Max separation between floor or roof deck or bottom of spray-applied fire resistive material on steel floor or roof unit and top of wall (at time of installation of joint system) is 5/8 in. (16 mm). When Item 3C.2 is used the max nominal joint is 1/2 in. (13 mm). The joint system is designed to accommodate a max 100 percent compression or extension from its installed width. When Item 3C.3 is used the nominal joint width is 3/8 in. (10 mm).

A. **Forming Material\*** — Min 4 pcf (64 kg/m<sup>3</sup>) mineral wool insulation cut to the shape of the fluted steel floor or roof deck units, approx 33% larger than the area of the flutes. Pieces compressed and inserted into and completely filling the flutes above the structural support member. As an option, the spray-applied fire resistive material described in Item 1 can be used in place of the packing material.  
**INDUSTRIAL INSULATION GROUP L L C** — MinWool-1200 Safing

**JOHNS MANVILLE** — Safing

**ROCK WOOL MANUFACTURING CO** — Delta Safing Board

**ROCKWOOL MALAYSIA SDN BHD** — SAFE

ROCKWOOL — SAFE

THERMAFIBER INC — SAF

A1. **Forming Material\* - Plugs** — (Not Shown) — As an alternate to the forming material (Item 3A), mineral wool plugs preformed to the shape of the fluted floor units, may be used within the flutes. Plugs shall be friction fit to completely fill the flutes above the structural member. The plugs shall project beyond each side of the structural member.

ROCK WOOL MANUFACTURING CO — Delta Deck Plugs

B. **Forming Material\*** — Min 3 in. thick min 4 pcf (64 kg/m<sup>3</sup>) mineral wool batt insulation cut to the width of the ceiling runner and compressed 50 percent in thickness, installed into ceiling runner between leg of track and gypsum liner board.

INDUSTRIAL INSULATION GROUP L L C — MinWool-1200 Safing

JOHNS MANVILLE — Safing

ROCK WOOL MANUFACTURING CO — Delta Safing Board

ROCKWOOL MALAYSIA SDN BHD — SAFE

ROCKWOOL — SAFE

THERMAFIBER INC — SAF

C. **Fill, Void or Cavity Material\*** — Nom 20 ga U-shaped track having 3 in (76 mm) legs with a nom 1-1/4 in. (32 mm) wide intumescent strip affixed to the top of one leg overlapping on to top surface a min of 1/4 in. (6 mm). Track to be secured to steel attachment clips with min No 8 by 1/2 in. (13 mm) long steel fasteners spaced at a max of 16 in. (406 mm) OC (min one fastener into each clip).

CALIFORNIA EXPANDED METAL PRODUCTS CO — FAS Shaft Track

C1. **Fill, Void or Cavity Material\*** — (Not Shown) as an alternate to 3C a min. 25 ga composite steel angle with one 5/8 in. (16 mm) leg and one 2-1/2 in (64 mm) leg with a 5/8 in. (16 mm) strip of intumescent strip affixed along the inside 2-1/2 in (64 mm) leg. The 5/8 in.(16 mm) leg is friction fit between the top web of the ceiling runner and Item 1D steel attachment clips on the finish side only.

CALIFORNIA EXPANDED METAL PRODUCTS CO — DDA (Deflection Drift Angle)

C2. **Fill, Void or Cavity Material\*** — As an option to item C.1 a min 25 ga composite steel angle with one 5/8 in. (16 mm) leg and one 1-1/4 in (32 mm) leg with a strip of intumescent strip affixed along the inside 1-1/4 in (32 mm) leg. Steel angle is friction fit between the top web of the ceiling runner and the concrete deck.

CALIFORNIA EXPANDED METAL PRODUCTS CO — DDA-1 (Deflection Drift Angle)

C3. **Fill, Void or Cavity Material\*** — As an alternate to Item 3C Nom 20ga J-shaped track having a one 1-1/2 in. solid leg and one 2-1/2 in. leg nom 1/2 in. (13 mm) wide intumescent strip affixed to the top outer web along the outside corner facing the finish side of the wall. Track to be secured to bottom side of floor assembly with steel masonry or powder actuated fasteners spaced at a max of 24 in. (610 mm) OC.

CALIFORNIA EXPANDED METAL PRODUCTS CO — Fire Rated J-Track

UNITED STATES GYPSUM CO — USG Sheetrock® Brand Firecode® J-Runner

MARINO/WARE, DIV OF WARE INDUSTRIES INC — Fire Rated J-Track

D. **Fill, Void or Cavity Material\* — Sealant** — (Not Shown) -Sealant may be used to seal any gaps at end joints between ceiling runners, and gaps above ceiling runner, to maintain L Ratings.

### Configuration D (Not shown, 1 in. version of C)

3. **Joint System** — Max separation between floor or roof deck or bottom of spray-applied fire resistive material on steel floor or roof unit and top of wall (at time of installation of joint system) is 1 in. (16 mm). The joint system is designed to accommodate a max 100 percent compression or extension from its installed width. When Item 2A. 1 is used the nominal joint width is max to 3/4 in. (19 mm).

A. **Forming Material\*** — Min 4 pcf (64 kg/m<sup>3</sup>) mineral wool insulation cut to the shape of the fluted steel floor or roof deck units, approx 33% larger than the area of the flutes. Pieces compressed and inserted into and completely filling the flutes above the structural support member. As an option, the spray-applied fire resistive material described in Item 1 can be used in place of the packing material.

INDUSTRIAL INSULATION GROUP L L C — MinWool-1200 Safing

JOHNS MANVILLE — Safing

ROCK WOOL MANUFACTURING CO — Delta Safing Board

ROCKWOOL MALAYSIA SDN BHD — SAFE

ROCKWOOL — SAFE

THERMAFIBER INC — SAF

A1. **Forming Material\* - Plugs** — (Not Shown) — As an alternate to the forming material (Item 3A), mineral wool plugs preformed to the shape of the fluted floor units, may be used within the flutes. Plugs shall be friction fit to completely fill the flutes above the structural member. The plugs shall project beyond each side of the structural member.

ROCK WOOL MANUFACTURING CO — Delta Deck Plugs

B. **Forming Material\*** — Min 3 in. thick min 4 pcf (64 kg/m<sup>3</sup>) mineral wool batt insulation cut to the width of the ceiling runner and compressed 50 percent in thickness, installed into ceiling runner between leg of track and gypsum liner board.

INDUSTRIAL INSULATION GROUP L L C — MinWool-1200 Safing

JOHNS MANVILLE — Safing

ROCK WOOL MANUFACTURING CO — Delta Safing Board

ROCKWOOL MALAYSIA SDN BHD — SAFE

ROCKWOOL — SAFE

THERMAFIBER INC — SAF

C. **Fill, Void or Cavity Material\*** — Nom 20 ga U-shaped track having 3 in (76 mm) legs with a nom 2-1/2 in. (64 mm) wide intumescent strip affixed to the top of each leg overlapping on to top surface a min of 1/4 in. (6 mm). Track to be secured to steel attachment clips with min No 8 by 1/2 in. (13 mm) long steel fasteners spaced at a max of 16 in. (406 mm) OC (min one fastener into each clip).

CALIFORNIA EXPANDED METAL PRODUCTS CO — FAS Shaft Track DL2

C1. **Fill, Void or Cavity Material\*** — (Not Shown) as an alternate to 3C a min. 25 ga composite steel angle with one 5/8 in. (16 mm) leg and one 2-1/2 in (64 mm) leg with a 5/8 in. (16 mm) strip of intumescent strip affixed along the inside 2-1/2 in (64 mm) leg. The 5/8 in.(16 mm) leg is friction fit between the top web of the ceiling runner and Item 1D steel attachment clips on the finish side only.

CALIFORNIA EXPANDED METAL PRODUCTS CO — DDA (Deflection Drift Angle)

D. **Fill, Void or Cavity Material\* — Sealant** — (Optional, Not Shown) -Sealant may be used to seal any gaps at end joints between ceiling runners, and gaps above ceiling runner, to maintain L Ratings.

RECTORSEAL — Metacaulk 1200, Biostop 750, FlameSafe FS3000, Metacaulk 1500, or Biostop 800 Spray.

\* Indicates such products shall bear the UL or cUL Certification Mark for jurisdictions employing the UL or cUL Certification (such as Canada), respectively.

The appearance of a company's name or product in this database does not in itself assure that products so identified have been manufactured under UL's Follow-Up Service. Only those products bearing the UL Mark should be considered to be Certified and covered under UL's Follow-Up Service. Always look for the Mark on the product.

UL permits the reproduction of the material contained in the Online Certification Directory subject to the following conditions: 1. The Guide Information, Assemblies, Constructions, Designs, Systems, and/or Certifications (files) must be presented in their entirety and in a non-misleading manner, without any manipulation of the data (or drawings). 2. The statement "Reprinted from the Online Certifications Directory with permission from UL" must appear adjacent to the extracted material. In addition, the reprinted material must include a copyright notice in the following format: "© 2022 UL LLC"