

## XHBN.HW-D-0652 - Joint Systems

Design/System/Construction/Assembly Usage Disclaimer

- Authorities Having Jurisdiction should be consulted in all cases as to the particular requirements covering the installation and use of UL Certified products, equipment, system, devices, and materials.
- Authorities Having Jurisdiction should be consulted before construction.
- Fire resistance assemblies and products are developed by the design submitter and have been investigated by UL for compliance with applicable requirements. The published information cannot always address every construction nuance encountered in the field.
- When field issues arise, it is recommended the first contact for assistance be the technical service staff provided by the product manufacturer noted for the design. Users of fire resistance assemblies are advised to consult the general Guide Information for each product category and each group of assemblies. The Guide Information includes specifics concerning alternate materials and alternate methods of construction.
- Only products which bear UL's Mark are considered Certified.

## XHBN - Joint Systems

### XHBN7 - Joint Systems Certified for Canada

[See General Information for Joint Systems](#)

[See General Information for Joint Systems Certified for Canada](#)

#### System No. HW-D-0652

June 08, 2020

| ANSI/UL2079  | CAN/ULC S115  |
|--|---|
| Assembly Ratings — 1 and 2 Hr (See Item 2)   | F Ratings — 1 and 2 Hr (See Item 2)   |
| Nominal Joint Width — 3/8, 1/4, 1/2, 3/4, 1, 1-1/2 In.   | FT Ratings — 1 and 2 Hr (See Item 2)  |
| Class II or III Movement Capabilities — 80% Compression and or 30% Extension or 80% compression only. or 100% Compression and Extension (See Item 3) | FH Ratings — 1 and 2 Hr (See Item 2)  |
| L Rating At Ambient — Less Than 1 CFM/Lin Ft.  | FTH Ratings — 1 and 2 Hr (See Item 2)   |
| L Rating At 400°F — Less Than 1 CFM/Lin Ft   | Nominal Joint Width — 6, 10, 13, 19, 25, 38 mm  |
| The Air leakage Rating Does not apply if item 1E.1 is used.  | Class II or III Movement Capabilities — 80% Compression and or 30% Extension or 80% compression only or 100% Compression and Extension (See Item 3) |
|  | L Rating At Ambient — Less Than 1.55 L/s/m  |
|  | L Rating At 203°C — 1.55 L/s/m  |
|  | The Air leakage Rating Does not apply if item 1E.1 is used.   |

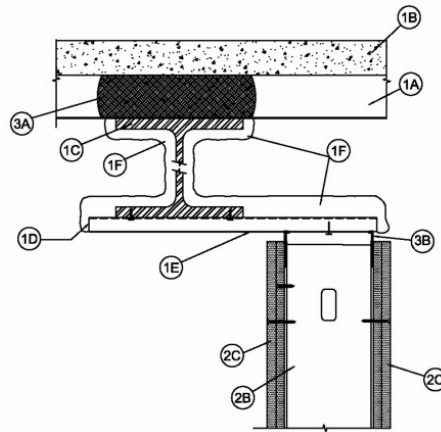

conFig C

**1. Floor Assembly** — The fire-rated fluted steel deck/concrete floor assembly shall be constructed of the materials and in the manner described in the individual D700 or D900 Series Floor-Ceiling Design in the UL Fire Resistance Directory and shall include the following construction features:

**A. Steel Floor And Floor Units\*** — Max 3 in. (76 mm) deep galv steel fluted floor units.

**B. Concrete** — Min 2-1/2 in. (64 mm) thick reinforced concrete, as measured from the top plane of the floor units.

**C. Structural Steel Support** — Steel beam, as specified in the individual D700 or D900 Series Floor-Ceiling Design, used to support steel floor units. Structural steel support oriented parallel to and 8 in. (203 mm) max from wall assembly.

**D. Steel Attachment Clips** — 1 in. (25 mm) wide Z-shaped clips or channels formed from min 20 ga galv or painted steel. Clips to be sized to extend through the thickness of the spray-applied fire-resistive material on the bottom flange of the steel beam with 1-1/2 in. (38 mm) long upper and lower legs. Legs of clips fastened to bottom of beam (prior to application of spray-applied fire-resistive materials) with steel fasteners or welds and to ceiling runner of wall with bolts or screws. Clips spaced max 16 in. (406 mm) OC and extend from steel support beam to flush with non-beam face of wall.

**E. Steel Plate** — Min 22 Ga sheet steel shall be installed under and attached to the steel attachment clips or channels (Item 1D) to completely cover the exposed area from the flange tip of the steel beam to the framed wall surface. The plate shall be secured with steel fasteners or welds and shall be covered with spray applied fire resistive material (see Item 1F).

**E1. Steel Lath** — (Not Shown) As an alternate to 1E above. Nom 3/8 in. (10 mm) diamond mesh expanded steel rib lath having a nom weight of 3.4 lb/yd<sup>2</sup> (1.8 kg/m<sup>2</sup>) shall be installed over and attached to the steel attachment clip bars or channels (Item 1D) to completely cover the exposed area from the flange tip of the steel beam to the end of the bar/channel framing extending beyond the wall surface. The lath shall be secured with steel fasteners or tie wire and shall be fully covered with spray applied fire resistive material (Item 1F).

**F. Spray-Applied Fire Resistive Material\*** — After installation of the steel attachment clips, steel plate, angle, ceiling runners, structural steel support, and steel floor units (as applicable), to be sprayed with the min thickness of material specified in the individual D700 or D900 Series Design. Each steel attachment clip is to be fully covered with spray applied fire resistive material to the minimum thickness of material required on the flanges of the steel beam. The spaces between the clips and above and below the steel lath (Item 1E.1) shall also be fully filled from beam and over the entire thickness of the wall. The spaces between the clips and above and below the steel lath (Item 1E.1) shall also be fully filled from beam and over the entire thickness of the wall. Additional material shall be applied to the web of steel beam on each side of wall. The min total thickness of material applied to each side of steel beam web shall be 13/16 in. (21 mm) for 1 hr Assembly Rating and 1-1/2 in. (38 mm) for 2 hr Assembly Rating. When Item 3A is not used, the flutes of the steel floor units are to be filled with material across the entire top flange of the steel beam. For D700 floors, the remainder of the steel floor units shall be sprayed as specified in the individual D700 design.

**ISOLATEK INTERNATIONAL** — Type 300

**GCP APPLIED TECHNOLOGIES INC** — Type MK-6/HY

**1A. Roof Assembly** — (Not Shown) — As an alternate to the floor assembly, a fire-rated fluted steel deck roof assembly may be used. The roof assembly shall be constructed of the materials and in the manner described in the individual P700 or P900 Series Roof-Ceiling Design in the UL Fire Resistance Directory. The roof assembly shall include the following construction features:

**A. Steel Roof Deck** — Max 3 in. (76 mm) deep galv steel fluted roof deck.

**B. Roof Insulation** — Min 2-1/4 in. (57 mm) thick poured insulating concrete, as measured from the top plane of the roof deck.

**C. Structural Steel Support** — Steel beam, as specified in the individual P700 or P900 Series Design, used to support steel floor units. Structural steel support oriented parallel to and 8 in. (203 mm) max from wall assembly.

**D. Steel Attachment Clips** — 1 in. (25 mm) wide Z-shaped clips or channels formed from min 20 ga galv or painted steel. Clips to be sized to extend through the thickness of the spray-applied fire-resistive material on the bottom flange of the steel beam with 1-1/2 in. (38 mm) long upper and lower legs. Legs of clips fastened to bottom of beam (prior to application of spray-applied fire-resistive materials) with steel fasteners or welds and to ceiling runner of wall with bolts or screws. Clips spaced max 16 in. (406 mm) OC and extend from steel support beam to flush with non-beam face of wall.

**E. Steel Plate** — Min 22 Ga sheet steel shall be installed under and attached to the steel attachment clips or channels (Item 1D) to completely cover the exposed area from the flange tip of the steel beam to the framed wall surface. The plate shall be secured with steel fasteners or welds and shall be covered with spray applied fire resistive material (see Item 1F).

E1. **Steel Lath** — (Not shown) As an alternate to 1E above. Nom 3/8 in. (10 mm) diamond mesh expanded steel rib lath having a nom weight of 3.4 lb/yd<sup>2</sup> (1.8 kg/m<sup>2</sup>) shall be installed over and attached to the steel attachment clip bars or channels (Item 1D) to completely cover the exposed area from the flange tip of the steel beam to the end of the bar/channel framing extending beyond the wall surface. The lath shall be secured with steel fasteners or tie wire and shall be fully covered with spray applied fire resistive material (Item 1F).

F. **Spray-Applied Fire Resistive Material\*** — After installation of the steel attachment clips, steel plate, angles, ceiling runners, structural steel support, and roof deck (as applicable), to be sprayed with the min thickness of material specified in the individual P700 or P900 Series Design. Each steel attachment clip is to be fully covered with spray applied fire resistive material to the minimum thickness of material required on the flanges of the steel beam. The spaces between the clips and above steel plate (Item 1E) shall also be fully filled from beam and over the entire thickness of the wall. The spaces between the clips and above and below the steel lath (Item 1E, 1) shall also be fully filled from beam and over the entire thickness of the wall. Additional material shall be applied to the web of steel beam on each side. The min total thickness of material applied to each side of steel beam web shall be 13/16 in. (21 mm) for 1 hr Assembly Rating and 1-1/2 in. (38 mm) for 2 hr Assembly Rating. When Item 3A is not used, the flutes of the roof deck are to be filled with material across the entire top flange of the steel beam. For P700 roof-ceiling assemblies, the remainder of the roof deck shall be sprayed as specified in the individual P700 design.

**ISOLATEK INTERNATIONAL** — Type 300

**GCP APPLIED TECHNOLOGIES INC** — Type MK-6/HY

18. **Floor Assembly — (Not Shown)** — Min 4-1/2 in. thick reinforced lightweight or normal weight (100 to 150 pcf) structural concrete

2. **Wall Assembly** — The 1 or 2 hr fire rated gypsum board/stud wall assembly shall be constructed of the materials and in the manner described in the individual U400 or V400 Series Wall and Partition Design in the UL Fire Resistance Directory and shall include the following construction features:

A. **Steel Floor and Ceiling Runners** — Floor runner U-shaped, sized to accommodate steel studs (Item 2B), fabricated from 20 ga galv steel. Runners attached to steel attachment clips through steel plate (Item 1E) with min 2 in. (51 mm) long steel fasteners, minimum one fastener per clip. The ceiling runners are provided with a fill, void or cavity material on both legs of runner and are described in Item 3. Legs are to be min 1/4 in. (6 mm) longer than the maximum joint width. Ceiling runner to be installed parallel with structural steel support and located such that a max clearance of 8 in. (203 mm) is present between the finished wall and the flange of the steel beam (Item 1C).

A.1. **Light Gauge Framing\* — Slotted Ceiling Track** — (Not Shown) - As an alternate to the Item 2A, a ceiling track consisting of galv steel channel with slotted flanges may be used when Configuration C and Item 3B.2 or configuration D Item 3B.1 fill material is utilized. Slotted ceiling track sized to accommodate steel studs (Item 2B). Legs are to be min 1/4 in. (6 mm) longer than the maximum joint width. Attached to steel deck with steel fasteners or welds spaced max 24 in. (610 mm) OC.

**BRADY CONSTRUCTION INNOVATIONS INC, DBA SLIPTRACK SYSTEMS** — SLP-TRK

**CALIFORNIA EXPANDED METAL PRODUCTS CO** — CST, CST 325

**MARINO/WARE, DIV OF WARE INDUSTRIES INC** — Type SLT

B. **Studs** — Steel studs to be min 3-5/8 in. (92 mm) wide. Studs cut 5/8 to 1-1/4 in. (16 to 32 mm) less in length than assembly height with bottom nesting in and secured to floor runner. Steel studs secured to slotted ceiling runner with No. 8 by 1/2 in. (13 mm) long wafer head steel screws at mid-height of exposed slot. Studs spaced max 24 in. (610 mm) OC.

C. **Gypsum Board\*** — Gypsum board 1/2 or 5/8 in. (13 or 16 mm) thick, applied on both sides of wall as specified in the individual Wall and Partition Design except that a max 5/8 in. (16 mm) gap shall be maintained between the top of the gypsum board and the bottom of the floor-ceiling assembly. The screws attaching the gypsum board layer(s) to the studs shall be located 4 to 5 in. (102 to 127 mm) down from deck at time of installation. No gypsum board attachment screws shall be driven into the ceiling runner.

**The hourly rating of the joint system is equal to the hourly fire rating of the wall.**

3. **Joint System — Max separation between floor or roof deck or bottom of spray-applied fire resistive material on steel floor or roof unit and top of wall (at time of installation of joint system) is 5/8 in. (16 mm). When Item 3B.2 is used the nominal width is 1/2 in. (13 mm) or max 3/4 in. (19 mm), when Item 3B.3 is used the max nominal joint with is 3/8 in. (10 mm). The joint system is designed to accommodate a max 80 percent compression and or 30 percent extension from its installed width of 5/8 or less, or 80% compression only when joint is installed at 3/4 in (19 mm). When Item 3A4 is used the joint will accommodate 100 percent compression and extension from nominal 3/8 in. (10 mm) installed width.** When Item 3B8 is used the joint will accommodate 100 % compression/extension for nominal 1/2 in. (12 mm) gaps or compression only for nominal 1 in. (25 mm) gaps. When Item 3B9 is used the joint will accommodate 100% compression/ extension for nominal 3/4 in. (19 mm) gaps or compression only for 1-1/2 in. (38 mm) gaps. When item 3B9 is used the joint will accommodate 100% compression/extension for nominal 1/4 in. (6mm) gaps or compression only for 1/2 in. (12mm) gaps.

A. **Forming Material\*** — Min 4 pcf (64 kg/m<sup>3</sup>) mineral wool insulation cut to the shape of the fluted steel floor or roof deck units, approx 33% larger than the area of the flutes. Pieces compressed and inserted into and completely filling the flutes above the structural support member. As an option, the spray-applied fire resistive material described in Item 1 can be used in place of the packing material.

B1. **Fill, Void or Cavity Material\*** — (Not Shown) as an alternate to 3B a min. 25 ga composite steel angle with one 5/8 in. (16 mm) leg and one 2-1/2 in (64 mm) leg with a 5/8 in. (16 mm) strip of intumescent strip affixed along the inside 2-1/2 in (64 mm) leg. 5/8 in. (16 mm) leg of steel angle is friction fit between the top web of the ceiling runner and Item 1D steel attachment clips.

**CALIFORNIA EXPANDED METAL PRODUCTS CO** — DDA (Deflection Drift Angle)

B2. **Fill, Void or Cavity Material\*** — As an option to item 3A a min 25 ga composite steel angle with one 5/8 in. (16 mm) leg and one 1-1/4 in (32 mm) leg with a strip of intumescent strip affixed along the inside 1-1/4 in (32 mm) leg. Steel angle is friction fit between the top web of the ceiling runner and the concrete deck.

**CALIFORNIA EXPANDED METAL PRODUCTS CO** — DDA-1 (Deflection Drift Angle)

B3. **Fill, Void or Cavity Material\*** — In lieu of item 3B - Min 20 ga steel channel track with 2, or 2-3/4 in. (51, or 70 mm) legs with or without slots having nom 1/2 in. (13 mm) wide intumescent strips affixed to the top web along the outer corner on both sides and sized to accommodate steel studs. Track attached to steel attachment clips with min No 8 by 1/2 in. (13 mm) long steel fasteners spaced at a max of 16 in. (406 mm) OC (min one fastener into each clip).

**CALIFORNIA EXPANDED METAL PRODUCTS CO** — FAS Track 1000, FAS Track 1000DL

**MARINO/WARE, DIV OF WARE INDUSTRIES INC** — FAS Track 1000, FAS Track 1000DL

B4. **Fill, Void or Cavity Material\*** — (Not Shown) - As an alternate for items 3B1, 3B2, 3B3, and 3B4 for nominal 3/4 in. (19 mm) gap 80% compression and 30% extension between the edge of the drywall and the floor/ceiling assembly shall be filled with vinyl deflection bead with 5/16 in. (8 mm) intumescent strip and foam applied to horizontal leg that runs above the edge of the drywall. The perforated leg may be attached to the surface of the drywall with 1/2 in. (13 mm) staples every 6-8 in. (152-203 mm).

**CALIFORNIA EXPANDED METAL PRODUCTS CO** — HOTROD XL

**MARINO/WARE, DIV OF WARE INDUSTRIES INC** — HOTROD XL

B5. **Fill, Void or Cavity Material\*** — (Not Shown) - As an alternate for items 3B1, 3B2, 3B3, and 3B4 for nominal joint 3/4 in. (19 mm) 80% compression and 30% extension. Nominal 1 in. (25.4 mm) open cell foam plug having a nominal 5/16 in. (8 mm) intumescent tape applied to the top surface of the foam profile. The foam is sized for 1 or 2 hour walls and shall be placed in the joint above the top edge of the drywall between the concrete slab. A layer of tape and joint compound can then be applied over the HOTROD Type X assembly.

**CALIFORNIA EXPANDED METAL PRODUCTS CO** — HOTROD Type-X

B6. **Fill, Void or Cavity Material\*** — (Not Shown) - As an alternate for items 3B1, 3B2, 3B3, and 3B4 for 1/2 in. (13 mm) nominal gap 75% compression and 25% extension 1 in. (25.4 mm) open cell foam plug having a nom 5/16 in. (8 mm) intumescent tape applied to the top surface of the foam profile. The foam is sized for 1 or 2 hour walls and shall be placed in the joint above the top edge of the drywall between the floor/ceiling assembly.

**CALIFORNIA EXPANDED METAL PRODUCTS CO** — HOTROD Type-X

B7. **Fill, Void or Cavity Material\*** — (Not Shown) - For nominal 1/2 in. (12 mm) gaps 100% compression/ extension or 1 in. (25 mm) compression only. As an alternate to DDA-1 (Item B2) a composite corrugated vinyl profile with a 1-1/2 in. (38 mm) wide leg and a 3/8 in. (10 mm) bubble gasket along the upper edge. A 5/8 in. (16 mm) wide intumescent strip affixed along the inside 1-1/2 in. (38 mm) leg. Composite vinyl profile is attached to the leg of the ceiling runner/track with 1/2 in. (13 mm) No. 8 framing screws or adhesively attached with double sided foam tape.

**CALIFORNIA EXPANDED METAL PRODUCTS CO** — Fire Gasket 1

**MARINO/WARE, DIV OF WARE INDUSTRIES INC** — Fire Gasket 1

**TRIM-TEX INC** — Trim Tex-Fire Gasket 1

B8. **Fill, Void or Cavity Material\*** — (Not Shown) - For nominal 3/4 in. (19 mm) gaps 100% compression/extension or 1-1/2 in. (38 mm) compression only. As an alternate to DDA-1 (Item B2) a composite corrugated vinyl profile with a 2 in. (50 mm) wide leg and a 3/8 in. (10 mm) bubble gasket along the upper edge. A 1 in. (25 mm) wide intumescent strip affixed along the inside 1-1/2 in. (38 mm) leg. Composite vinyl profile is attached to the leg of the ceiling runner/track with 1/2 in. (13 mm) No. 8 framing screws or adhesively attached with double sided foam tape.

**CALIFORNIA EXPANDED METAL PRODUCTS CO** — Fire Gasket 1.5

**MARINO/WARE, DIV OF WARE INDUSTRIES INC** — Fire Gasket 1.5

**TRIM-TEX INC** — Trim Tex-Fire Gasket 1.5

B9. **Fill, Void or Cavity Material\*** — (Not Shown) - For nominal 1/4 in. (6mm) gaps 100% compression/ extension or 1/2 in. (12mm) compression only. As an alternate to DDA-1 (Item A2) a composite corrugated vinyl profile with a 1-1/8 in. (28 mm) wide leg and a 1/4 in. (6 mm) bubble gasket along the upper edge. A 1/4 in. (6 mm) wide intumescent strip affixed along the inside 1-1/8 in. (28 mm) leg. Composite vinyl profile is attached to the leg of the ceiling runner/track with 1/2 in. (12 mm) No. 8 framing screws or adhesively attached with double sided foam tape.

**CALIFORNIA EXPANDED METAL PRODUCTS CO** — Fire Gasket 0.5

C. **Fill, Void or Cavity Material\* — Sealant** — (Optional, Not Shown) -Sealant may be used to seal any gaps at end joints between ceiling runners, and gaps above ceiling runner, to attain L Ratings.

**HILTI CONSTRUCTION CHEMICALS, DIV OF HILTI INC** — CP672 Firestop Spray or CFS-SP WB. Firestop Joint Spray

D. **Packing Material** — (Not Shown) - When item 3B.1, 3B.2, or 3B.3 is used, continuous length of open cell polyurethane foam with a nominal diameter of 1/8 in. (3.2 mm) greater than the max width of the joint. The foam shall have a nominal density of 1.7 pcf. The foam is to be placed in the joint above the top edge of the drywall between the beam. Any splices are to be tightly butted. A layer of tape and joint compound can then be applied over the open cell foam.

**\* Indicates such products shall bear the UL or cUL Certification Mark for jurisdictions employing the UL or cUL Certification (such as Canada), respectively.**

[Last Updated](#) on 2020-06-08

---

The appearance of a company's name or product in this database does not in itself assure that products so identified have been manufactured under UL's Follow-Up Service. Only those products bearing the UL Mark should be considered to be Certified and covered under UL's Follow-Up Service. Always look for the Mark on the product.

UL permits the reproduction of the material contained in the Online Certification Directory subject to the following conditions: 1. The Guide Information, Assemblies, Constructions, Designs, Systems, and/or Certifications (files) must be presented in their entirety and in a non-misleading manner, without any manipulation of the data (or drawings). 2. The statement "Reprinted from the Online Certifications Directory with permission from UL" must appear adjacent to the extracted material. In addition, the reprinted material must include a copyright notice in the following format: "© 2022 UL LLC"