

XHBN.HW-D-0606 - Joint Systems

Design/System/Construction/Assembly Usage Disclaimer

- Authorities Having Jurisdiction should be consulted in all cases as to the particular requirements covering the installation and use of UL Certified products, equipment, system, devices, and materials.
- Authorities Having Jurisdiction should be consulted before construction.
- Fire resistance assemblies and products are developed by the design submitter and have been investigated by UL for compliance with applicable requirements. The published information cannot always address every construction nuance encountered in the field.
- When field issues arise, it is recommended the first contact for assistance be the technical service staff provided by the product manufacturer noted for the design. Users of fire resistance assemblies are advised to consult the general Guide Information for each product category and each group of assemblies. The Guide Information includes specifics concerning alternate materials and alternate methods of construction.
- Only products which bear UL's Mark are considered Certified.

XHBN - Joint Systems

System No. HW-D-0606

September 26, 2019

Assembly Ratings — 1 and 2 Hr (See Items 1 and 4C)

Nominal Joint Width — 3/4 in.

L Rating At Ambient — Less Than 1 CFM/Lin Ft

L Rating At 400°F — Less Than 1 CFM/Lin Ft

Class II Movement Capabilities — 25% Compression

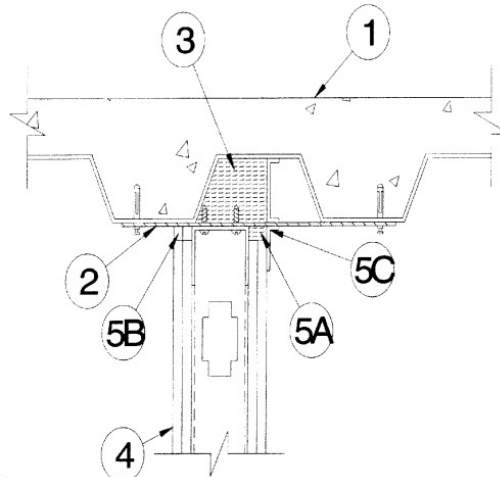

1. **Floor Assembly** — The fire-rated fluted steel floor unit/concrete floor assembly shall be constructed of the materials and in the manner described in the individual Floor-Ceiling Design in the Fire Resistance Directory and shall include the following construction features:

A. **Steel Floor and Form Units*** — Max 3 in. (76 mm) deep galv steel fluted floor units.

B. **Concrete** — Min 2-1/2 in. (64 mm) thick reinforced concrete, as measured from the top plane of the floor units.

2. **Steel Straps** — Min 2 in. (51 mm) wide min No. 16 gauge (1.5 mm thick) galv steel straps cut to a length to span the flute and overlap the adjacent valleys of fluted floor units by min 1-1/2 in. (38 mm). Straps spaced max 24 in. (610 mm) OC and fastened to floor assembly with masonry anchors or steel fastener.

3. **Forming Material*** — Mineral wool plugs, formed to the shape of the fluted floor area directly above the wall, friction fit to fill the fluted area directly above the steel straps and wall. Adjacent lengths of plugs to be tightly butted with butted seams spaced min 24 in. (610 mm) apart along the length of the plugs.

INDUSTRIAL INSULATION GROUP L L C — MinWool-1200 Safing

ROCK WOOL MANUFACTURING CO — Delta Board

ROCKWOOL MALAYSIA SDN BHD — Safe

ROCKWOOL — Safe

THERMAFIBER INC — SAF

4. **Wall Assembly** — The 1 or 2 h fire-rated gypsum board/stud wall assembly shall be constructed of the materials and in the manner specified in the individual U400 or V400 Series Wall and Partition Design in the UL Fire Resistance Directory and shall include the following construction features:

A. **Steel Floor and Ceiling Runners** — Floor and ceiling runners of wall assembly shall consist of min No. 25 gauge galv steel channels sized to accommodate steel studs (Item 2B). Flange height of ceiling runner shall be min 1/4 in. (6 mm) greater than max extended joint width. Ceiling runner installed parallel to direction of fluted steel floor units, directly beneath steel straps, and secured to straps with two No. 8 self-drilling, self-tapping steel screws per strap.

A1. **Light Gauge Framing*** — Slotted Ceiling Runner — Slotted ceiling runner may be used as an alternate to the ceiling runner in Item 3A. Slotted ceiling runner to consist of galv steel channel with slotted flanges sized to accommodate steel studs (Item 3B). Ceiling runner installed perpendicular to direction of fluted steel floor or roof deck and secured to valleys with steel masonry anchors spaced max 24 in. (610 mm) OC. When slotted ceiling runner is used, deflection channel (Item 4A) shall not be used.

BRADY CONSTRUCTION INNOVATIONS INC, DBA SLIPTRACK SYSTEMS — SLP-TRK

CALIFORNIA EXPANDED METAL PRODUCTS CO — CST

CLARKDIETRICH BUILDING SYSTEMS — Type SLT, SLT-H

METAL-LITE INC — The System

SCAFCO STEEL STUD MANUFACTURING CO

A2. **Light Gauge Framing*** — Vertical Deflection Ceiling Runner — When the nom joint width is less than or equal to 1 in. (25 mm), vertical deflection ceiling runner may be used as an alternate to the ceiling runner in Items 3A and 3A1. Vertical deflection ceiling runner to consist of galv steel channel with slotted vertical deflection clips mechanically fastened within runner. Slotted clips, provided with step bushings, for permanent fastening of steel studs. Vertical deflection ceiling runner installed perpendicular to direction of fluted steel deck and secured to valleys with steel masonry anchors spaced max 24 in. (610 mm) OC. When vertical deflection ceiling runner is used, deflection channel (Item 4A) shall not be used.

A3. **Light Gauge Framing*** — Clipped Ceiling Runner — As an alternate to the ceiling runner in Items 3A and 3A1, clipped runner to consist of galv steel channel with clips preformed in track flanges which positively engage the inside flange of the steel studs (Item 3B). Track sized to accommodate steel studs (Item 3B). Track flanges to be min 2-3/4 in. (70 mm). Clipped ceiling runner installed perpendicular to direction of fluted steel deck and secured to valleys with steel masonry anchors spaced max 12 in. (305 mm) OC. When clipped ceiling runner is used, deflection channel (Item 4A) shall not be used.

TOTAL STEEL SOLUTIONS L L C — Snap Trak

A4. **Light Gauge Framing*** — Notched Ceiling Runner — As an alternate to the ceiling runners in Items 3A through 3A3, notched ceiling runners to consist of C-shaped galv steel channel with notched return flanges sized to accommodate steel studs (Item 3B). Notched ceiling runner installed perpendicular to direction of fluted steel deck and secured to valleys with steel masonry anchors spaced max 24 in. (610 mm) OC. When notched ceiling runner is used, deflection channel (Item 4A) shall not be used.

OLMAR SUPPLY INC — Type SCR

B. **Studs** — Steel studs to be min 3-1/2 in. (89 mm) wide. Studs cut 1/2 to 3/4 in. (13 to 19 mm) less in length than assembly height with bottom nesting in and resting on the floor runner and with top nesting in ceiling runner without attachment. When slotted ceiling runner (Item 4A1) is used, steel studs secured to slotted ceiling runner with No. 8 by 1/2 in. (13 mm) long wafer head steel screws at midheight of slot on each side of wall. Stud spacing not to exceed 24 in. (610 mm) OC.

C. **Gypsum Board*** — For 1 hr assembly, one layer of 5/8 in. (16 mm) thick gypsum board as specified in the individual Wall and Partition Design. For 2 hr assembly, two layers of 5/8 in. (16 mm) thick gypsum board as specified in the individual Wall and Partition Design. For both hourly ratings, a nominal 3/4 in. (19 mm) gap shall be maintained between the top of the gypsum board and the bottom surface of the steel floor units and the bottom surface of the steel straps and forming material (Item 3). The top row of screws shall be installed into the studs 3 in. (76 mm) below the valleys of the steel floor units.

5. **Joint System** — Max separation between bottom of floor or roof deck and top of gypsum board (at time of installation of joint system) is 3/4 in. (19 mm). The joint system is designed to accommodate a max 25 percent compression from its installed width. The joint system shall consist of forming and fill materials as follows:

A. **Forming Material*** — Min 4 pcf (64 kg/m³) density mineral wool batt insulation shall be cut into strips to fill the gap between the top of the gypsum board and the underside of the forming material plugs (Item 3) and straps (Item 2) on the side of the wall located beneath the crest of the floor units. The width of the strips shall be equal to the total thickness of the gypsum board. The strips of mineral wool are compressed 50 percent in thickness and inserted cut-edge first into the gap between the top of the gypsum board and bottom of the mineral wool plug or steel straps.

INDUSTRIAL INSULATION GROUP L L C — MinWool-1200 Safing

ROCK WOOL MANUFACTURING CO — Delta Board

ROCKWOOL MALAYSIA SDN BHD — Safe

ROCKWOOL — Safe

THERMAFIBER INC — SAF

B. **Fill, Void or Cavity Material*** — Sealant — Min 1/2 in. (13 mm) thickness of fill material installed on the side of the wall located beneath valley of steel floor units, between the top of the gypsum board and the bottom of the valleys of the steel floor units, flush with the face of the wall.

SPECIFIED TECHNOLOGIES INC — SpecSeal ES Elastomeric Sealant or SpecSeal LC150 Sealant

C. **Fill, Void or Cavity Material*** — Min 1/8 in. (3.2 mm) wet thickness (min 1/16 in. or 1.6 mm dry thickness) of fill material sprayed or brushed to completely cover the mineral wool plugs (Item 3) and mineral wool forming material (Items 5A and 5A1) on the side of the wall located beneath the crest of the steel floor unit. Fill material to overlap a min of 1/2 in. (13 mm) onto the gypsum board, steel floor units and steel straps.

SPECIFIED TECHNOLOGIES INC — SpecSeal AS200 Elastomeric Spray

*** Indicates such products shall bear the UL or cUL Certification Mark for jurisdictions employing the UL or cUL Certification (such as Canada), respectively.**

[Last Updated](#) on 2019-09-26

The appearance of a company's name or product in this database does not in itself assure that products so identified have been manufactured under UL's Follow-Up Service. Only those products bearing the UL Mark should be considered to be Certified and covered under UL's Follow-Up Service. Always look for the Mark on the product.

UL permits the reproduction of the material contained in the Online Certification Directory subject to the following conditions: 1. The Guide Information, Assemblies, Constructions, Designs, Systems, and/or Certifications (files) must be presented in their entirety and in a non-misleading manner, without any manipulation of the data (or drawings). 2. The statement "Reprinted from the Online Certifications Directory with permission from UL" must appear adjacent to the extracted material. In addition, the reprinted material must include a copyright notice in the following format: "© 2022 UL LLC"