

XHBN.HW-D-0585 - Joint Systems

Design/System/Construction/Assembly Usage Disclaimer

- Authorities Having Jurisdiction should be consulted in all cases as to the particular requirements covering the installation and use of UL Certified products, equipment, system, devices, and materials.
- Authorities Having Jurisdiction should be consulted before construction.
- Fire resistance assemblies and products are developed by the design submitter and have been investigated by UL for compliance with applicable requirements. The published information cannot always address every construction nuance encountered in the field.
- When field issues arise, it is recommended the first contact for assistance be the technical service staff provided by the product manufacturer noted for the design. Users of fire resistance assemblies are advised to consult the general Guide Information for each product category and each group of assemblies. The Guide Information includes specifics concerning alternate materials and alternate methods of construction.
- Only products which bear UL's Mark are considered Certified.

Joint Systems

XHBN - Joint Systems

XHBN7 - Joint Systems Certified for Canada

[See General Information for Joint Systems](#)[See General Information for Joint Systems Certified for Canada](#)

System No. HW-D-0585

January 5, 2022

ANSI/UL2079	CAN/ULC S115
Assembly Rating — 2 Hr	F Rating — 2 Hr
Nominal Joint Width - 1/2, 7/8, 1, 1-1/2, 1-1/16 or 2 in. (See Item 3)	FT Rating — 2 Hr
Class II or III Movement Capabilities — See Table 1	FH Rating — 2 Hr
L Rating At Ambient — 2.1 CFM/lin ft or Less Than 1 CFM/lin ft (See Item 3B)	FTH Rating — 2 Hr
L Rating At 400°F — 1.3 CFM/lin ft or Less Than 1 CFM/lin ft (See Item 3B)	Nominal Joint Width - 13, 22, 25, 38, 27 or 51 mm (See Item 3)
	Class II or III Movement Capabilities — See Table 1
	L Rating At Ambient — 3.25 L/s/m or Less Than 1.55 L/s/m (See Item 3B)
	L Rating At 204°C — 2.06 L/s/m or Less Than 1.55 L/s/m ft (See Item 3B)

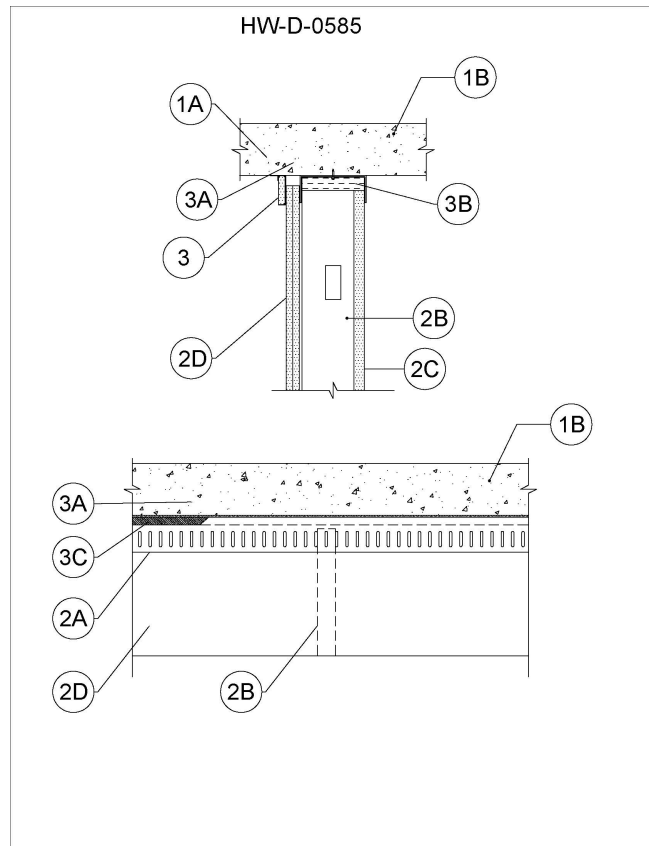

1. **Floor Assembly** — Concrete — Min 4-1/2 in. (114 mm) thick reinforced concrete.

2. **Shaft Wall Assembly** — The 2 hr fire rated gypsum board/stud wall assembly shall be constructed of the materials and in the manner described in the individual U400 or V400 Series Wall and Partition Design in the UL Fire Resistance Directory and shall include the following construction features:

A. **Steel Floor and Ceiling Runners** — Floor runner U-shaped, sized to accommodate steel studs (Item 2B), fabricated from min 24 ga galv steel. Runners attached to floor with steel fasteners located not greater than 2 in. from ends and not greater than 24 in OC. Ceiling runner fabricated from min 20 ga galv steel with flange height of legs of ceiling runners min 1 in. (25 mm) greater than max extended joint width. **When Item 3B, or 3B1 is used, the ceiling runners are provided with a fill, void or cavity material.**

A1. **Light Gauge Framing* — Slotted Ceiling Track** — (Not Shown) - As an alternate to the Item 2A, a ceiling track consisting of galv steel channel with slotted flanges may be used when Item 3B or 3B.1 is utilized. Slotted ceiling track sized to accommodate steel "C-T", "I" or "C-H" studs (Item 2C). Attached to steel deck with steel fasteners or welds spaced max 24 in. (610 mm) OC.

BRADY CONSTRUCTION INNOVATIONS INC, DBA SLIPTRACK SYSTEMS — SLP-TRK

CALIFORNIA EXPANDED METAL PRODUCTS CO — CST

B. **Studs** — "C-T", "I", or "C-H" shaped steel studs to be min 4 in. (102 mm) wide and formed of min 24 ga galv steel. Studs cut 2 to 2-1/4 (51 to 57mm) less in length than assembly height with bottom nesting in and secured to floor runner. Studs spaced max 24 in. (610 mm) OC.

C. **Gypsum Board*** — 1 in. (25 mm) thick by max 24 in. (610 mm) wide gypsum board liner panels. Panels cut 1-1/4 to 1-1/2 in. (32 to 38 mm) less in length than floor to ceiling height. Vertical edges inserted into "T" shaped section of "C-T" studs, into holding tabs of "I" studs or into "H"-shaped section of "C-H" studs.

D. **Gypsum Board*** — Gypsum board 1/2 or 5/8 in. (13 or 16 mm) thick, applied on finished side of wall as specified in the individual Wall and Partition Design. The boards cut a max 1-1/4 to 2 in. (32 to 51 mm) less in length than the floor to ceiling height. The screws attaching the gypsum board layer(s) to the "C-T", "I", or "C-H" studs shall be located between 4 and 5 in. (102 -127 mm) down from ceiling surface.

3. **Joint System** — Max separation between bottom of floor and top of gypsum board (at time of installation) is 7/8 in. (22 mm) or 1-1/16 in. (27 mm). When Item 3B is used the maximum separation between the bottom of the floor and the top of the gypsum board (at time of installation) is 7/8 in. (22 mm). When Item 3B.1 is used the maximum separation between the bottom of the floor and the top of the gypsum board (at time of installation) is 1/2 in. (13 mm). When items 3C, 3C1 or 3C2 are used, max separation between bottom of floor and top of gypsum board (at time of installation) is 1 in. (25 mm), 1-1/2 in. (38 mm), 2 in. (51 mm). The joint system is designed to accommodate compression and/or extension from its installed width as specified in Table 1 below.

A. **Forming Material*** — Min 2 in. thick min 4 pcf (64 kg/m³) mineral wool batt insulation cut to friction fit with min 33 percent compression in width and installed into ceiling runner between leg of track and gypsum liner board.

B. **Fill, Void or Cavity Material*** — Min 25 ga composite steel angle with one 5/8 in. (16 mm) leg and one 2-1/2 in (64 mm) leg with a strip of intumescent strip affixed along the inside 2-1/2 in (64 mm) leg. Steel angle is friction fit between the top web of the ceiling runner and the concrete deck.

CALIFORNIA EXPANDED METAL PRODUCTS CO — DDA (Deflection Drift Angle)

B1. **Fill, Void or Cavity Material*** — As an option to item 3B a min 25 ga composite steel angle with one 5/8 in. (16 mm) leg and one 1-1/4 in (32 mm) leg with a strip of intumescent strip affixed along the inside 1-1/4 in (32 mm) leg. Steel angle is friction fit between the top web of the ceiling runner and the concrete deck.

CALIFORNIA EXPANDED METAL PRODUCTS CO — DDA-1 (Deflection Drift Angle)

C. **Fill, Void or Cavity Material*** —For nom 1 in. (25 mm) or 2 in. (51 mm) joints, a nom 20 gauge steel angle encased on 3 sides over a nom 2-3/4 in. (70 mm) wide layer of 5/8 in. (16 mm) type X gypsum board. Angle to be secured to steel deck with steel masonry anchors spaced a max 24 in. (610 mm). Face of steel angle to be in contact with face of wall. Butt joints in FireRip to be offset min 16 (406 mm) on opposite sides of wall.

CALIFORNIA EXPANDED METAL PRODUCTS CO — FireRip-2

C1. **Fill, Void or Cavity Material*** - For nom 1-1/2 in. (38 mm) joints, a nom 20 gauge steel angle encased on 3 sides over a 3-3/4 in. (95 mm) wide layer of 5/8 in. (16 mm) Type X gypsum board. Angle to be secured to steel deck with steel masonry anchors spaced a max 24 in. (610 mm). Face of steel angle to be in contact with face of wall. Butt joints in FireRip to be offset min 16 in. (406 mm) on opposite sides of wall.

CALIFORNIA EXPANDED METAL PRODUCTS CO - FireRip-3

C2. **Fill, Void or Cavity Material*** - For nom 2 in. (51 mm) joints, a nom 20 gauge steel angle encased on 3 sides over a 4-3/4 in. (121 mm) wide layer of 5/8 in. (16mm) Type X gypsum board. Angle to be secured to steel deck with steel masonry anchors spaced a max 24 in. (610 mm). Face of steel angle to be in contact with face of wall. Butt joints in FireRip to be offset min 16 in. (406 mm) on opposite sides of wall.

CALIFORNIA EXPANDED METAL PRODUCTS CO - FireRip -4

Table 1

Model	Nominal Joint Size, in (mm)	Cycling Rating, %	
		Compression	Extension
FireRip-2	1 (25)	Compression	94
		Extension	100
	2 (51)	Compression	94
		Extension	6
FireRip-3	1-1/2 (38)	Compression	94
		Extension	42
FireRip-4	2 (51)	Compression	94
		Extension	6

D. **Fill, Void or Cavity Material*** (Not Shown) – Butt joints in the FireRip to be sealed with a min 1/4 (6 mm) bead of sealant. In addition, sealant shall be used to seal any voids and dimples within the fluted steel deck on both sides of wall to maintain L Ratings.

UNITED STATES GYPSUM CO – Type AS

*** Indicates such products shall bear the UL or cUL Certification Mark for jurisdictions employing the UL or cUL Certification (such as Canada), respectively.**

Last Updated on 2022-01-05

The appearance of a company's name or product in this database does not in itself assure that products so identified have been manufactured under UL's Follow-Up Service. Only those products bearing the UL Mark should be considered to be Certified and covered under UL's Follow-Up Service. Always look for the Mark on the product.

UL permits the reproduction of the material contained in the Online Certification Directory subject to the following conditions: 1. The Guide Information, Assemblies, Constructions, Designs, Systems, and/or Certifications (files) must be presented in their entirety and in a non-misleading manner, without any manipulation of the data (or drawings). 2. The statement "Reprinted from the Online Certifications Directory with permission from UL" must appear adjacent to the extracted material. In addition, the reprinted material must include a copyright notice in the following format: "© 2022 UL LLC"