

# XHBN.HW-D-0582 - Joint Systems

Design/System/Construction/Assembly Usage Disclaimer

- Authorities Having Jurisdiction should be consulted in all cases as to the particular requirements covering the installation and use of UL Certified products, equipment, system, devices, and materials.
- Authorities Having Jurisdiction should be consulted before construction.
- Fire resistance assemblies and products are developed by the design submitter and have been investigated by UL for compliance with applicable requirements. The published information cannot always address every construction nuance encountered in the field.
- When field issues arise, it is recommended the first contact for assistance be the technical service staff provided by the product manufacturer noted for the design. Users of fire resistance assemblies are advised to consult the general Guide Information for each product category and each group of assemblies. The Guide Information includes specifics concerning alternate materials and alternate methods of construction.
- Only products which bear UL's Mark are considered Certified.

## Joint Systems

XHBN - Joint Systems  
XHBN7 - Joint Systems Certified for Canada

[See General Information for Joint Systems](#)

[See General Information for Joint Systems Certified for Canada](#)

### System No. HW-D-0582

November 16, 2021

ANSI/UL2079	CAN/ULC S115
Assembly Ratings — 1 and 2 Hr (See Item 2)	F Ratings — 1 and 2 Hr (See Item 2)
Nominal Joint Width 3/4 in., 1 in., 1-1/2 in. and 2 in. (See Items 2 and 3)	FT Ratings — 1 and 2 Hr (See Item 2)
Class II or III Movement Capabilities — See Item 3	FH Ratings — 1 and 2 Hr (See Item 2)
L Rating at Ambient — Less than 1 CFM/Lin Ft	FTH Ratings — 1 and 2 Hr (See Item 2)
L Rating at 400°F — Less than 1 CFM/Lin Ft	Nominal Joint Width — 19 mm, 25 mm, 38 mm and 51 mm (See Items 2 and 3)
	Class II or III Movement Capabilities — See Item 3
	L Rating at Ambient — Less than 1.55 L/s/m
	L Rating at 204°C — Less than 1.55 L/s/m

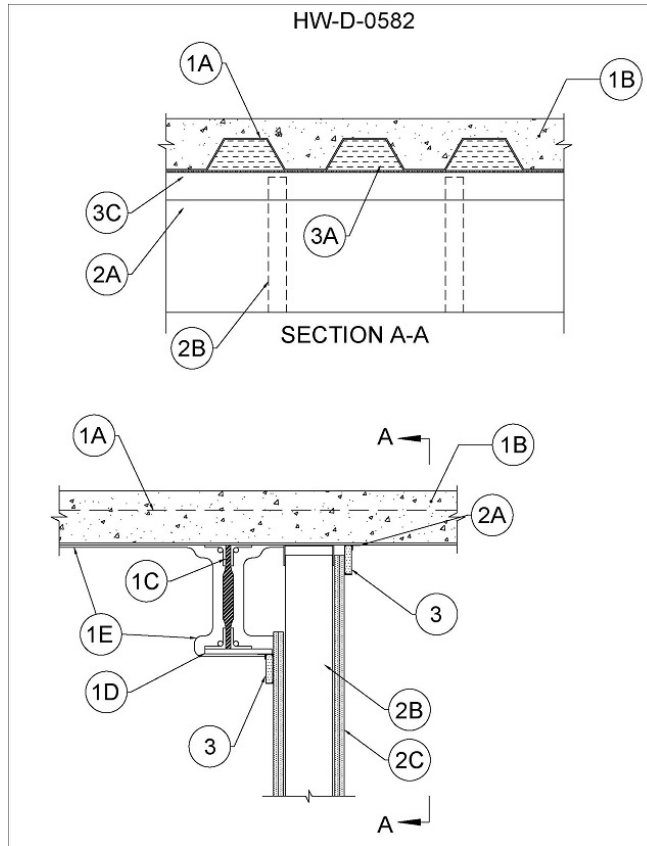

**1. Floor Assembly** — The fire-rated fluted steel deck/concrete floor assembly shall be constructed of the materials and in the manner described in the individual D700 or D900 Series Floor-Ceiling Design in the UL Fire Resistance Directory and shall include the following construction features:

**A. Steel Floor And Floor Units\*** — Max 3 in. (76 mm) deep galv steel fluted floor units.

**B. Concrete** — Min 2-1/2 in. (64 mm) thick reinforced concrete, as measured from the top plane of the floor units.

**C. Structural Steel Support** — Steel beam, as specified in the individual D700 or D900 Series Floor-Ceiling Design, used to support steel floor units. Structural steel support oriented parallel to and 1 to 7 in. (25 to 178 mm) from wall assembly.

**D. Steel Attachment Clips** — Z-shaped clips formed from 1 in. (25 mm) wide strips of min 20 ga galv steel. Clips to be sized to extend through the thickness of the spray-applied fire-resistive material on the bottom flange of the steel beam with 1-1/2 in. (38 mm) long upper and lower legs. Legs of clips fastened to bottom of beam (prior to application of spray-applied fire-resistive materials) with steel fasteners or welds. Clips spaced max 16 in. (406 mm) OC and extend to within 1/4 in. (6 mm) from the surface of the wall.

**E. Spray-Applied Fire Resistive Material\*** — After installation of the steel attachment clips, structural steel support and the steel floor units to be sprayed with the min thickness of material specified in the individual D700 Series Design. The flutes of the steel floor units are to be filled with material across the entire top flange of the steel beam. In addition, the flutes of the steel floor units immediately above the wall are to be filled with material to the full thickness of the wall (see Item 3B for alternate). The remainder of the steel floor units shall be sprayed as specified in the individual D700 design.

**ISOLATEK INTERNATIONAL** — Type 300

**GCP APPLIED TECHNOLOGIES INC** — Type MK-6/HY

**1A. Roof Assembly** — (Not Shown) — As an alternate to the floor assembly, a fire-rated fluted steel deck roof assembly may be used. The roof assembly shall be constructed of the materials and in the manner described in the individual P700 or P900 Series Roof-Ceiling Design in the UL Fire Resistance Directory. The roof assembly shall include the following construction features:

**A. Steel Roof Deck** — Max 3 in. (76 mm) deep galv steel fluted roof deck.

**B. Roof Insulation** — Min 2-1/4 in. (57 mm) thick poured insulating concrete, as measured from the top plane of the roof deck.

C. **Spray-Applied Fire Resistive Material\*** — After installation of the steel attachment clips, structural steel support and the steel deck are to be sprayed with the min thickness of material specified in the individual P700 or P900 Series Design. The flutes of the steel deck are to be filled with material across the entire top flange of the steel beam. In addition, the flutes of the steel deck immediately above the wall are to be filled with material to the full thickness of the wall (see Item 3B for alternate). The remainder of the steel floor units shall be sprayed when specified in the individual P700 design.  
**ISOLATEK INTERNATIONAL** — Type 300

**GCP APPLIED TECHNOLOGIES INC** — Type MK-6/HY

2. **Wall Assembly** — The 1 or 2 hr fire rated gypsum board/stud wall assembly shall be constructed of the materials and in the manner described in the individual U400 or V400 Series Wall and Partition Design in the UL Fire Resistance Directory and shall include the following construction features:

A. **Steel Floor and Ceiling Runners** — Floor and ceiling runners of wall assembly shall consist of min No. 20 gauge galv steel channels sized to accommodate steel studs (Item 2B). Ceiling runner to be provided with flanges that are min 1 in. (25 mm) longer than max extended joint width. For max ¼ in. nominal joint width, the non-slotted (3-1/4 in. or 83 mm deep) ceiling runners are provided with a fill, void or cavity material and are described in Item 3A. Ceiling runner installed perpendicular to direction of the fluted steel deck and secured through the spray-applied fire resistive material to steel deck valleys with steel masonry fasteners spaced max 24 in. (610 mm) OC or direct to steel fluted floor units where spray is not required.

A.1. **Light Gauge Framing\* — Slotted Ceiling Track** — (Not Shown) - As an alternate to the Item 2A, a ceiling track consisting of galv steel channel with slotted flanges may be used when Item 3A fill material is utilized. Slotted ceiling track sized to accommodate steel studs (Item 2B). Legs are to be min 1/4 in. (6 mm) longer than the maximum joint width. Attached to steel deck with steel fasteners or welds spaced max 24 in. (610 mm) OC.

**BRADY CONSTRUCTION INNOVATIONS INC, DBA SLIPTRACK SYSTEMS** — SLP-TRK

**CALIFORNIA EXPANDED METAL PRODUCTS CO** — CST, CST325

**MARINO/WARE, DIV OF WARE INDUSTRIES INC** — Type SLT

B. **Studs** — Steel studs to be min 3-5/8 in. (92 mm) wide and spaced max 24 in. (610 mm) on center. Studs cut 1-1/4 to 2 in. (32 to 51 mm) less in length than assembly height with bottom nesting in and secured to floor runner. Steel studs nested in non-slotted ceiling runner without attachment.

B1. **Framing Members - Steel Studs\*** — In lieu of Item 2B - Proprietary channel shaped studs, 3-5/8 in. (92 mm) wide spaced a max of 24 in. (610 mm) OC. Studs to be cut 1-1/4 to 2 in. (32 to 51 mm) less than the assembly height with bottom nesting in and secured to floor runner. For direct attachment of gypsum board only. Steel studs installed in non-slotted ceiling runner without attachment.

**CALIFORNIA EXPANDED METAL PRODUCTS CO** — ViperStud™

**MARINO/WARE, DIV OF WARE INDUSTRIES INC** — ViperStud™

C. **Gypsum Board\*** — Gypsum board sheets installed to a min total 5/8 in. (16 mm) or 1-1/4 in. (32 mm) thickness on each side of wall for 1 and 2 hr fire rated assemblies, respectively. Gypsum board to extend min 3 in. (76 mm) above the bottom of Z clips on side of wall adjacent to beam. Wall to be constructed as specified in the individual U400 or V400 Series Design in the UL Fire Resistance Directory except that a max 2 in. (51 mm) gap shall be maintained between the top of the gypsum board and the bottom of the spray-applied fire resistive material on steel floor or roof assembly on the full height wall side. The screws attaching the gypsum board to the studs along the top of the wall shall be located 1 to 3-1/2 in. (25 to 89 mm) below the bottom of the ceiling runner. No gypsum board attachment screws shall be driven into the ceiling runner.  
**The hourly rating of the joint system is equal to the lesser of the hourly ratings of the floor/roof-ceiling assembly and the wall assembly.**

3. **Joint System** — Max separation between bottom of spray-applied fire resistive material on steel floor or roof unit and top of wall (at time of installation of joint system) is 3/4 in. (19 mm), 1 in. (25 mm), 1-1/2 in. (38 mm) or 2 in. (51 mm). The joint system is designed to accommodate a max 80 percent compression and or 30 percent extension from its installed width when Item 3A is used. See Table 1 for movement for Joints outlined in Items 3C, C1 and C2.

A. **Fill, Void or Cavity Material\*** — Applies to 3/4 in. (19 mm) nominal joint width. Min. 25 ga composite steel angle with one 5/8 in. (16 mm) leg and one 2-1/2 in. (64 mm) leg with a 5/8 in. (16 mm) strip of intumescent strip affixed along the inside 2-1/2 in. (64 mm) leg. Steel angle is friction fit between the top web of the ceiling runner and the fluted steel deck on the full height gypsum board side only.

**CALIFORNIA EXPANDED METAL PRODUCTS CO** — DDA (Deflection Drift Angle)

B. **Packing Material** — Min 4 pcf (64 kg/m<sup>3</sup>) mineral wool batt insulation cut to the shape of the fluted deck, approx 33 percent larger than the height of the flutes and compressed into the fluted area of the steel floor or roof deck above the ceiling channel. The forming material shall be installed to extend over the full thickness of the wall and to outer edge of FireRip (when used). As an option, the spray-applied fire resistive material described in Item 1 can be used in place of the packing material.

**INDUSTRIAL INSULATION GROUP L L C** — MinWool-1200 Safing

**JOHNS MANVILLE** — Safing

**ROCK WOOL MANUFACTURING CO** — Delta Safing Board

**ROCKWOOL MALAYSIA SDN BHD** — SAFE

**ROCKWOOL** — SAFE

**THERMAFIBER INC** — SAF

B1. **Forming Material\*-Plugs** — (Not Shown) As an alternate to the forming material (Item 3B), mineral wool plugs preformed to the shape of the fluted floor units or roof deck, may be used within the flutes. Plugs shall be friction fitted to completely fill the flutes and extend to full thickness of wall or to outer edges of FireRip (when used).

**ROCK WOOL MANUFACTURING CO** — Delta Deck Plugs

C. **Fill, Void or Cavity Material\*** — For nom 1 in. (25 mm) or 2 in. (51 mm) joints, a nom 20 gauge steel angle encased on 3 sides over a nom 2-3/4 in. (70 mm) wide layer of 5/8 in. (16 mm) type X gypsum board. Angle to be secured to steel deck with steel masonry anchors spaced a max 24 in. (610 mm). Face of steel angle to be in contact with gypsum board on both sides of wall. Butt joints in FireRip to be offset min 12 in. (305 mm) on opposite sides of wall. At beam side of wall, the FireRip is to rest against the gypsum board on wall and be secured to steel attachment clips through the Item 3D gypsum board, with steel fasteners spaced 16 in. (406 mm) on center and of sufficient length to penetrate min ½ in. (13 mm) into the steel attachment clips.

**CALIFORNIA EXPANDED METAL PRODUCTS CO** — FireRip-2

C1. **Fill, Void or Cavity Material\*** - For nom 1-1/2 in. (38 mm) joints, a nom 20 gauge steel angle encased on 3 sides over a 3-3/4 in. (95 mm) wide layer of 5/8 in. (16 mm) Type X gypsum board. Angle to be secured to steel deck with steel masonry anchors spaced a max 24 in. (610 mm). Face of steel angle to be in contact with gypsum board on both sides of wall. Butt joints in FireRip to be offset min 12 in. (305 mm) on opposite sides of wall. At beam side of wall, the FireRip is to rest against the gypsum board on wall and be secured to steel attachment clips through the Item 3D gypsum board, with steel fasteners spaced 16 in. (406 mm) on center and of sufficient length to penetrate min ½ in. (13 mm) into the steel attachment clips.

**CALIFORNIA EXPANDED METAL PRODUCTS CO** - FireRip-3

C2. **Fill, Void or Cavity Material\*** - For nom 2 in. (51 mm) joints, a nom 20 gauge steel angle encased on 3 sides over a 4-3/4 in. (121 mm) wide layer of 5/8 in. (16mm) Type X gypsum board. Angle to be secured to steel deck with steel masonry anchors spaced a max 24 in. (610 mm). Face of steel angle to be in contact with gypsum board on both sides of wall. Butt joints in FireRip to be offset min 12 in. (305 mm) on opposite sides of wall. At beam side of wall, the FireRip is to rest against the gypsum board on wall and be secured to steel attachment clips through the Item 3D gypsum board, with steel fasteners spaced 16 in. (406 mm) on center and of sufficient length to penetrate min ½ in. (13 mm) into the steel attachment clips.

**CALIFORNIA EXPANDED METAL PRODUCTS CO** - FireRip -4

Table 1

Model	Nominal Joint Size, in (mm)	Cycling Movement, %	
FireRip-2	1 (25)	Compression	100
		Extension	100
	2 (51)	Compression	100
		Extension	0
FireRip-3	1-1/2 (38)	Compression	100
		Extension	100
FireRip-4	2 (51)	Compression	100
		Extension	50

D. **Gypsum Board\*** — Gypsum board sheets installed on underside of steel attachment clips (Item 1D) to a min total 5/8 in. (16 mm) or 1-1/4 in. (32 mm) thickness for 1 and 2 hr fire rated assemblies, respectively. Gypsum boards installed to completely cover the gap between steel beam and to within ¼ in. (6 mm) of wall and secured to each steel attachment clips with a minimum of two steel drywall screws approximately 1 to 2 in. (25 to 51 mm) from each end of the clip.

D1. **Gypsum Board\*** — **Not applicable when Items 3C, C1 and C2 are used.** Not shown as an alternate to D. Gypsum board Nom 3/8 in. (10 mm) diamond mesh expanded steel rib lath having a nom weight of 3.4 lb/yd<sup>2</sup> (1.8 kg/m<sup>2</sup>) shall be installed over and attached to the steel attachment clip bars or channels (Item 1D) to completely cover the exposed area from the flange tip of the steel beam to the end of the bar/channel framing extending beyond the wall surface. The lath shall be secured with steel fasteners or tie wire and shall be fully covered with spray applied fire resistive material (Item 1E).

E. **Fill, Void or Cavity Material\*** — (Not Shown) When item 3A is utilized, a min 1/16 in. (1.6 mm) dry thickness (min 1/8 in. or 3.2 mm wet thickness) of fill material sprayed or brushed on one side of the joint system, completely covering item 3B mineral wool forming material of the joint system and overlapping a min of 1/2 in. (13 mm) onto the steel deck and item 3A DDA on one side of the wall.

**HILTI CONSTRUCTION CHEMICALS, DIV OF HILTI INC** — CP672 Firestop Spray or CFS-SP WB. Firestop Joint Spray

**SPECIFIED TECHNOLOGIES INC** — SpecSeal AS200 Elastomeric Spray

**UNITED STATES GYPSUM CO** — Type AS

F. **Fill, Void or Cavity Material\*** (Not Shown) — Butt joints in the FireRip to be sealed with a min 1/4 in. (6 mm) bead of sealant. In addition, sealant shall be used to seal any voids and dimples within the fluted steel deck and at the beam shelf on both sides of wall to maintain L Ratings.

**UNITED STATES GYPSUM CO** - Type AS

\* Indicates such products shall bear the UL or cUL Certification Mark for jurisdictions employing the UL or cUL Certification (such as Canada), respectively.

The appearance of a company's name or product in this database does not in itself assure that products so identified have been manufactured under UL's Follow-Up Service. Only those products bearing the UL Mark should be considered to be Certified and covered under UL's Follow-Up Service. Always look for the Mark on the product.

UL permits the reproduction of the material contained in the Online Certification Directory subject to the following conditions: 1. The Guide Information, Assemblies, Constructions, Designs, Systems, and/or Certifications (files) must be presented in their entirety and in a non-misleading manner, without any manipulation of the data (or drawings). 2. The statement "Reprinted from the Online Certifications Directory with permission from UL" must appear adjacent to the extracted material. In addition, the reprinted material must include a copyright notice in the following format: "© 2022 UL LLC"