

XHBN.HW-D-0541 - Joint Systems

Design/System/Construction/Assembly Usage Disclaimer

- Authorities Having Jurisdiction should be consulted in all cases as to the particular requirements covering the installation and use of UL Certified products, equipment, system, devices, and materials.
- Authorities Having Jurisdiction should be consulted before construction.
- Fire resistance assemblies and products are developed by the design submitter and have been investigated by UL for compliance with applicable requirements. The published information cannot always address every construction nuance encountered in the field.
- When field issues arise, it is recommended the first contact for assistance be the technical service staff provided by the product manufacturer noted for the design. Users of fire resistance assemblies are advised to consult the general Guide Information for each product category and each group of assemblies. The Guide Information includes specifics concerning alternate materials and alternate methods of construction.
- Only products which bear UL's Mark are considered Certified.

XHBN - Joint Systems

XHBN7 - Joint Systems Certified for Canada

[See General Information for Joint Systems](#)

[See General Information for Joint Systems Certified for Canada](#)

System No. HW-D-0541

September 01, 2016

ANSI/UL2079

CAN/ULC S115

Assembly Rating — 2 Hr	F Rating — 2 Hr
Nominal Joint Width - 3/4 In.	FT Rating — 2 Hr
Class II Movement Capabilities — 16% Compression and Extension	FH Rating — 2 Hr
	FTH Rating — 2 Hr
	Nominal Joint Width - 3/4 In.
	Class II Movement Capabilities — 16% Compression and Extension

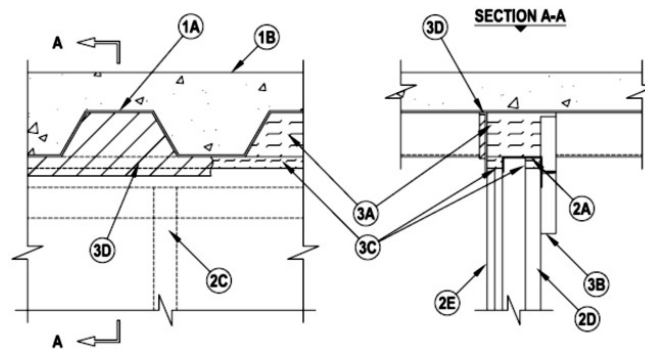

1. Floor Assembly — The fire-rated fluted steel deck/concrete floor assembly shall be constructed of the materials and in the manner described in the individual Floor-Ceiling Design in the UL Fire Resistance Directory. The floor assembly shall include the following construction features:

A. Steel Floor and Form Units* — Max 3 in. (76 mm) deep galv fluted floor units.

B. Concrete — Min 2-1/2 in. (64 mm) thick reinforced (100-150 pcf 1600-2400 kg/m³) concrete, as measured from the top plane of the floor units.

C. Spray-Applied Fire Resistive Materials* — (Optional, Not Shown)—Prior to or after the installation of the steel ceiling runners, and prior to the installation of the Forming Material and Fill, Void or Cavity Material (Items 2A, 3A, 3B, respectively) the steel floor units may be sprayed with a min 5/16 in. (8 mm) to max 1-3/4 in. (45 mm) thickness of fire resistive material.

ISOLATEK INTERNATIONAL — Type 300

GCP APPLIED TECHNOLOGIES INC — Type MK-6-HY

2. Shaft Wall Assembly — The 2 hr fire-rated gypsum board /steel stud shaft wall assembly shall be constructed of the materials and in the manner described in the individual U400, V400 or W400 Series Wall and Partition Design in the UL Fire Resistance Directory and shall include the following construction features:

A. Floor and Ceiling Runners — J-shaped runner, min 2-1/2 in. (64 mm) wide with unequal legs of 1 in. and 2 in. (25 and 51 mm), fabricated from 24 MSG galv steel. Runners positioned with short leg toward finished side of wall. Runners attached to floor with steel fasteners steel masonry anchors or welds located not greater than 2 in. (51 mm) from ends and not greater than 24 in. (610 mm) OC. The use of welds to secure the ceiling runner may only be used prior to the installation of the optional spray-applied material.

A1. Light Gauge Framing*—Slotted Ceiling Runner — As an alternate to the ceiling runner in Item 2A, slotted ceiling runner to consist of galv steel channel with slotted flanges sized to accommodate steel studs (Item 2C). Slotted ceiling runner installed perpendicular to direction of fluted steel deck and secured to valleys with steel masonry anchors, steel fasteners or welds spaced max 24 in. (610 mm) OC before or after optional spray-applied fire resistive material is used. The use of welds to secure the ceiling runner may only be used prior to the installation of the optional spray-applied material.

BRADY CONSTRUCTION INNOVATIONS INC, DBA SLIPTRACK SYSTEMS — SLP-TRK

CALIFORNIA EXPANDED METAL PRODUCTS CO — CST

CLARKDIETRICH BUILDING SYSTEMS — Type SLT, SLT-H

MARINO/WARE, DIV OF WARE INDUSTRIES INC — Type SLT

METAL-LITE INC — The System

RAM SALES L L C — RAM Slotted Track

SCAFCO STEEL STUD MANUFACTURING CO — Slotted Track

TELLING INDUSTRIES L L C — True-Action Deflection Track

B. Steel Attachment Clips — (Optional - Not Shown) - When spray applied fireproofing is used ceiling runner may be secured to deck with Z-shaped clips formed from min 1 in. (25 mm) long strips of min 20 ga galv steel. Length of clips should not exceed the width (thickness) of the wall. Clips to be sized to extend through the thickness of the spray-applied fire-resistive material on the bottom of the steel deck with 1-1/2 or 2 in. (38 or 51 mm) long upper and lower legs. Legs of clips fastened to valleys of steel deck (prior to application of spray-applied fire-resistive materials) and top of ceiling runner with masonry anchors, steel fasteners or welds. Clips spaced max 24 in. (610 mm) OC.

C. Steel Studs — C-H-shaped studs, min 2-1/2 in. wide by 1-1/2 in. deep, (64 mm wide by 38 mm deep) fabricated from 25 MSG galv steel, cut to lengths 3/8 to 1/2 in. (10 to 13 mm) less than floor to ceiling height and spaced 24 in. (610 mm) OC.

D. Gypsum Board* — 1 in. (25 mm) thick gypsum board liner panels. Panels cut 3/4 in. (19 mm) less in length than floor to ceiling height. Vertical edges inserted in H-shaped section of C-H studs. At the ends of the assembly, the free edge of the end panels are attached to the long leg of vertical J-runners (Item 2A) with 1-5/8 in. (41 mm) long Type S steel screws spaced max 12 in. (305 mm) OC.

E. Gypsum Board* — Min 1/2 in. (13 mm) thick, "Type C" gypsum board applied vertically in two layers. Panels cut 3/4 in. (19 mm) less in length than floor to ceiling height. The screws attaching the gypsum board layers to the C-H studs shall be located 1 in. (25 mm) below the bottom of the J-runner or slotted ceiling track. No gypsum board attachment screws are to penetrate the ceiling J-runner and slotted ceiling track.

3. Joint System — Max separation between bottom of fluted deck surface and top of gypsum board (at the time of installation of the joint system) is 3/4 in. The joint system is designed to accommodate a max 16 percent compression or extension from its installed width. The joint system consists of the following:

A. Packing Material — Min 4 pcf (64 kg/m³) density mineral wool batt insulation cut to the shape of the fluted deck, 50 percent larger than the area of the flutes and compressed into the flutes of the steel floor units above the ceiling runner as a permanent form. The mineral wool batt insulation is to project beyond the ceiling runner flush with the finished wall surface.

ROCK WOOL MANUFACTURING CO — Delta-Board

A1. **Forming Material*—Plugs** — (Optional, Not Shown) As an alternate to item 3A. Preformed mineral wool plugs, formed to the shape of the fluted floor units, friction fit to completely fill the flutes above the ceiling channel. The plugs shall project beyond the finished side of the ceiling runner, flush with wall surface.

HILTI CONSTRUCTION CHEMICALS, DIV OF HILTI INC — CP777 Speed Plugs

B. **Wall Cladding** — Min 1 in. (25 mm) thick gypsum board (Item 2D) cut to the contour of the steel floor units. Cladding can be attached from either side of the runner leg on the unfinished surface of the wall. The wall cladding is attached at the mid-height location of the long leg of the J-shaped runner with 1-5/8 in. (41 mm) Type 5 drywall screws 6 in. (152 mm) in from each end and max 12 in. (305 mm) O.C. in between. The screws are to be positioned such that they avoid the locations of the steel studs. The top of the wall cladding shall be recessed min 1/8 in. to max 1/4 in. (3 to 6 mm) from the steel floor units and overlap the gypsum board min 5 in. (127 mm) as measured from the top of the ceiling runner.

C. **Fill, Void or Cavity Material** — Min 4 pcf (64 kg/m³) density mineral wool batt insulation cut approximately 50 larger than the area between the gypsum board and the bottom of the steel floor unit compressed and installed on finished side of the wall between the top of the gypsum board and the bottom of the steel floor units, flush with the surface of the wall and compressed and installed within J-shaped runner above top of liner panel flush with the inside surface of the panel.

C1. **Forming Material* - Strips** — (Optional) - As an alternate to item 3C when 5/8 in. (16 mm) or thicker gypsum board is used (Item 3D). The strips are compressed 50 percent and firmly packed, cut edge first, on both sides of the wall between the top of the gypsum board and the bottom of the steel floor units, flush with the finished surface of the wall and packed within J-shaped runner above top of liner panel flush with the inside surface of the panel.

HILTI CONSTRUCTION CHEMICALS, DIV OF HILTI INC — CP 767 Speed Strips

D. **Fill, Void or Cavity Material*** — Min 1/16 in. (1.6 mm) dry thickness (1/8 in. or 3.2 mm wet thickness) of fill material sprayed or troweled on finished side of the wall to completely cover mineral wool forming material and to overlap a min of 1/2 in. (13 mm) onto gypsum board and steel deck on finished side of wall. When Spray-Applied Fire Resistive Material*(Item 1C) is applied to the Steel Floor and Form Units* (Item 1A), the fill material is to overlap the gypsum board a min of 1/2 in. (13 mm) and the Spray-Applied Fire Resistive Material a min of 2 in. (51 mm) on finished side of wall.

HILTI CONSTRUCTION CHEMICALS, DIV OF HILTI INC — CP 672 Firestop Spray or CFS-SP WB Firestop Joint Spray

*** Indicates such products shall bear the UL or cUL Certification Mark for jurisdictions employing the UL or cUL Certification (such as Canada), respectively.**

[Last Updated](#) on 2016-09-01

The appearance of a company's name or product in this database does not in itself assure that products so identified have been manufactured under UL's Follow-Up Service. Only those products bearing the UL Mark should be considered to be Certified and covered under UL's Follow-Up Service. Always look for the Mark on the product.

UL permits the reproduction of the material contained in the Online Certification Directory subject to the following conditions: 1. The Guide Information, Assemblies, Constructions, Designs, Systems, and/or Certifications (files) must be presented in their entirety and in a non-misleading manner, without any manipulation of the data (or drawings). 2. The statement "Reprinted from the Online Certifications Directory with permission from UL" must appear adjacent to the extracted material. In addition, the reprinted material must include a copyright notice in the following format: "© 2022 UL LLC"