

## XHBN.HW-D-0457 - Joint Systems

Design/System/Construction/Assembly Usage Disclaimer

- Authorities Having Jurisdiction should be consulted in all cases as to the particular requirements covering the installation and use of UL Certified products, equipment, system, devices, and materials.
- Authorities Having Jurisdiction should be consulted before construction.
- Fire resistance assemblies and products are developed by the design submitter and have been investigated by UL for compliance with applicable requirements. The published information cannot always address every construction nuance encountered in the field.
- When field issues arise, it is recommended the first contact for assistance be the technical service staff provided by the product manufacturer noted for the design. Users of fire resistance assemblies are advised to consult the general Guide Information for each product category and each group of assemblies. The Guide Information includes specifics concerning alternate materials and alternate methods of construction.
- Only products which bear UL's Mark are considered Certified.

## XHBN - Joint Systems

## System No. HW-D-0457

October 19, 2015

## Assembly Ratings — 1 and 2 Hr (See Item 2)

## Nominal Joint Width — 1 in.

## L Rating At Ambient — Less Than 1 CFM/Lin Ft

## L Rating At 400°F — Less Than 1 CFM/Lin Ft

## Class II Movement Capabilities — 19% Compression or Extension

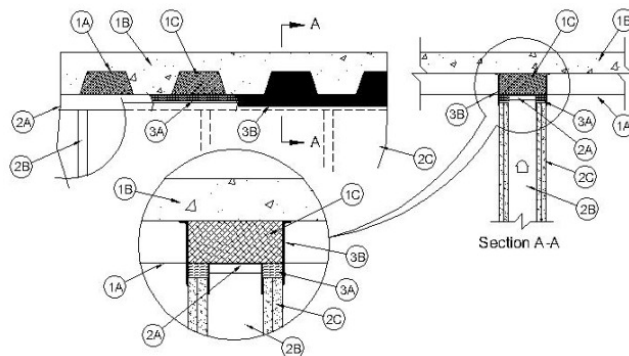

**1. Floor Assembly** — The fire-rated fluted steel deck/concrete floor assembly shall be constructed of the materials and in the manner described in the individual D700-, D800- or D900-Series **Floor-Ceiling** designs in the UL Fire Resistance Directory and shall include the following construction features:

**A. Steel Floor and Floor Units\*** — Max 3 in. (76 mm) deep galv steel fluted floor units.

**B. Concrete** — Min 2-1/2 in. (64 mm) thick reinforced concrete, as measured from the top plane of the floor units.

**C. Spray-Applied Fire Resistive Material\*** — After installation of the ceiling runner (Item 2A), the structural steel supports and steel floor units (if required) are to be sprayed with the thickness and density of material specified in the individual D700-, D800- or D900-Series Floor-Ceiling Design. The steel floor unit flute area immediately above the ceiling runner is to be completely filled with spray-applied fire resistive material. Material in flutes is also to extend 5/8 or 1-1/4 in. (16 or 32 mm) beyond each side of the ceiling runner so as to be approx flush with each surface of the finished wall. The required thickness of spray-applied fire resistive material on the valleys of the steel deck shall also be applied to the material filling the flutes so as to maintain a uniform gap width between the material and the gypsum board across the top of the wall.

**ISOLATEK INTERNATIONAL** — Type 300 or Type II

**1A. Roof Assembly** — (Not Shown) - As an alternate to the floor assembly, a fire-rated fluted steel deck roof assembly may be used. The roof shall be constructed of the materials and in the manner described in the individual P700-, P800- or P900-Series R roof-Ceiling designs in the UL Fire Resistance Directory. The hourly rating of the roof assembly shall be equal to or greater than the hourly rating of the wall assembly. The roof assembly shall include the following construction features:

**A. Steel Roof Deck** — Max 3 in. (76 mm) deep galv steel fluted roof deck.

**B. Roof Insulation** — For P900-Series Roof-Ceiling designs, roof insulation to consist of min 2-1/4 in. (57 mm) thick poured insulating concrete, as measured from the top plane of the roof deck. For P800-Series Roof-Ceiling designs, roof insulation to consist of mineral and fiber boards or foamed plastic boards which are applied over gypsum sheathing attached to the steel roof deck.

**C. Spray-Applied Fire Resistive Material\*** — After installation of the slotted ceiling runner angles (Item 2A), the steel roof deck and structural steel supports are to be sprayed with the thickness and density of material specified in the individual P700-, P800- or P900-Series Roof-Ceiling Design. The steel roof deck flute area immediately above and between the slotted ceiling runner angles is to be completely filled with spray applied fire resistive material. Material in flutes is also to extend 5/8 or 1-1/4 in. (16 or 32 mm) beyond each side of the ceiling runner so as to be approx flush with each surface of the finished wall. The required thickness of spray-applied fire resistive material on the valleys of the steel deck shall also be applied to the material filling the flutes so as to maintain a uniform gap width between the material and the gypsum board across the top of the wall.

**ISOLATEK INTERNATIONAL** — Type 300 or Type II

**2. Wall Assembly** — The 1 hr or 2 hr fire rated gypsum board/steel stud wall assembly shall be constructed of the materials and in the manner described in the individual U400- or V400-Series Wall and Partition Design in the UL Fire Resistance Directory but shall include the following construction features:

**A. Steel Floor and Ceiling Runners** — Floor and ceiling runners of wall assembly shall consist of galv steel channels sized to accommodate steel studs (Item 2B). Flange height of ceiling runner shall be min 3/4 in. (19 mm) greater than nom joint width. Ceiling runner installed perpendicular to direction of fluted steel deck and secured to valleys with steel masonry anchors or welds spaced max 24 in. (610 mm) OC.

**A1. Light Gauge Framing\* - Slotted Ceiling Runner** — As an alternate to the ceiling runner in Item 2A, ceiling runner to consist of galv steel channel with slotted flanges sized to accommodate steel studs (Item 2B). Ceiling runner secured to bottom of concrete floor with steel fasteners spaced max 24 in. (610 mm) OC. When slotted ceiling runner is used, deflection channel (Item 3A) shall not be used.

**CALIFORNIA EXPANDED METAL PRODUCTS CO** — CST

**MARINO/WARE, DIV OF WARE INDUSTRIES INC** — Type SLT

**B. Studs** — Studs to be min 3-1/2 in. (89 mm) wide and formed from min 20 ga galv steel. Studs cut 1/2 to 1 in. (13 to 25 mm) less in length than assembly height with bottom nesting in and resting on floor runner and with top nesting in ceiling runner (Item 2A). Stud spacing not to exceed 24 in. (610 mm) OC.

**C. Gypsum Board\*** — Gypsum board sheets installed to a min total thickness of 5/8 or 1-1/4 in. (16 or 32 mm) on each side of wall for 1 hr or 2 hr fire rated assemblies, respectively. Wall to be constructed as specified in the individual U400- or V400-Series Wall and Partition Design except that a max 1 in. (25 mm) gap shall be maintained between the top of the gypsum board and the spray-applied fire resistive material. The uppermost screws securing the gypsum board to the studs shall be located 1/2 to 1 in. (13 to 25 mm) below the bottom edge of the ceiling runner.

**The hourly fire rating of the joint system is equal to the hourly fire rating of the wall.**

**3. Joint System** — Max separation between bottom of floor and top of gypsum board (at time of installation of joint system) is 1 in. (25 mm). The joint system is designed to accommodate a max 19 percent compression or extension from its installed width. The joint system shall consist of forming and fill materials, as follows:

**A. Forming Material\*** — Sections of min 4 pcf (64 kg/m<sup>3</sup>) density mineral wool batt compressed 50 percent in thickness and installed cut edge first to completely fill the gap between the top of the gypsum board and the bottom of the steel deck and/or spray-applied fire resistive material. The forming material shall be installed flush with both surfaces of wall.

**INDUSTRIAL INSULATION GROUP L L C** — MinWool-1200 Safing

**JOHNS MANVILLE** — Safing

**ROCKWOOL MALAYSIA SDN BHD** — Safe

**ROCKWOOL** — Safe

**ROCK WOOL MANUFACTURING CO** — Delta Board

**8. Fill, Void or Cavity Material\* — Sealant** — Min 1/16 in. (1.6 mm) dry thickness (1/8 in. or 3.2 mm wet thickness) of sealant spray-applied to cover mineral wool batt forming material and spray-applied fire resistive material in flutes of steel deck on each side of the wall. Sealant to overlap a min of 1/2 in. (13 mm) onto gypsum board and onto steel deck (or spray-applied fire resistive material on steel deck) on both sides of wall.  
**SPECIFIED TECHNOLOGIES INC** — SpecSeal AS200 Elastomeric Spray

**\* Indicates such products shall bear the UL or cUL Certification Mark for jurisdictions employing the UL or cUL Certification (such as Canada), respectively.**

[Last Updated](#) on 2015-10-19

---

The appearance of a company's name or product in this database does not in itself assure that products so identified have been manufactured under UL's Follow-Up Service. Only those products bearing the UL Mark should be considered to be Certified and covered under UL's Follow-Up Service. Always look for the Mark on the product.

UL permits the reproduction of the material contained in the Online Certification Directory subject to the following conditions: 1. The Guide Information, Assemblies, Constructions, Designs, Systems, and/or Certifications (files) must be presented in their entirety and in a non-misleading manner, without any manipulation of the data (or drawings). 2. The statement "Reprinted from the Online Certifications Directory with permission from UL" must appear adjacent to the extracted material. In addition, the reprinted material must include a copyright notice in the following format: "© 2022 UL LLC"