

XHBN.HW-D-0421 - Joint Systems

Design/System/Construction/Assembly Usage Disclaimer

- Authorities Having Jurisdiction should be consulted in all cases as to the particular requirements covering the installation and use of UL Certified products, equipment, system, devices, and materials.
- Authorities Having Jurisdiction should be consulted before construction.
- Fire resistance assemblies and products are developed by the design submitter and have been investigated by UL for compliance with applicable requirements. The published information cannot always address every construction nuance encountered in the field.
- When field issues arise, it is recommended the first contact for assistance be the technical service staff provided by the product manufacturer noted for the design. Users of fire resistance assemblies are advised to consult the general Guide Information for each product category and each group of assemblies. The Guide Information includes specifics concerning alternate materials and alternate methods of construction.
- Only products which bear UL's Mark are considered Certified.

Joint Systems

XHBN - Joint Systems

[See General Information for Joint Systems](#)

System No. HW-D-0421

November 16, 2021

| ANSI/UL2079 | CAN/ULC 5115 |
|---|---|
| Assembly Ratings — 1 and 2 Hr (See Item 2) | F Ratings — 1 and 2 Hr (See Item 2) |
| Nominal Joint Width — 1 and 2 In. | FT Ratings — 1 and 2 Hr (See Item 2) |
| Class II or III Movement Capabilities — See Table 1 | FH Ratings — 1 and 2 Hr (See Item 2) |
| L Rating at Ambient — Less than 1 CFM/Lin Ft | FTH Ratings — 1 and 2 Hr (See Item 2) |
| L Rating at 400°F — Less than 1 CFM/Lin Ft | Nominal Joint Width -25 and 51 mm |
| | Class II or III Movement Capabilities — See Table 1 |
| | L Rating at Ambient — Less than 1.55 L/s/m |
| | L Rating at 204°C — Less than 1.55 L/s/m |

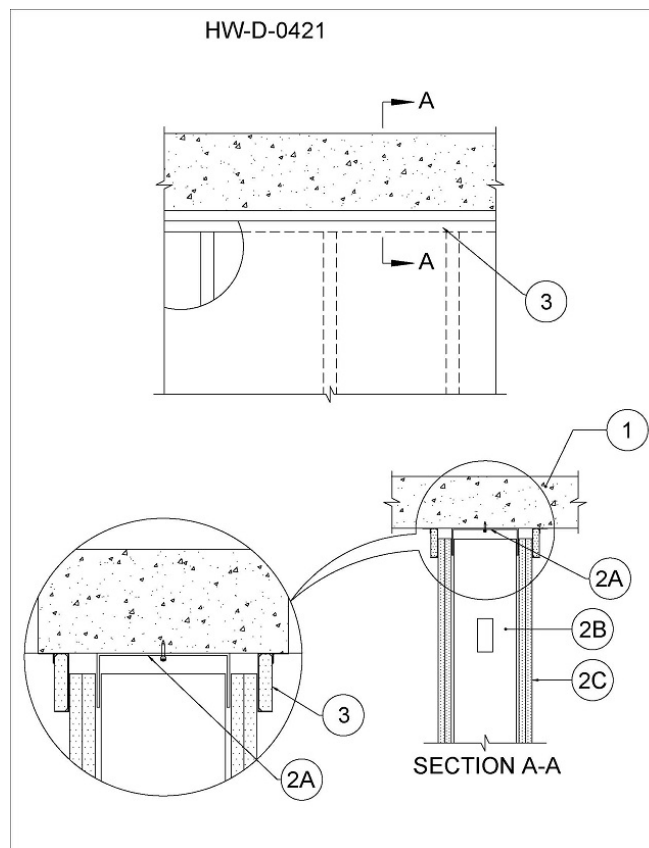

1. Floor Assembly — Min 4-1/2 in. (114 mm) thick steel reinforced lightweight or normal weight (100-150 pcf or 1600-2400 kg/m³) structural concrete. Floor may also be constructed of any min 6 in. thick UL Classified hollow-core **Precast Concrete Units**®. See **Precast Concrete Units** (CFTV) category in the Fire Resistance Directory for names of manufacturers.

The hourly fire rating of the floor assembly shall be equal or greater than the hourly fire rating of the wall assembly.

2. Wall Assembly — The 1 or 2 hr fire rated gypsum board/stud wall assembly shall be constructed of the materials and in the manner described in the individual U400 or V400 Series Wall and Partition Design in the UL Fire Resistance Directory and shall include the following construction features:

A. Steel Floor and Ceiling Runners — Floor and ceiling runners of wall assembly shall consist of min No. 20 gauge galv steel channels sized to accommodate steel studs (Item 2B). Ceiling runner to be provided with flanges that are min 1 in. (25 mm) longer than max extended joint width. When U-shaped deflection channel is used, ceiling runner is installed within the U-shaped deflection channel (Item 2A1) with max 2 in. (51 mm) gap maintained between the top of ceiling runner and top of deflection channel. When deflection channel is not used, ceiling runner secured to floor assembly with steel fasteners spaced a max 24 in. (610 mm) OC.

A1. Deflection Channel — (Optional) - U-shaped channel formed from min 25 gauge galv steel sized to accommodate ceiling runner and provided with flanges that are min 1 in. (25 mm) longer than max extended joint width. Deflection channel secured to floor assembly with steel fasteners spaced max 24 in. (610 mm) OC. The ceiling runner (Item 2A) is installed within the deflection channel to maintain a 2 in. (51 mm) gap between the top of the ceiling runner and the top of the deflection channel. The ceiling runner is not fastened to the deflection channel.

A2. Light Gauge Framing®-Slotted Ceiling Runner — As an alternate to the ceiling runner in Item 2A, slotted ceiling runner to consist of galv steel channel with slotted flanges, sized to accommodate steel studs (Item 2B). Slotted ceiling runner secured to floor assembly with steel fasteners spaced max 24 in. (610 mm) OC. When slotted ceiling runner is used, deflection channel shall not be used.

BRADY CONSTRUCTION INNOVATIONS INC, DBA SLIPTRACK SYSTEMS — SLP-TRK

CALIFORNIA EXPANDED METAL PRODUCTS CO — CST

METAL-LITE INC — The System

SCAFCO STEEL STUD MANUFACTURING CO — Slotted Track

TELLING INDUSTRIES L L C — True-Action Deflection Track

A3. **Light Gauge Framing* — Clipped Ceiling Runner** — As an alternate to the ceiling runner in Item 2A, clipped runner to consist of galv steel channel with clips preformed in track flanges which positively engage the inside flange of the steel studs (Item 2B). Track sized to accommodate steel studs (Item 2B). Track flanges to be min 1 in. (25 mm) longer than max extended joint width. Clipped ceiling runner secured to floor assembly with steel fasteners spaced max 24 in. (610 mm) OC. When clipped ceiling runner is used, deflection channel shall not be used.
TOTAL STEEL SOLUTIONS L L C — Snap Trak

A4. **Light Gauge Framing* — Vertical Deflection Ceiling Runner** — As an alternate to the ceiling runner in Items 2A, vertical deflection ceiling runner to consist of galv steel channel with slotted vertical deflection clips mechanically fastened within runner. Slotted clips, provided with step bushings, for permanent fastening of steel studs. Track sized to accommodate steel studs (Item 2B). Vertical deflection ceiling runner secured to floor assembly with steel fasteners spaced max 24 in. OC. When slotted ceiling runner is used, deflection channel shall not be used.
THE STEEL NETWORK INC — VentiTrack VTD362, VTD400, VTD600 and VTD800

B. **Studs** — Steel studs to be min 3-5/8 in. (92 mm) wide. Studs cut 1/2 in. to 2 in. (13 to 51 mm) less in length than assembly height with bottom nesting in and secured to floor runner. When slotted ceiling runner (Item 2A2) is used, steel studs secured to slotted ceiling runner with No. 8 by 1/2 (13 mm) long wafer head steel screws at mid-height of slot on each side of wall. Studs to nest in ceiling runner without attachment.

C. **Gypsum Board*** — Gypsum board sheets installed to a min total 5/8 in. (16 mm) or 1-1/4 in. (32 mm) thickness on each side of wall for 1 and 2 hr fire rated assemblies, respectively. Wall to be constructed as specified in the individual U400 or V400 Series Design in the UL Fire Resistance Directory except that a max 2 in. (51 mm) gap shall be maintained between the top of the gypsum board and the bottom of the floor assembly. The screws attaching the gypsum board to the studs along the top of the wall shall be located 1 to 3-1/2 in. (25 to 89 mm) below the bottom of the ceiling runner. No gypsum board attachment screws shall be driven into the ceiling runner.

The hourly fire rating of the joint system is equal to the hourly fire rating of the wall.

3. **Joint System — Max separation between bottom of floor and top of wall (at time of installation of joint system) is 1 in. (25 mm) or 2 in. (51 mm)The joint system is designed to accommodate compression and/or extension from its installed width as noted in Table 1 below.**

A. **Fill, Void or Cavity Material*** — For nom 1 in. (25 mm) or 2 in. (51 mm) joints, a nom 20 gauge steel angle encased on 3 sides over a nom 2-3/4 in. (70 mm) wide layer of 5/8 in. (16 mm) type X gypsum board. Angle to be secured to steel deck with steel masonry anchors spaced a max 24 in. (610 mm). Face of steel angle to be in contact with gypsum board on both sides of wall. Butt joints in FireRip to be offset min 12 in. (305 mm) on opposite sides of wall.
CALIFORNIA EXPANDED METAL PRODUCTS CO — FireRip-2

A1. **Fill, Void or Cavity Material*** — For nom 2 in. (51 mm) joints, a nom 20 gauge steel angle encased on 3 sides over a 4-3/4 in. (121 mm) wide layer of 5/8 in. (16mm) Type X gypsum board. Angle to be secured to steel deck with steel masonry anchors spaced a max 24 in. (610 mm). Face of steel angle to be in contact with gypsum board on both sides of wall. Butt joints in FireRip to be offset min 12 in. (305 mm) on opposite sides of wall.
CALIFORNIA EXPANDED METAL PRODUCTS CO — FireRip -4

Table 1

| Model | Nominal Joint Size, in (mm) | Cycling Movement, % | |
|-----------|-----------------------------|---------------------|-----------|
| | | Compression | Extension |
| FireRip-2 | 1 (25) | Compression | 100 |
| | | Extension | 100 |
| | 2 (51) | Compression | 100 |
| | | Extension | 0 |
| FireRip-4 | 2 (51) | Compression | 100 |
| | | Extension | 50 |

B. **Fill, Void or Cavity Material*** - Butt Joints in the FireRip to be sealed with a min 1/4 in. (6 mm) bead of sealant. In addition, sealant shall be used to seal any voids and dimples within the fluted deck at the interface with FireRip on both sides of wall to maintain L ratings.

UNITED STATES GYPSUM CO - Type AS

*** Indicates such products shall bear the UL or cUL Certification Mark for jurisdictions employing the UL or cUL Certification (such as Canada), respectively.**

Last Updated on 2021-11-16

The appearance of a company's name or product in this database does not in itself assure that products so identified have been manufactured under UL's Follow-Up Service. Only those products bearing the UL Mark should be considered to be Certified and covered under UL's Follow-Up Service. Always look for the Mark on the product.

UL permits the reproduction of the material contained in the Online Certification Directory subject to the following conditions: 1. The Guide Information, Assemblies, Constructions, Designs, Systems, and/or Certifications (files) must be presented in their entirety and in a non-misleading manner, without any manipulation of the data (or drawings). 2. The statement "Reprinted from the Online Certifications Directory with permission from UL" must appear adjacent to the extracted material. In addition, the reprinted material must include a copyright notice in the following format: "© 2022 UL LLC"