

## XHBN.HW-D-0396 - Joint Systems

Design/System/Construction/Assembly Usage Disclaimer

- Authorities Having Jurisdiction should be consulted in all cases as to the particular requirements covering the installation and use of UL Certified products, equipment, system, devices, and materials.
- Authorities Having Jurisdiction should be consulted before construction.
- Fire resistance assemblies and products are developed by the design submitter and have been investigated by UL for compliance with applicable requirements. The published information cannot always address every construction nuance encountered in the field.
- When field issues arise, it is recommended the first contact for assistance be the technical service staff provided by the product manufacturer noted for the design. Users of fire resistance assemblies are advised to consult the general Guide Information for each product category and each group of assemblies. The Guide Information includes specifics concerning alternate materials and alternate methods of construction.
- Only products which bear UL's Mark are considered Certified.

## XHBN - Joint Systems

### XHBN7 - Joint Systems Certified for Canada

[See General Information for Joint Systems](#)

[See General Information for Joint Systems Certified for Canada](#)

#### System No. HW-D-0396

March 23, 2012

ANSI/UL2079	CAN/ULC S115
Assembly Ratings - 1 and 2 Hr (See Item 4)	F Ratings - 1 and 2 Hr (See Item 4)
Nominal Joint Width - 3/4 In.	FT Ratings - 1 and 2 Hr (See Item 4)
Class II Movement Capabilities — 17% Compression or Extension	FH Ratings - 1 and 2 Hr (See Item 4)
L Rating At Ambient — Less Than 1 CFM/in ft	FTH Ratings - 1 and 2 Hr (See Item 4)
L Rating At 400 F — Less Than 1 CFM/in ft	Nominal Joint Width - 3/4 In.
	Class II Movement Capabilities — 17% Compression or Extension
	L Rating At Ambient — Less Than 1 CFM/in ft
	L Rating At 400 F — Less Than 1 CFM/in ft

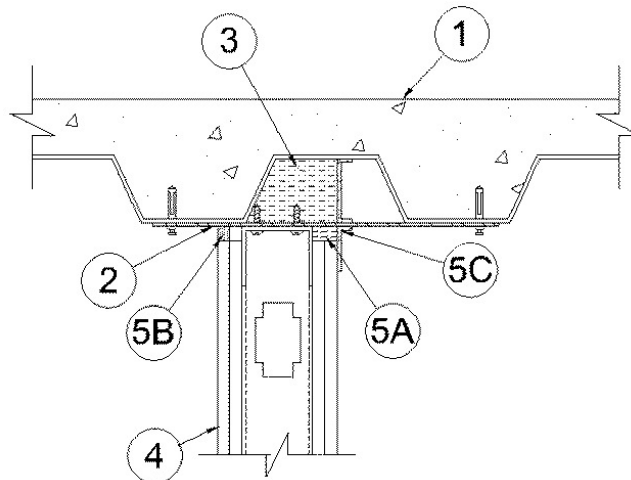

**1. Floor Assembly** — The fire-rated fluted steel floor unit/concrete floor assembly shall be constructed of the materials and in the manner described in the individual D900 Series Floor-Ceiling Design in the Fire Resistance Directory and shall include the following construction features:

- A. **Steel Floor and Form Units\*** — Max 3 in. (76 mm) deep galv steel fluted floor units.
- B. **Concrete** — Min 2-1/2 in. (64 mm) thick reinforced concrete, as measured from the top plane of the floor units.

**2. Steel Straps** — Min 2 in. (51 mm) wide min No. 16 gauge galv steel straps cut to a length to span the flute and overlap the adjacent valleys of fluted floor units by min 1-1/2 in. (38 mm). Straps spaced max 24 in. (610 mm) OC and fastened to floor assembly with masonry anchors or steel fastener.

**3. Forming Material\* - Plugs** — Preformed mineral wool plugs, formed to the shape of the fluted floor area directly above the wall, friction fit to fill the fluted area directly above the steel straps and wall. Adjacent lengths of plugs to be tightly butted with butted seams spaced min 24 in. (610 mm) apart along the length of the plugs.

**HILTI CONSTRUCTION CHEMICALS, DIV OF HILTI INC** — CP777 Speed Plugs

**4. Wall Assembly** — The 1 or 2 h fire rated gypsum board/stud wall assembly shall be constructed of the materials and in the manner specified in the individual U400, V400 or W400 Series Wall and Partition Design in the UL Fire Resistance Directory and shall include the following construction features:

- A. **Steel Floor and Ceiling Runners** — Floor and ceiling runners of wall assembly shall consist of min No. 25 gauge galv steel channels sized to accommodate steel studs (Item 2B). Flange height of ceiling runner shall be min 1/4 in. (6 mm) greater than max extended joint width. Ceiling runner installed parallel to direction of fluted steel floor units, directly beneath steel straps, and secured to straps with two No. 8 self-drilling, self-tapping steel screws per strap.

A1. **Light Gauge Framing\* - Slotted Ceiling Runner** — As an alternate to the ceiling runner in Item 4A, ceiling runner to consist of galv steel channel with slotted flanges sized to accommodate steel studs (Items 4B). Ceiling runner installed parallel to direction of fluted steel floor deck, directly beneath steel straps, and secured to straps with two No. 8 self-drilling, self-tapping steel screws per strap. When slotted ceiling runner is used, deflection channel (Item 3A) shall not be used.

**CALIFORNIA EXPANDED METAL PRODUCTS CO** — CST

**BRADY CONSTRUCTION INNOVATIONS INC, DBA SLIPTRACK SYSTEMS** — SLP-TRK

**MARINO/WARE, DIV OF WARE INDUSTRIES INC** — Type SLT

B. **Studs** — Steel studs to be min 3-1/2 in. (89 mm) wide. Studs cut 1/2 to 3/4 in. (13 to 19 mm) less in length than assembly height with bottom nesting in and resting on the floor runner and with top nesting in ceiling runner without attachment. When slotted ceiling runner (Item 4A1) is used, steel studs secured to slotted ceiling runner with No. 8 by 1/2 in. (13 mm) long wafer head steel screws at midheight of slot on each side of wall. Stud spacing not to exceed 24 in. (610 mm) OC.

C. **Gypsum Board\*** — For 1 hr assembly, one layer of 5/8 in. (16 mm) thick gypsum board as specified in the individual Wall and Partition Design. For 2 hr assembly, two layers of 5/8 in. (16 mm) thick gypsum board as specified in the individual Wall and Partition Design. For both hourly ratings, a nominal 3/4 in. (19 mm) gap shall be maintained between the top of the gypsum board and the bottom surface of the steel floor units and the bottom surface of the steel straps and forming material (Item 3). The top row of screws shall be installed into the studs 3 in. (76 mm) below the valleys of the steel floor units.

**The hourly fire rating of the joint system is equal to the hourly rating of the wall.**

**5. Joint System** — Max separation between bottom of floor and top of wall is 3/4 in. (19 mm). The joint system is designed to accommodate a max 17 percent compression or extension from its installed width. The joint system consists of a forming material and two fill materials between the top of the gypsum board and the bottom of the floor, as follows:

- A. **Forming Material\*** — Min 4 pcf (64 kg/m<sup>3</sup>) density mineral wool batt insulation shall be cut into strips to fill the gap between the top of the gypsum board and the underside of the forming material plugs (Item 3) and straps (Item 2) on the side of the wall located beneath the crest of the floor units. The width of the strips shall be equal to the total thickness of the gypsum board. The strips of mineral wool are compressed 50 percent in thickness and inserted cut-edge first into the gap between the top of the gypsum board and bottom of the mineral wool plug or steel straps.

**ROCK WOOL MANUFACTURING CO** — Delta Board

**ROCKWOOL** — SAFE

A1. **Forming Material\* - Strips** — As an alternate to Item 5A, nom 5/8 in. (16 mm) and 1-1/4 in. (32 mm) wide precut mineral wool strips for 1 and 2 hr rated assemblies respectively. The strips are compressed 50 percent in thickness and inserted cut-edge first into the gap between the top of the gypsum board and the underside of the forming material plugs (Item 3) and straps (Item 2) on the side of the wall located beneath the crest of the floor units. Adjoining lengths of strips to be tightly butted with butted seams spaced min 48 in. (1219 mm) apart along the length of the joint.

**HILTI CONSTRUCTION CHEMICALS, DIV OF HILTI INC** — CP 767 Speed Strips

A2. **Forming Material** — (Optional, Not Shown) - Mineral wool insulation, fiberglass batt insulation or polyurethane/polyethylene foam backer rod. Forming material to be installed on the side of the 2 hr fire rated wall located beneath valley of steel floor units, between the top of the gypsum board and the valley of the steel floor unit, and recessed from surface of the wall to accommodate the required thickness of sealant (Item 5B).

B. **Fill, Void or Cavity Material\* - Sealant** — Min 5/8 in. (16 mm) thickness of fill material installed on the side of the wall located beneath valley of steel floor unit, between the top of the gypsum board and the bottom of the valleys of the steel floor units, flush with the surface of the wall.

**HILTI CONSTRUCTION CHEMICALS, DIV OF HILTI INC** — CP606 Sealant

C. **Fill, Void or Cavity Material\* - Sealant** — Min 1/8 in. (3.2 mm) wet thickness ( min 1/16 in. or 1.6 mm dry thickness) of fill material sprayed or troweled to completely cover the mineral wool plugs (Item 3) and mineral wool forming material (Items 5A and 5A1) on the side of the wall located beneath the crest of the steel floor unit. Fill material to overlap a min of 1/2 in. (13 mm) onto the gypsum board, steel floor units and steel straps.

**HILTI CONSTRUCTION CHEMICALS, DIV OF HILTI INC** — CP672 Firestop Spray or CFS-SP WB Firestop Joint Spray

**\* Indicates such products shall bear the UL or cUL Certification Mark for jurisdictions employing the UL or cUL Certification (such as Canada), respectively.**

[Last Updated](#) on 2012-03-23

The appearance of a company's name or product in this database does not in itself assure that products so identified have been manufactured under UL's Follow-Up Service. Only those products bearing the UL Mark should be considered to be Certified and covered under UL's Follow-Up Service. Always look for the Mark on the product.

UL permits the reproduction of the material contained in the Online Certification Directory subject to the following conditions: 1. The Guide Information, Assemblies, Constructions, Designs, Systems, and/or Certifications (files) must be presented in their entirety and in a non-misleading manner, without any manipulation of the data (or drawings). 2. The statement "Reprinted from the Online Certifications Directory with permission from UL" must appear adjacent to the extracted material. In addition, the reprinted material must include a copyright notice in the following format: "© 2022 UL LLC"