

## XHBN.HW-D-0295 - Joint Systems

Design/System/Construction/Assembly Usage Disclaimer

- Authorities Having Jurisdiction should be consulted in all cases as to the particular requirements covering the installation and use of UL Certified products, equipment, system, devices, and materials.
- Authorities Having Jurisdiction should be consulted before construction.
- Fire resistance assemblies and products are developed by the design submitter and have been investigated by UL for compliance with applicable requirements. The published information cannot always address every construction nuance encountered in the field.
- When field issues arise, it is recommended the first contact for assistance be the technical service staff provided by the product manufacturer noted for the design. Users of fire resistance assemblies are advised to consult the general Guide Information for each product category and each group of assemblies. The Guide Information includes specifics concerning alternate materials and alternate methods of construction.
- Only products which bear UL's Mark are considered Certified.

## XHBN - Joint Systems

### XHBN7 - Joint Systems Certified for Canada

[See General Information for Joint Systems](#)

[See General Information for Joint Systems Certified for Canada](#)

#### System No. HW-D-0295

March 23, 2012

ANSI/UL2079	CAN/ULC S115
Assembly Ratings — 1, 2, 3 and 4 Hr (See Item 2)	F Ratings — 1, 2, 3 and 4 Hr (See Item 2)
Nominal Joint Width - 1 In.	FT Ratings — 1, 2, 3 and 4 Hr (See Item 2)
Class II Movement Capabilities — 12.5% Compression or Extension	FH Ratings — 1, 2, 3 and 4 Hr (See Item 2)
L Rating At Ambient — Less Than 1 CFM/lin ft	FTH Ratings — 1, 2, 3 and 4 Hr (See Item 2)
L Rating At 400 F — Less Than 1 CFM/lin ft	Nominal Joint Width - 1 In.
	Class II Movement Capabilities — 12.5% Compression or Extension
	L Rating At Ambient — Less Than 1 CFM/lin ft
	L Rating At 400 F — Less Than 1 CFM/lin ft

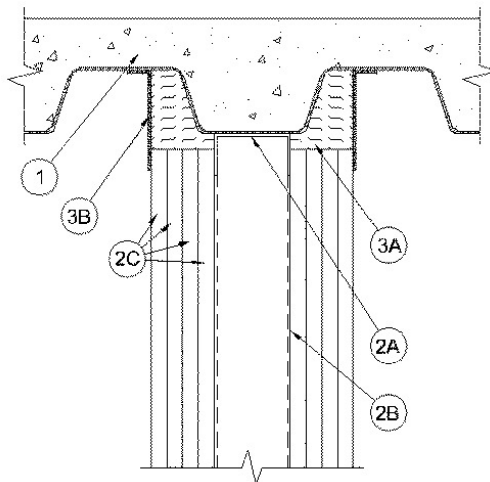

**1. Floor Assembly** — The fire-rated fluted steel floor unit/concrete floor assembly shall be constructed of the materials and in the manner described in the individual Floor-Ceiling Design in the Fire Resistance Directory. The hourly rating of the floor assembly shall be equal to or greater than the hourly rating of the wall assembly. The floor assembly shall include the following construction features:

**A. Steel Floor and Form Units\*** — Max 3 in. (76 mm) deep galv steel fluted floor units.

**B. Concrete** — Min 2-1/2 in. (64 mm) thick reinforced concrete, as measured from the top plane of the floor units.

**2. Wall Assembly** — The 1, 2, 3 or 4 h fire rated gypsum board/stud wall assembly shall be constructed of the materials and in the manner specified in the individual U400, V400 or W400 Series Wall and Partition Design in the UL Fire Resistance Directory and shall include the following construction features:

**A. Steel Floor and Ceiling Runners** — Floor and ceiling runners of wall assembly shall consist of min No. 25 gauge galv steel channels sized to accommodate steel studs (Item 2B). Flange height of ceiling runner shall be min 1/4 in. (6 mm) greater than max extended joint width. Ceiling runner installed parallel to and centered directly beneath valleys of fluted steel floor units and secured to valleys with steel fasteners or by welds spaced max 24 in. (610 mm) OC.

**A1. Light Gauge Framing\* - Slotted Ceiling Runner** — As an alternate to the ceiling runner in Item 2A, slotted ceiling runner to consist of galv steel channel with slotted flanges sized to accommodate steel studs (Item 2B). Slotted ceiling runner installed parallel to and centered directly beneath valleys of fluted steel floor units and secured to valleys with steel fasteners spaced max 24 in. (610 mm) OC.

**CALIFORNIA EXPANDED METAL PRODUCTS CO** — CST

**BRADY CONSTRUCTION INNOVATIONS INC, DBA SLIPTRACK SYSTEMS** — SLP-TRK

**MARINO/WARE, DIV OF WARE INDUSTRIES INC** — Type SLT

**A2. Light Gauge Framing\* - Vertical Deflection Ceiling Runner** — As an alternate to the ceiling runners in Item 2A and 2A1, vertical deflection ceiling runner to consist of galv steel channel with slotted vertical deflection clips mechanically fastened within runner. Slotted clips shall be maintained between top of gypsum board and the lower surface of the steel floor units. The screws attaching the gypsum board to the studs at the top of the first layer shall be located 4 in. (102 mm) from the steel floor unit valleys. The screws attaching the second layer to the steel studs shall be located 3-1/2 in. (89 mm) from the valleys of the steel floor units. The screws attaching the gypsum board to the studs at the top of the third layer shall be located 3 in. (76 mm) from the steel floor unit valleys. The screws attaching the fourth layer to the steel studs shall be located 2-1/2 in. (64 mm) from the valleys of the steel floor units.

**THE STEEL NETWORK INC** — VertTrack VTD358, VTD400, VTD600 and VTD800

**B. Studs** — Steel studs to be min 3-1/2 in. (89 mm) wide. Studs cut 1/2 in. (13 mm) to 3/4 in. (19 mm) less in length than assembly height with bottom nesting in and resting on the floor runner and with top nesting in ceiling runner without attachment. When slotted ceiling runner is used, steel studs secured to slotted ceiling runner with No. 8 by 1/2 in. (13 mm) long wafer head steel screws at midheight of slot on each side of wall. When vertical deflection ceiling runner is used, steel studs secured to slotted vertical deflection clips, through bushings, with steel screws at midheight of each slot. Stud spacing not to exceed 24 in. (610 mm) OC.

**C. Gypsum Board\*** — Nom 5/8 in. (16 mm) thick gypsum board with square or tapered edges. The gypsum board type, number of layers, fastener type and sheet orientation shall be as specified in the individual Wall and Partition Design, except that a nom 1 in. (25 mm) gap shall be maintained between top of gypsum board and the lower surface of the steel floor units. The screws attaching the gypsum board to the studs at the top of the first layer shall be located 4 in. (102 mm) from the steel floor unit valleys. The screws attaching the second layer to the steel studs shall be located 3-1/2 in. (89 mm) from the valleys of the steel floor units. The screws attaching the gypsum board to the studs at the top of the third layer shall be located 3 in. (76 mm) from the steel floor unit valleys. The screws attaching the fourth layer to the steel studs shall be located 2-1/2 in. (64 mm) from the valleys of the steel floor units.

**The hourly ratings of the joint system are dependent on the hourly rating of the wall.**

**3. Joint System** — Max separation between bottom of floor units and top of gypsum board at time of installation is 1 in. (25 mm). The joint system is designed to accommodate a max 12.5 percent compression or extension from its installed width. The joint system shall consist of a forming material and a fill material as follows:

**A. Forming Material\*** — Nom 4 pcf (64 kg/m<sup>3</sup>) density mineral wool batt insulation cut into strips having a width equal to the total thickness of gypsum board layers, to fill the gap between the top of the gypsum board and bottom of the steel deck. The strips of mineral wool are compressed 50 percent and tightly packed, cut edge first, into the gap on both sides of the wall.

**ROCK WOOL MANUFACTURING CO** — Delta Board

**ROCKWOOL** — SAFE

**THERMAFIBER INC** — Type SAF

B. **Fill, Void or Cavity Material\*** — Min 1/8 in. (3.2 mm) wet thickness (min 1/16 in. or 1.6 mm dry thickness) of fill material sprayed or troweled on each side of the wall to completely cover mineral wool forming material and to overlap a min of 1/2 in. (13 mm) onto gypsum board and steel deck on both sides of wall.  
HILTI CONSTRUCTION CHEMICALS, DIV OF HILTI INC — CP672 Firestop Spray or CFS-SP WB Firestop Joint Spray

**\* Indicates such products shall bear the UL or cUL Certification Mark for jurisdictions employing the UL or cUL Certification (such as Canada), respectively.**

[Last Updated](#) on 2012-03-23

---

The appearance of a company's name or product in this database does not in itself assure that products so identified have been manufactured under UL Solutions' Follow - Up Service. Only those products bearing the UL Mark should be considered to be Certified and covered under UL Solutions' Follow - Up Service. Always look for the Mark on the product.

UL Solutions permits the reproduction of the material contained in Product IQ subject to the following conditions: 1. The Guide Information, Assemblies, Constructions, Designs, Systems, and/or Certifications (files) must be presented in their entirety and in a non-misleading manner, without any manipulation of the data (or drawings). 2. The statement "Reprinted from Product IQ with permission from UL Solutions" must appear adjacent to the extracted material. In addition, the reprinted material must include a copyright notice in the following format: "©2022 UL LLC."