

XHBN.HW-D-0264 - Joint Systems

Design/System/Construction/Assembly Usage Disclaimer

- Authorities Having Jurisdiction should be consulted in all cases as to the particular requirements covering the installation and use of UL Certified products, equipment, system, devices, and materials.
- Authorities Having Jurisdiction should be consulted before construction.
- Fire resistance assemblies and products are developed by the design submitter and have been investigated by UL for compliance with applicable requirements. The published information cannot always address every construction nuance encountered in the field.
- When field issues arise, it is recommended the first contact for assistance be the technical service staff provided by the product manufacturer noted for the design. Users of fire resistance assemblies are advised to consult the general Guide Information for each product category and each group of assemblies. The Guide Information includes specifics concerning alternate materials and alternate methods of construction.
- Only products which bear UL's Mark are considered Certified.

XHBN - Joint Systems

XHBN7 - Joint Systems Certified for Canada

[See General Information for Joint Systems](#)

[See General Information for Joint Systems Certified for Canada](#)

System No. HW-D-0264

September 02, 2020

ANSI/UL2079	CAN/ULC S115
Assembly Ratings — 1 and 2 Hr (See Item 4)	F Ratings — 1 and 2 Hr (See Item 4)
Nominal Joint Width - 1-1/2 In.	FT Ratings — 1 and 2 Hr (See Item 4)
Class II Movement Capabilities — 50% Compression or Extension	FH Ratings — 1 and 2 Hr (See Item 4)
L Rating At Ambient — Less Than 1 CFM/in ft	FTH Ratings — 1 and 2 Hr (See Item 4)
L Rating At 400 F — Less Than 1 CFM/in ft	Nominal Joint Width - 1-1/2 In.
	Class II Movement Capabilities — 50% Compression or Extension
	L Rating At Ambient — Less Than 1 CFM/in ft
	L Rating At 400 F — Less Than 1 CFM/in ft

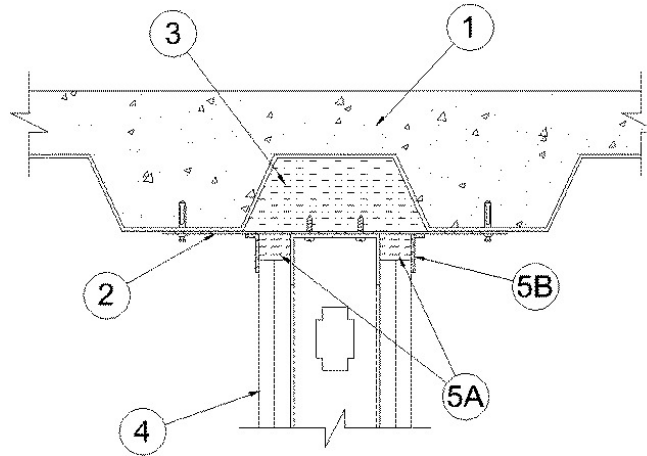

1. Floor Assembly — The fire-rated fluted steel floor unit/concrete floor assembly shall be constructed of the materials and in the manner described in the individual D700 or D900 Series Floor-Ceiling Design in the Fire Resistance Directory and shall include the following construction features:

- A. **Steel Floor and Form Units*** — Max 3 in. (76 mm) deep galv steel fluted floor units.
- B. **Concrete** — Min 2-1/2 in. (64 mm) thick reinforced concrete, as measured from the top plane of the floor units.
- C. **Spray-Applied Fire Resistive Material*** — (Optional. Not Shown) - After installation of the steel straps (Item 2), the steel floor units may be sprayed with the min thickness of material specified in the individual D700 Series Design.
ISOLATEK INTERNATIONAL — Type 300
- GCP APPLIED TECHNOLOGIES INC** — Types MK-6/HY or MK-10HB

1A. Roof Assembly — (Not Shown) - As an alternate to the floor assembly, a fire rated fluted steel deck roof assembly may be used. The roof shall be constructed of the materials and in the manner described in the individual P700 or P900 Series Roof-Ceiling designs in the UL Fire Resistance Directory. The hourly rating of the roof assembly shall be equal to or greater than the hourly rating of the wall assembly. The roof assembly shall include the following construction features:

- A. **Steel Roof Deck** — Max 3 in. (76 mm) deep galv steel fluted roof deck.
- B. **Roof Insulation** — Roof insulation to consist of min 2-1/4 in. (57 mm) thick poured insulating concrete, as measured from the top plane of the roof deck.
- C. **Spray-Applied Fire Resistive Material*** — (Optional. Not Shown) - After installation of the steel straps (Item 2), all surfaces of the steel deck may be sprayed with the thickness of material as specified in the individual P700 Series Floor-Ceiling Design. The flutes of the steel deck above the steel straps and wall may be filled with material as an alternate to the Forming Material (Item 3).
ISOLATEK INTERNATIONAL — Type 300
- GCP APPLIED TECHNOLOGIES INC** — Types MK-6/HY or MK-10HB

2. Steel Straps — Min. 2 in. (51 mm) wide 16 MSG galv steel straps cut to a length to span the flute and overlap the adjacent valleys of fluted floor units or roof deck by 1-1/2 in. (38 mm). Straps spaced max 24 in. (610 mm) OC and fastened to floor or roof assembly with masonry anchors or steel fasteners. As an alternate, min 1 in. (25 mm) long Hilti X-DNI 27 P8 S15 or Hilti X-U 27 P8 S15 powder actuated floor pins with integral min 9/16 in. (14 mm) diam washer may be used to secure steel straps to floor or roof assembly.

3. Forming Material* - Plugs — Preformed mineral wool plugs, formed to the shape of the fluted floor units or roof deck, friction fit to completely fill the flutes above the steel straps. Adjacent lengths of plugs to be tightly butted with butted seams spaced min 24 in. (610 mm) apart along the length of the plugs.
HILTI CONSTRUCTION CHEMICALS, DIV OF HILTI INC — CP777 Speed Plugs

3A. Forming Material* — As an alternate to Item 3, min 4 pcf (64 kg/m³) mineral wool batt insulation forming material cut to the shape of the fluted floor units or roof deck and friction fit to completely fill the flutes above the steel straps. Adjacent lengths of batts to be tightly butted with butted seams spaced min 24 in. (610 mm) apart along the length of the flutes.
INDUSTRIAL INSULATION GROUP L L C — MinWool-1200 Safing

JOHNS MANVILLE — Safing

ROCK WOOL MANUFACTURING CO — Delta Board

ROCKWOOL — SAFE

THERMAFIBER INC — Type SAF

4. **Wall Assembly** — The 1 hr or 2 h fire-rated gypsum board/stud wall assembly shall be constructed of the materials and in the manner specified in the individual U400, V400 or W400 Series Wall and Partition Design in the UL Fire Resistance Directory and shall include the following construction features:

A. **Steel Floor and Ceiling Runners** — Floor and ceiling runners of wall assembly shall consist of min No. 25 gauge galv steel channels sized to accommodate steel studs (Item 2B). Flange height of ceiling runner to be 3/4 in. (19 mm) greater than extended joint width. Ceiling runner installed parallel to direction of fluted steel floor units, directly beneath steel straps, and secured to straps with two No. 8 self-drilling, self-tapping steel screws per strap.

A1. **Light Gauge Framing* — Slotted Ceiling Runner** — As an alternate to the ceiling runner in Item 4A, ceiling runner to consist of galv steel channel with slotted flanges sized to accommodate steel studs (Items 4B). Ceiling runner installed parallel to direction of fluted steel floor deck, directly beneath steel straps, and secured to straps with two No. 8 self-drilling, self-tapping steel screws per strap. When slotted ceiling runner is used, deflection channel (Item 3A) shall not be used.

BRADY CONSTRUCTION INNOVATIONS INC, DBA SLIPTRACK SYSTEMS — SLP-TRK, SLPTRK325

CALIFORNIA EXPANDED METAL PRODUCTS CO — CST, CST325

CLARKDIETRICH BUILDING SYSTEMS — Types SLT, SLT-H

MARINO/WARE, DIV OF WARE INDUSTRIES INC — Type SLT

METAL-LITE INC — The System

RAM SALES L L C — RAM Slotted Track

A2. **Light Gauge Framing* - Notched Ceiling Runner** — As an alternate to the ceiling runners in Items 2A through 2A1, notched ceiling runners to consist of C-shaped galv steel channel with notched return flanges sized to accommodate steel studs (Item 2B). Notched ceiling runner installed perpendicular to direction of fluted steel deck and secured to valleys with steel masonry anchors spaced max 24 in. (610 mm) OC.

OLMAR SUPPLY INC — Type SCR

A3. **Light Gauge Framing* — Slotted Ceiling Runner** — As an alternate to the ceiling runner in Item 4A through 4A2, ceiling runner to consist of galv steel channel with slotted flanges sized to accommodate steel studs (Item 4B). Flange height of slotted ceiling runner shall be 3-1/4 in. (83 mm) with 2 in. (51 mm) deep slots. Slotted ceiling runner installed parallel to direction of fluted steel floor deck, directly beneath steel straps, and secured to straps with two No. 8 self-drilling, self-tapping steel screws per strap.

SCAFCO STEEL STUD MANUFACTURING CO — Slotted Track-Type SDLT

B. **Studs** — Steel studs to be min 2-1/2 in. (64 mm) wide. Studs cut 3/4 in. (19 mm) to 1 in. (25 mm) less in length than assembly height with bottom nesting in and resting on the floor runner and with top nesting in ceiling runner without attachment. When slotted ceiling runner (Item 4A1) is used, steel studs secured to slotted ceiling runner with No. 8 by 1/2 in. (13 mm) long wafer head steel screws at midheight of slot on each side of wall. Stud spacing not to exceed 24 in. (610 mm) OC. When slotted ceiling runner (Item 4A3) is used, steel studs cut in lengths 3/4 to 1-3/4 in. (19 to 44 mm) less than floor to ceiling height and secured to slotted ceiling runner with No. 8 by 1/2 (13 mm) long wafer head steel screws at +/- 3/16 in. (5 mm) of the mid-height of slot on each side of wall.

C. **Gypsum Board*** — For 1 hr assembly, one layer of 5/8 in. (16 mm) thick gypsum board as specified in the individual Wall and Partition Design. For 2 hr assembly, two layers of 5/8 in. (16 mm) thick gypsum board are specified in the individual Wall and Partition Design. For both hourly ratings, a nominal 1-1/2 in. (38 mm) gap shall be maintained between the top of the gypsum board and the bottom surface of the steel floor units and the top row of screws shall be installed into the studs 3 in. (76 mm) below the valleys of the steel floor units.

The hourly ratings of the joint system are dependent on the hourly rating of the wall.

5. **Joint System** — **Max separation between bottom of floor and top of wall is 1-1/2 in. (38 mm). The joint system is designed to accommodate a max 50percent compression or extension from its installed width.** The joint system consists of a forming material and a fill material between the top of the gypsum board and the bottom of the floor, as follows:

A. **Forming Material*** — Min 4 pcf (64 kg/m³) density mineral wool batt insulation cut shall be cut into strips to fill the gap between the top of gypsum board and bottom of the floor units. The width of the strips shall be equal to the total thickness of the gypsum board. The strips of mineral wool are compressed 50 percent in thickness and firmly packed into the gap between the top of the gypsum board and bottom of the mineral wool plug or steel floor units.

INDUSTRIAL INSULATION GROUP L L C — MinWool-1200 Safing

JOHNS MANVILLE — Safing

ROCK WOOL MANUFACTURING CO — Delta Board

ROCKWOOL — SAFE

THERMAFIBER INC — Type SAF

A1. **Forming Material* - Strips** — (Optional) - Nom 5/8 in. (16 mm) and 1-1/4 in. (32 mm) wide precut mineral wool strips for 1 hr and 2 hr rated assemblies respectively. The strips are compressed 50 percent in thickness and firmly packed into the gap between the top of the gypsum board and bottom of the steel floor units on both sides of the wall.

HILTI CONSTRUCTION CHEMICALS, DIV OF HILTI INC — CP 767 Speed Strips

B. **Fill, Void or Cavity Material* - Sealant** — Min 1/8 in. (3.2 mm) wet thickness (min 1/16 in. or 1.6 mm dry thickness) of fill material sprayed or troweled on each side of the wall to completely cover the mineral wool forming material and to overlap a min of 1/2 in. (13 mm) onto gypsum board, steel floor units or roof deck and steel straps on both sides of the wall and min 2 in. (51 mm) onto spray-applied fire resistive material (Item 1C).

HILTI CONSTRUCTION CHEMICALS, DIV OF HILTI INC — CFS-SP W8 Firestop Joint Spray

*** Indicates such products shall bear the UL or cUL Certification Mark for jurisdictions employing the UL or cUL Certification (such as Canada), respectively.**

[Last Updated](#) on 2020-09-02

The appearance of a company's name or product in this database does not in itself assure that products so identified have been manufactured under UL Solutions' Follow - Up Service. Only those products bearing the UL Mark should be considered to be Certified and covered under UL Solutions' Follow - Up Service. Always look for the Mark on the product.

UL Solutions permits the reproduction of the material contained in Product IQ subject to the following conditions: 1. The Guide Information, Assemblies, Constructions, Designs, Systems, and/or Certifications (files) must be presented in their entirety and in a non-misleading manner, without any manipulation of the data (or drawings). 2. The statement "Reprinted from Product IQ with permission from UL Solutions" must appear adjacent to the extracted material. In addition, the reprinted material must include a copyright notice in the following format: "©2022 UL LLC."