

XHBN.HW-D-0260 - Joint Systems

Design/System/Construction/Assembly Usage Disclaimer

- Authorities Having Jurisdiction should be consulted in all cases as to the particular requirements covering the installation and use of UL Certified products, equipment, system, devices, and materials.
- Authorities Having Jurisdiction should be consulted before construction.
- Fire resistance assemblies and products are developed by the design submitter and have been investigated by UL for compliance with applicable requirements. The published information cannot always address every construction nuance encountered in the field.
- When field issues arise, it is recommended the first contact for assistance be the technical service staff provided by the product manufacturer noted for the design. Users of fire resistance assemblies are advised to consult the general Guide Information for each product category and each group of assemblies. The Guide Information includes specifics concerning alternate materials and alternate methods of construction.
- Only products which bear UL's Mark are considered Certified.

XHBN - Joint Systems

[See General Information for Joint Systems](#)

System No. HW-D-0260

September 02, 2016

Assembly Ratings — 1 and 2 Hr (See Item 2)

Nominal Joint Width — 3/4 In.

L Rating At Ambient — Less Than 1 CFM/Lin Ft

L Rating At 400°F — Less Than 1 CFM/Lin Ft

Class II Movement Capabilities — 33% Compression or Extension

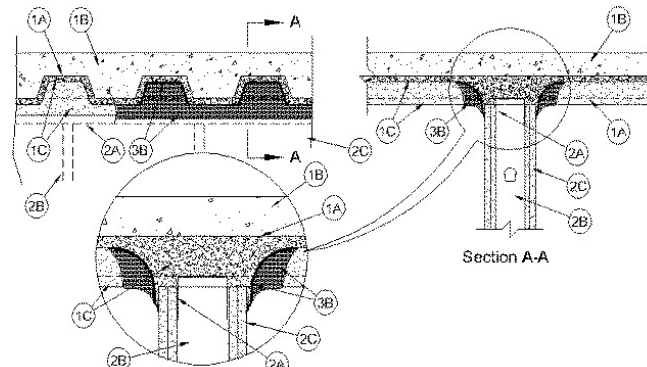

1. **Floor Assembly** — The fluted steel deck/concrete floor assembly shall be constructed of the materials and in the manner described in the individual Floor-Ceiling Design in the UL Fire Resistance Directory and shall include the following construction features:

A. **Steel Floor and Form Units*** — Max 3 in. (76 mm) deep galv fluted units.

B. **Concrete** — Min 2-1/2 in. (57 mm) thick reinforced concrete, as measured from the top plane of the floor units.

C. **Spray-Applied Fire Resistive Material*** — After installation of the ceiling runner (Item 2A) or deflection channel (Item 3A), all surfaces of the steel floor units to be sprayed with the thickness of material specified in the individual D700 or D800 Series Design. Spray-applied fire resistive material applied to completely fill the flutes of the steel floor units above the wall and to completely fill the gap above the gypsum board (Item 2C) on both sides of the wall assembly. The material is to lap a min of 1 in. (25 mm) onto the gypsum board.

ISOLATEK INTERNATIONAL — Type 300 or Type II

GCP APPLIED TECHNOLOGIES INC — Type MK-6/HY

1A. **Roof Assembly - (Not Shown)** — As an alternate to the floor assembly, a fire-rated fluted steel deck roof assembly may be used. The roof assembly shall be constructed of the materials and in the manner described in the individual P700 or P800 Series R roof-Ceiling Design in the UL Fire Resistance Directory. The hourly rating of the roof assembly shall be equal to or greater than the hourly rating of the wall assembly.

A. **Steel Roof Deck** — Max 3 in. (76 mm) deep galv steel fluted roof deck.

B. **Roof Insulation** — As specified in the individual P700 Series Design.

C. **Spray-Applied Fire Resistive Material*** — After installation of the ceiling runner (Item 2A) or deflection channel (Item 3A), the steel roof deck shall be sprayed with the thickness of material specified in the individual P700 or P800 Series Design. Spray-applied fire resistive material applied to completely fill the flutes of the steel roof deck above the wall and to completely fill the gap above the gypsum board (Item 2C) on both sides of the wall assembly. The material is to lap a min of 1 in. (25 mm) onto the gypsum board.

ISOLATEK INTERNATIONAL — Type 300 or Type II

GCP APPLIED TECHNOLOGIES INC — Type MK-6/HY

2. **Wall Assembly** — The 1 or 2 hr fire-rated gypsum board/steel stud wall assembly shall be constructed of the materials and in the manner described in the individual U400- or V400 Series Wall and Partition Design in the UL Fire Resistance Directory. The wall assembly shall include the following construction features:

A. **Steel Floor and Ceiling Runners** — Floor and ceiling runners of wall assembly shall consist of galv steel channels sized to accommodate steel studs (Item 2B). When U-shaped deflection channel (Item 3A) is used, ceiling runner installed within the deflection channel with 3/4 to 1 in. (19 to 25 mm) gap maintained between the top of ceiling runner and top of deflection channel. When deflection channel is not used, ceiling runner installed perpendicular to direction of the fluted steel floor or roof deck prior to application of the spray-applied fire resistive material and secured to valleys of fluted steel floor or roof deck with steel fasteners or welds spaced max 24 in. (610 mm) OC.

A1. **Light Gauge Framing* - Slotted Ceiling Runner** — When the thickness of spray-applied fire resistive material does not exceed 1 in. (25 mm), slotted ceiling runner maybe used as an alternate to the ceiling runner in Item 2A. Slotted ceiling runner to consist of galv steel channel with slotted flanges sized to accommodate steel studs (Item 2B). Slotted ceiling runner installed perpendicular to direction of fluted steel floor units or roof deck prior to the application of spray-applied fire resistive material and secured to valleys with steel fasteners spaced max 24 in. (610 mm) OC. When slotted ceiling runner is used deflection channel (Item 3A) shall not be used.

BRADY CONSTRUCTION INNOVATIONS INC, DBA SLIPTRACK SYSTEMS — SLP-TRK

CALIFORNIA EXPANDED METAL PRODUCTS CO — CST

CLARKDIETRICH BUILDING SYSTEMS — Type SLT, SLT-H

MARINO/WARE, DIV OF WARE INDUSTRIES INC — Type SLT

METAL-LITE INC — The System

RAM SALES L L C — RAM Slotted Track

SCAFCO STEEL STUD MANUFACTURING CO

TELLING INDUSTRIES L L C — True-Action Deflection Track

B. **Steel Studs** — Studs to be min 3-1/2 in. (89 mm) wide. Studs cut 1/2 to 3/4 in. (13 to 19 mm) less in length than assembly height. When deflection channel (Item 3A) is used, studs attached to ceiling runner (Item 2A) with sheet metal screws a min of 1/2 in. (13 mm) below bottom of deflection channel. When deflection channel is not used, studs shall not be secured to ceiling runner. When slotted ceiling runner is used, studs secured to slotted ceiling runner with No. 8 by 1/2 in. (13 mm) long wafer head steel screws at midheight of slot on each side of wall. Stud spacing not to exceed 24 in. (610 mm) OC.

C. **Gypsum Board*** — Gypsum board sheets installed to a min total thickness of 5/8 in. (16 mm) and 1-1/4 in. (32 mm) on each side of wall for 1 and 2 hr rated assemblies, respectively. Wall to be constructed as specified in the individual Wall and Partition Design in the UL Fire Resistance Directory except that a nom 3/4 in. (19 mm) gap shall be maintained between the top of the gypsum board and the bottom of the steel floor or roof deck. The screws attaching the gypsum board to studs (Item 2B) at the top of the wall shall be located 1 in. (25 mm) below the bottom of the ceiling runner (Item 2A), U-shaped deflection channel (Item 3A) or slotted ceiling runner (Item 2A1). **The hourly fire rating of the joint system is equal to the hourly fire rating of the wall.**

3. **Joint System Max separation between bottom of steel floor or roof deck and top of wall is 3/4 in. (19 mm). The joint system is designed to accommodate a max 33 percent compression or extension from its installed width.** — The joint system consists of a fill material, with or without a deflection channel (Item 3A), as follows:

A. **Deflection Channel** — (Optional, Not Shown) - Nom 3 in. (76 mm) deep by min 25 gauge galv steel U-shaped channel sized to accommodate ceiling runner (Item 2A). Deflection channel installed perpendicular to direction of the fluted steel floor or roof deck prior to application of the sprayed-applied fire resistive material and secured with steel fasteners or welds spaced max 24 in. (610 mm) OC. The ceiling runner (Item 2A) is installed within the deflection channel to maintain a 3/4 to 1 in. (19 to 25 mm) gap between the top of the ceiling runner and the top of the deflection channel. The ceiling runner is not fastened to the deflection channel.

B. **Fill, Void or Cavity Material*** — Min 1/8 in. (3.2 mm) wet thickness (min 1/16 in. or 1.6 mm dry thickness) of fill material sprayed to completely cover radius of spray-applied fire resistive material at the deck/wall interface and to lap a min of 1/2 in. (13 mm) onto the gypsum board (Item 2C) on both sides of wall assembly.
SPECIFIED TECHNOLOGIES INC — SpecSeal AS200 Elastomeric Spray

*** Indicates such products shall bear the UL or cUL Certification Mark for jurisdictions employing the UL or cUL Certification (such as Canada), respectively.**

Last Updated on 2016-09-02

The appearance of a company's name or product in this database does not in itself assure that products so identified have been manufactured under UL Solutions' Follow - Up Service. Only those products bearing the UL Mark should be considered to be Certified and covered under UL Solutions' Follow - Up Service. Always look for the Mark on the product.

UL Solutions permits the reproduction of the material contained in Product iQ subject to the following conditions: 1. The Guide Information, Assemblies, Constructions, Designs, Systems, and/or Certifications (files) must be presented in their entirety and in a non-misleading manner, without any manipulation of the data (or drawings). 2. The statement "Reprinted from Product iQ with permission from UL Solutions" must appear adjacent to the extracted material. In addition, the reprinted material must include a copyright notice in the following format: "©2022 UL LLC."