

XHBN.HW-D-0243 - Joint Systems

Design/System/Construction/Assembly Usage Disclaimer

- Authorities Having Jurisdiction should be consulted in all cases as to the particular requirements covering the installation and use of UL Certified products, equipment, system, devices, and materials.
- Authorities Having Jurisdiction should be consulted before construction.
- Fire resistance assemblies and products are developed by the design submitter and have been investigated by UL for compliance with applicable requirements. The published information cannot always address every construction nuance encountered in the field.
- When field issues arise, it is recommended the first contact for assistance be the technical service staff provided by the product manufacturer noted for the design. Users of fire resistance assemblies are advised to consult the general Guide Information for each product category and each group of assemblies. The Guide Information includes specifics concerning alternate materials and alternate methods of construction.
- Only products which bear UL's Mark are considered Certified.

XHBN - Joint Systems

[See General Information for Joint Systems](#)

System No. HW-D-0243

September 01, 2016

Assembly Ratings — 1 and 2 Hr (See Item 2)

Joint Width — 3/4 in. Max

Class II Movement Capabilities — 33% Compression

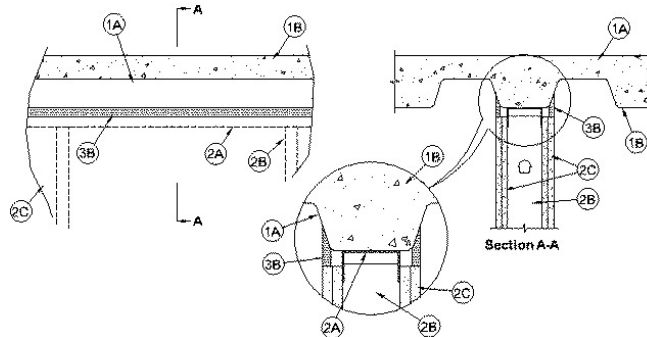

1. **Floor Assembly** — The fire-rated fluted steel deck/concrete floor assembly shall be constructed of the materials and in the manner described in the individual D900 Series Floor-Ceiling Design in the UL Fire Resistance Directory and shall include the following construction features:

A. **Steel Floor And Form Units*** — Max 3 in. (76 mm) deep galv steel fluted floor units having a min valley width of 4-3/4 in. (121 mm).

B. **Concrete** — Min 2-1/2 in. (64 mm) thick reinforced concrete, as measured from the top plane of the floor units.

- 1A. **Roof Assembly** — (Not Shown) — As an alternate to the floor assembly (Item 1), a fire rated fluted steel deck roof assembly may be used. The roof assembly shall be constructed of the materials and in the manner described in the individual P900 Series Roof-Ceiling Design in the UL Fire Resistance Directory. The hourly fire rating of the roof assembly shall be equal to or greater than the hourly fire rating of the wall assembly. The roof assembly shall include the following construction features:

A. **Steel Roof Deck** — Max 3 in. (76 mm) deep galv steel fluted roof deck having a min valley width of 4-3/4 in. (121 mm).

B. **Roof Insulation** — Min 2-1/4 in. (57 mm) thick poured insulating concrete, as measured from the top plane of the steel roof deck.

2. **Wall Assembly** — The 1 or 2 hr fire-rated gypsum board/stud wall assembly shall be constructed of the materials and in the manner described in the individual U400 or V400 Series Wall and Partition Design in the UL Fire Resistance Directory and shall include the following construction features:

A. **Steel Floor And Ceiling Runners** — Floor and ceiling runners of wall assembly shall consist of galv steel channels sized to accommodate steel studs. When deflection channel (Item 3A) is used, ceiling runner to be provided with min 2 in. (51 mm) flanges. Ceiling runner installed within the deflection channel with a 1/2 to 3/4 in. (13 to 19 mm) gap maintained between the top of the ceiling runner and the top of the deflection channel. When deflection channel is not used, flange height of ceiling runner shall be min 1/2 in. (13 mm) greater than nom joint width. Ceiling runner installed parallel with steel floor or roof deck, centered on steel deck valley, and secured with steel fasteners or welds spaced max 24 in. (610 mm) OC.

A1. **Light Gauge Framing* — Slotted Ceiling Runner** — As an alternate to the ceiling runner in item 2A, ceiling runner to consist of galv steel channel with slotted flanges sized to accommodate steel studs (Items 2B). Slotted ceiling runner installed parallel with steel floor or roof deck, centered on valley, and secured with steel fasteners or welds spaced max 24 in. (610 mm) OC. When slotted ceiling runner is used, deflection channel (Item 3A) shall not be used.

BRADY CONSTRUCTION INNOVATIONS INC, DBA SLIPTRACK SYSTEMS — SLP-TRK

CALIFORNIA EXPANDED METAL PRODUCTS CO — CST

CLARKDIETRICH BUILDING SYSTEMS — Type SLT, SLT-H

MARINO/WARE, DIV OF WARE INDUSTRIES INC — Type SLT

RAM SALES L L C — RAM Slotted Track

SCAFCO STEEL STUD MANUFACTURING CO

TELLING INDUSTRIES L L C — True-Action Deflection Track

B. **Studs** — Steel studs to be min 3-1/2 in. (89 mm) wide. Studs cut 1/2 to 3/4 in. (13 to 19 mm) less in length than assembly height with bottom nesting in and secured to floor runner. When deflection channel (Item 3A) is used, steel studs attached to ceiling runner with sheet metal screws located 1/2 in. (13 mm) below the bottom of the deflection channel. When deflection channel is not used, studs to nest in ceiling runner without attachment. When slotted ceiling runner (Item 2A1) is used, steel studs secured to slotted ceiling runner with No. 8 by 1/2 in. (13 mm) long wafer head steel screws at midheight of slot on each side of wall. Stud spacing not to exceed 24 in. (610 mm) OC.

C. **Gypsum Board*** — Gypsum board sheets installed to a min total thickness of 5/8 in. (16 mm) and 1-1/4 in. (32 mm) on each side of wall for 1 and 2 hr fire rated assemblies, respectively. Wall to be constructed as specified in the individual Wall and Partition Design in the UL Fire Resistance Directory, except that a nom 3/4 in. (19 mm) gap shall be maintained between the top of the gypsum board and the bottom surface of the steel floor units. In addition, the top row of screws shall be installed into the steel studs 1/2 to 1 in. (13 to 25 mm) below the bottom edge of the ceiling runner flange.

The hourly fire rating of the joint system is equal to the hourly fire rating of the wall assembly in which it is installed.

3. **Joint System** — Max separation between bottom of floor or roof deck and top of wall is 3/4 in. (19 mm) . The joint system is designed to accommodate a max 33 percent compression from its installed width. The joint system consists of the following:

A. **Deflection Channel** — Max 2 in. (51 mm) deep min 24 gauge galv steel channel sized to accommodate ceiling runner (Item 2A). Deflection channel centered on valley of fluted steel floor or roof deck and secured with steel fasteners or welds spaced max 24 in. (610 mm) OC. The ceiling runner is installed within the deflection channel to maintain a 1/2 to 3/4 in. (13 to 19 mm) gap between the top of the ceiling runner and the top of the deflection channel. The ceiling runner is not fastened to the deflection channel.

B. **Forming Material** — (Optional, Not Shown) — In 2 hr fire rated wall assemblies, foam backer rod friction fit into joint opening and recessed min 1/2 in. (13 mm) from each surface of wall.

C. **Fill, Void or Cavity Material* — Sealant** — Min 1/2 in. (13 mm) thickness of fill material applied within joint opening on both sides of wall, flush with both surfaces of wall. In 1 hr fire rated walls, bond breaker tape applied to ceiling channel (Item 2A) or deflection channel (Item 3A) prior to installation of fill material.

SPECIFIED TECHNOLOGIES INC — SpecSeal LCI Sealant

*** Indicates such products shall bear the UL or cUL Certification Mark for jurisdictions employing the UL or cUL Certification (such as Canada), respectively.**

[Last Updated](#) on 2016-09-01

The appearance of a company's name or product in this database does not in itself assure that products so identified have been manufactured under UL's Follow-Up Service. Only those products bearing the UL Mark should be considered to be Certified and covered under UL's Follow-Up Service. Always look for the Mark on the product.

UL permits the reproduction of the material contained in the Online Certification Directory subject to the following conditions: 1. The Guide Information, Assemblies, Constructions, Designs, Systems, and/or Certifications (files) must be presented in their entirety and in a non-misleading manner, without any manipulation of the data (or drawings). 2. The statement "Reprinted from the Online Certifications Directory with permission from UL" must appear adjacent to the extracted material. In addition, the reprinted material must include a copyright notice in the following format: "© 2022 UL LLC"