



Expanding Your Solutions



ViperStud® Product Catalog

Interior Non-Load Bearing Studs and Track



The Proprietary Steel Framing System That Has Withstood the Test of Time ...

A Track Record You Can Count On, Verified Code Compliant

By providing a lighter, stronger, more efficient framing system, ViperStud® has earned the trust of industry leaders nationwide. Made from high-strength steel and formed with exclusive ViperRib technology, ViperStud® is the flat steel system that will be here for the long term, you can count on that.

Code Information

ViperStud Drywall Framing has been verified by the following IAS Accredited Test Agencies and/or certified by the Product Evaluation Agencies listed here.



Patents ViperStud Patent #D621,964
ViperTrack Patent #D621,963

IBC/IRC 2012/2015/2018/2021 Compliant

ViperStud complies with 2015 ICC-ES code compliance certification programs. Please see the full versions of these reports at www.cemcosteel.com.

U.S. Patent Nos. D621,964 and D621,963 are assigned to Ware Industries, Inc. and used by CEMCO under license from Ware Industries, Inc. "ViperStud®", "ViperTrack®", and "ViperRib®" are registered trademarks of Ware Industries, Inc. The ViperStud logo and "Standing Strong™" are trademarks of Ware Industries, Inc. The "ViperStud®", "ViperTrack®", "ViperRib®" and "Standing Strong™" trademarks are used by CEMCO under license from Ware Industries, Inc. ©2011 Ware Industries, Inc. All rights reserved.

ViperStud Drywall Framing System is tested or conforms to these standards:

- **AISI S100-16/S2-20** North American Specification for the Design of Cold-Formed Steel Structural Members
- **AISI S220** North American Standard for Cold-Formed Steel Framing—Non-Structural Members
- **ASTM A1003** Standard Specification for Steel Sheet, Carbon, Metallic- and Nonmetallic Coated for Cold-Formed Framing Members
- **ASTM C645** Standard Specification for Nonstructural Steel Framing Members
- **ASTM A653/A653M** Standard Specification for Steel Sheet, Zinc-Coated (Galvanized) or Zinc-Iron Alloy-Coated (Galvannealed) by the Hot-Dip Process
- **ASTM C754** Standard Specification for Installation of Steel Framing Members to Receive Screw-Attached Gypsum Panel Products
- **ASTM E90** Standard Test Method for Laboratory Measurement of Airborne Sound Transmission Loss of Building Partitions and Elements
- **ASTM E119** Standard Test Methods for Fire Tests of Building construction and Materials. Fire rated for 1, 2, 3, and 4 hour rated walls.
- **ASTM E72** Standard Test Methods of Conducting Strength Tests of Panels for Building Construction
- **ASTM C1629** Standard Classification for Abuse-Resistant Non-decorated Interior Gypsum Panel Products and Fiber-Reinforced Cement Panels

ViperStud is listed in the following:

- ICC-ES ESR-2620
- NYC Department of Buildings MEA 56-08-M, MEA 56-08-M Vol 2, MEA 235-08-M

Architectural Testing Approved & ICC ES Code Compliant

Viper25, Viper20, Viper 30mil, and Viper 33mil manufactured by CEMCO received an evaluation report (ESR# 2620) from ICC Evaluation Service (ICC-ES), providing evidence that the ViperStud Drywall Framing System meets code requirements. Building officials, architects, contractors, specifiers, designers and others utilize these Evaluation Reports to provide a basis for using or approving metal

framing in construction projects following the International Building Code.

LEED v4 for Building & Design Construction

- MR Prerequisite: Construction and Demolition Waste Management Planning
- MR Credit: Construction and Demolition Waste Management
- MR Credit: Building Product Disclosure and Optimization—Sourcing of Raw Materials, Option 2
- MR Credit: Building Product Disclosure and Optimization—Material Ingredients, Option 1
- MR Credit: Building Life-Cycle Impact Reduction, Option 4

Recycled Content

- Total Recycled Content: 36.9%
- Post-Consumer: 19.8%
- Pre-Consumer: 14.4%

California's Proposition 65 Warning

California's Safe Drinking Water and Toxic Enforcement Act of 1986 – commonly referred to as Proposition 65 ("Prop 65") (27 Cal. Code Reg. § 25600, et seq.) – has recently changed, requiring manufacturers to provide a warning based on its knowledge about the presence of one or more of the almost 900 listed chemicals which are known to the State of California to cause cancer and birth defects, or other reproductive harm. With a few exceptions, manufacturers operating in the state of California as well as those entities who distribute, import, package, and/or supply products into the State of California are now required provide a "clear and reasonable" warning to consumers that their products may contain one or more of these listed chemicals or compounds. The complete list is available at www.P65Warnings.ca.gov.

In compliance with the new requirements, we are notifying each of our customers that CEMCO products contain Nickel (metallic) and/or other chemicals listed which are known to the State of California to cause cancer and birth defects or other reproductive harm. Safety data sheets from our major suppliers are available from CEMCO on our website at www.cemcosteel.com.

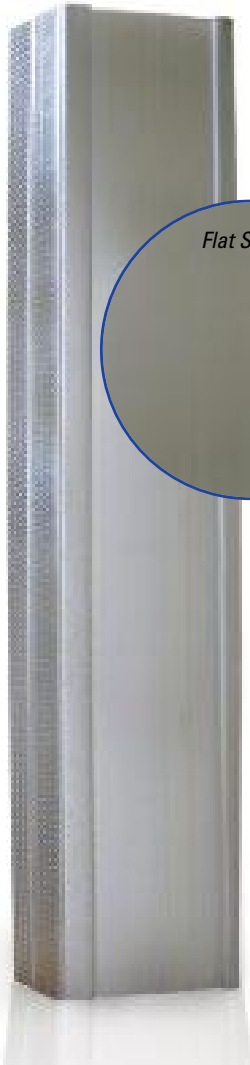

A High Strength, Flat Steel Drywall Framing System

The ViperStud® Drywall Framing System offers all the benefits of conventional flat steel studs with a design that performs even better. The ViperStud® drywall framing system is interchangeable with conventional framing components. Since ViperStud® is flat steel, it is easy to plumb and mark, make minor adjustments and use laser levels. This makes installation the same as conventional studs. No extra training or special fasteners are required for installation.

Knurl & Rib Technology

The stud and track system utilizes a knurled flange and reinforcing ribs along with a flat stud design. Knurling is the pattern of small ridges formed on the flange to prevent screws from walking. Since knurling is only formed on one side of the steel, the stud stays flat, never compromising the strength or thickness of the steel.

ViperRib® technology applies a reinforced ribbing over the web and flange of ViperStud. The ribs provide added strength, are less prone to twist and creating "high-shoulders" when finishing gypsum board.

ViperRib® Technology makes ViperStud stronger & less prone to twist or buckle.

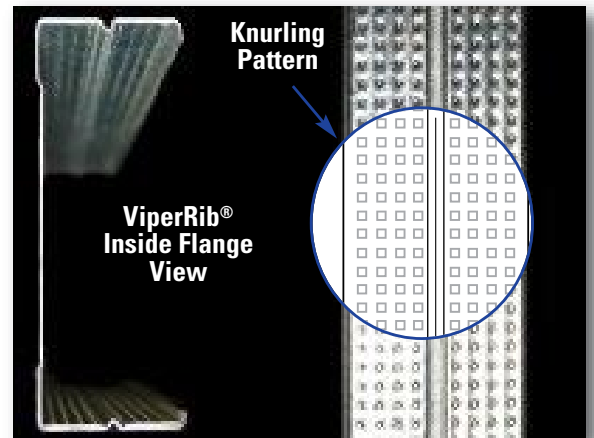
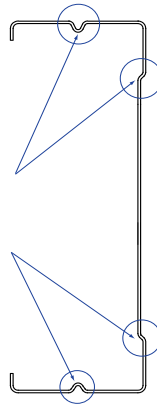

The One-Track System

We've tested ViperTrack25 extensively with Viper25 studs. Our third-party testing proves that it is not necessary to use the same thickness track as the stud. Now you can submit a lighter gauge track with your Viper20 studs and reduce your cost.

- Saves money
- Fewer items to inventory
- Supported by testing

Not applicable for Impact or Abuse Rated walls. Fire rated walls should be built per specific assembly requirements.



PHYSICAL PROPERTIES



ViperStud®

MODEL NO.	DESIGN THICKNESS (in)	MINIMUM THICKNESS (in)	YIELD (ksi)	WEB SIZES (in)	COATING ^{1,2}	FLANGE (in)	RETURN LIP
VIPER25	0.0155	0.0147	50	1-5/8, 2-1/2, 3-5/8, 4, 6	G40	1-1/4	1/4
*VIPER 18mil	0.0188	0.0179	33	1-5/8, 2-1/2, 3-5/8, 4, 6	G40	1-1/4	1/4
VIPER20	0.0190	0.0181	70	1-5/8, 2-1/2, 3-5/8, 4, 6	G40	1-1/4	VARIOUS
VIPER 30mil	0.0312	0.0296	33	1-5/8, 2-1/2, 3-5/8, 4, 6	G40	1-1/4	1/4
VIPER 33mil	0.0346	0.0329	33	1-5/8, 2-1/2, 3-5/8, 4, 6	G40	1-1/4	1/4

ViperTrack®

MODEL NO.	DESIGN THICKNESS (in)	MINIMUM THICKNESS (in)	YIELD (ksi)	WEB SIZES (in)	COATING ^{1,2}	FLANGE (in)
VIPERTRACK25	0.0155	0.0147	50	1-5/8, 2-1/2, 3-5/8, 4, 6	G40	1-1/4
*VIPERTRACK 18mil	0.0188	0.0179	33	1-5/8, 2-1/2, 3-5/8, 4, 6	G40	1-1/4
VIPERTRACK20	0.0190	0.0181	50	1-5/8, 2-1/2, 3-5/8, 4, 6	G40	1-1/4
VIPERTRACK 30mil	0.0312	0.0296	33	1-5/8, 2-1/2, 3-5/8, 4, 6	G40	1-1/4
VIPERTRACK 33mil	0.0346	0.0329	33	1-5/8, 2-1/2, 3-5/8, 4, 6	G40	1-1/4

Notes:

1. Per ASTM C645 & ASTM A1003 Table 1.
 2. G60 and G90 available upon request.
 3. Knockout size for 1-5/8" & 2-1/2" stud is 3/4" x 1-3/4".
Knockout size for 3-5/8", 4", and 6" stud is 1-1/2" x 2-1/2".
- *For Select Markets Only

Viper25 (15 mil) is equivalent to conventional 25 gauge (18 mil) studs, and Viper20 (18 mil/70 ksi) is equivalent to conventional 20 gauge studs (30 mil). ASTM C 645 Section 5.1 allows for permissible dimensional thickness variations. Section 8.2 allows for thickness variations and exemptions from minimum section property values, if specified performance requirements are not met. The ViperStud Drywall Framing products meet and exceed these requirements.



DEEP LEG DEFLECTION TRACK

Deflection track can be required at the top of a wall to allow for anticipation downward movement of the primary structure. A gap is provided between the end of the stud and track to accommodate this movement. The studs are not fastened to the track to allow movement up or down. The bridging is required within 12" from the top to keep the stud in place and provide rotational restraint. The leg of the track must be long enough to provide the required gap, bearing surface for the studs and allow for construction tolerances.

MODEL NO.	DESIGN THICKNESS (in)	MINIMUM THICKNESS (in)	YIELD (ksi)	COATING ^{4,5}	WEB SIZES (in) ²	LEG SIZE (in)	GAP (in)	LOAD (lb.)	MAX HEIGHT (5 psf, 16" o.c.)
VIPERTRACK25	0.0155	0.0147	50	G40	1-5/8, 2-1/2, 3-5/8, 4, 6	2"	1/2"	34	10'-4"
*VIPERTRACK18mil	0.0188	0.0179	33	G40	1-5/8, 2-1/2, 3-5/8, 4, 6	2"	1/2"	33	9' 11"
VIPERTRACK20	0.0190	0.0181	70	G40	1-5/8, 2-1/2, 3-5/8, 4, 6	2"	1/2"	72	21' 6"
					2-1/2, 3-5/8, 4, 6	2-1/2"	3/4"	48	14'-4"
					2-1/2, 3-5/8, 4, 6	3"	1"	36	10'-9"
VIPERTRACK 30mil	0.0312	0.0296	33	G40	1-5/8, 2-1/2, 3-5/8, 4, 6	2"	1/2"	92	27'-6"
					2-1/2, 3-5/8, 4, 6	2-1/2"	3/4"	61	18'-4"
					2-1/2, 3-5/8, 4, 6	3"	1"	46	13'-9"
VIPERTRACK 33mil	0.0346	0.0329	33	G40	1-5/8, 2-1/2, 3-5/8, 4, 6	2"	1/2"	113	33'-10"
					2-1/2, 3-5/8, 4, 6	2-1/2"	3/4"	75	22'-7"
					2-1/2, 3-5/8, 4, 6	3"	1"	56	16'-11"

Notes:

1. Max wall height based on track capacity and specified gap.
2. Wall height may also be limited by stud member. Check stud height separately of track capacity.
3. 1-5/8" deep leg track available with max 2" leg.
4. Wall studs are not fastened to deep leg track.
5. G60, G90 available upon request.
6. Coating per ASTM C645 & ASTM A 1003, Table 1.

* For Select Markets Only

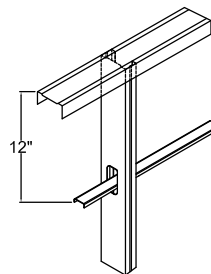

A. ALTERNATIVE 1
WITH CRC CHANNEL AND BRC CLIP. 12" DOWN FROM THE STUD END.

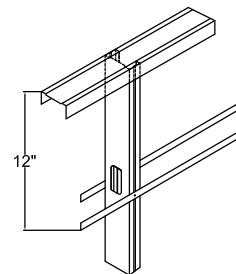

B. ALTERNATIVE 2
ATTACHING FLAT STRAP AT EACH SIDE OF THE STUD FLANGE. 12" DOWN FROM THE STUD END.

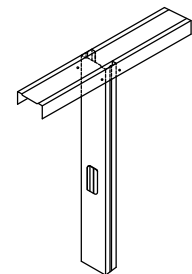

C. ALTERNATIVE 3
ATTACHING 2 SCREWS AT EACH LEG OF THE DEEP LEG TRACK, NEAR THE STUD FLANGES. (TOTAL 4 SCREWS)





SECTION PROPERTIES

VIPERSTUD®

MODEL NO.	GAUGE (mils)	MEMBER	DESIGN (in)	MIN. (in)	YIELD (ksi)	WEIGHT (lb/ft)	GROSS PROPERTIES					EFFECTIVE PROPERTIES		MOMENTS				CRITICAL UNBRACED LENGTH (in)
							AREA (in²)	I _x (in⁴)	R _x (in)	I _y (in⁴)	R _y (in)	I _{xd} (in⁴)	S _x (in³)	Allowable Moment Ma (in-k)	Local Buckling Nominal Moment Mnl (in-k)	Distortional Buckling Nominal Moment Mnd (in-k)	Nominal Moment for Conventional Studs Mn (in-k)	
VIPER25	25EQ (15)	162VS125-15 (25EQ)	0.0155	0.0147	50	0.24	0.071	0.032	0.671	0.0000	0.461	0.032	0.024	0.66	1.42	1.20	1.02 (18MIL)	25.1
		250VS125-15 (25EQ)	0.0155	0.0147	50	0.29	0.085	0.084	0.998	0.0170	0.452	0.090	0.042	1.17	2.72	2.12	1.72 (18MIL)	24.8
		362VS125-15 ⁴ (25EQ)	0.0155	0.0147	50	0.35	0.102	0.199	1.390	0.0190	0.435	0.205	0.058	1.60	3.48	2.90	2.47 (18MIL)	24.5
		400VS125-15 ⁴ (25EQ)	0.0155	0.0147	50	0.37	0.108	0.250	1.520	0.0200	0.429	0.255	0.061	1.69	3.99	3.06	2.74 (18MIL)	24.4
		600VS125-15 ⁵ (25EQ)	0.0155	0.0147	50	0.47	0.139	0.659	2.180	0.0220	0.397	0.628	0.085	2.36	5.90	4.27	4.13 (18MIL)	23.7
VIPER20	20EQ (18)	162VS125-18-70 (20EQ)	0.0190	0.0181	70	0.285	0.084	0.039	0.683	0.0179	0.462	0.0328	0.0285	1.19	1.99	2.02	1.99 (30MIL)	21.2
		250VS125-18-70 (20EQ)	0.0190	0.0181	70	0.351	0.103	0.106	1.010	0.0227	0.469	0.0942	0.0581	2.09	4.07	3.49	3.49 (30MIL)	21.9
		362VS125-18-70 (20EQ)	0.0190	0.0181	70	0.423	0.124	0.249	1.420	0.0256	0.454	0.213	0.0755	3.08	5.28	5.14	5.14 (30MIL)	21.5
		400VS125-18-70 (20EQ)	0.0190	0.0181	70	0.449	0.132	0.315	1.550	0.0266	0.449	0.265	0.085	3.44	5.93	5.74	5.74 (30MIL)	21.5
		600VS125-18-70 ⁶ (20EQ)	0.0190	0.0181	70	0.586	0.172	0.846	2.220	0.0319	0.430	0.647	0.151	5.41	10.60	9.04	9.00 (30MIL)	21.5
VIPER 30MIL	20 (30)	162VS125-30	0.0312	0.0296	33	0.46	0.135	0.062	0.688	0.0280	0.455	0.062	0.067	1.32	2.21	2.38	1.99 (30MIL)	30.8
		250VS125-30	0.0312	0.0296	33	0.55	0.161	0.166	1.020	0.0320	0.045	0.163	0.120	2.31	3.96	3.86	3.49 (30MIL)	30.1
		362VS125-30	0.0312	0.0296	33	0.67	0.197	0.391	1.410	0.0370	0.431	0.385	0.172	3.39	5.67	5.85	5.14 (30MIL)	29.7
		400VS125-30	0.0312	0.0296	33	0.71	0.209	0.493	1.540	0.0380	0.425	0.486	0.191	3.78	6.31	6.52	5.74 (30MIL)	29.6
		600VS125-30	0.0312	0.0296	33	0.92	0.271	1.310	2.190	0.0420	0.392	1.230	0.341	5.95	11.30	9.93	9.00 (30MIL)	28.7
VIPER 33MIL	20 (33)	162VS125-33	0.0346	0.0329	33	0.50	0.147	0.069	0.683	0.0300	0.453	0.068	0.077	1.53	2.55	2.71	2.29 (33MIL)	30.8
		250VS125-33	0.0346	0.0329	33	0.61	0.178	0.183	1.010	0.0360	0.447	0.181	0.137	2.65	4.53	4.42	4.02 (33MIL)	30.1
		362VS125-33	0.0346	0.0329	33	0.75	0.220	0.432	1.400	0.0400	0.429	0.428	0.201	3.96	6.62	6.75	6.00 (33MIL)	29.7
		400VS125-33	0.0346	0.0329	33	0.78	0.230	0.544	1.540	0.0410	0.424	0.539	0.224	4.42	7.38	7.53	6.70 (33MIL)	29.5
		600VS125-33	0.0346	0.0329	33	1.02	0.301	1.440	2.190	0.0460	0.391	1.390	0.400	6.93	13.20	11.60	10.55 (33MIL)	28.6

Notes:

- Nominal Moments for Viper25 are based on testing. Allowable moment (Ma) is calculated with safety factor of 1.81 in accordance with chapter F of AISI S100-16/S2-20 specification.
- Nominal moment for Viper20, Viper 30mil, Viper 33mil and conventional studs are based on calculations per AISI S100-16/S2-20.
- Section properties are in accordance with AISI S100-16/S2-20.
- Web depth-to-thickness ratio exceeds 200.
- Web depth-to-thickness ratio exceeds 260.
- ViperStud is considered fully braced when the unbraced length is less than listed Lu.
- K_D assumed to be zero for distortional buckling moments.

VIPERTRACK®

PRODUCT NAME	LEG SIZE (in)	WEIGHT (lb/ft)	DESIGN (in)	MIN. (in)	YIELD (ksi)	GROSS PROPERTIES						EFFECTIVE PROPERTIES			TORSIONAL PROPERTIES						
						AREA (in²)	I _x (in⁴)	S _x (in³)	R _x (in)	I _y (in⁴)	S _y (in³)	R _y (in)	I _{xd} (in⁴)	S _{xe} (in³)	Ma (in-k)	X _o (in)	J _x 10 ³ (in⁴)	C _w (in⁶)	R _o (in)	β	
VIPERTRACK 1.25" LEG																					
162VT125-15 (25EQ)	1.25	0.22	0.0155	0.0147	50	0.064	0.035	0.040	0.736	0.011	0.013	0.412	0.022	0.018	0.53	-0.877	0.0051	0.006	1.22	0.480	
250VT125-15 (25EQ)	1.25	0.26	0.0155	0.0147	50	0.078	0.086	0.066	1.050	0.012	0.013	0.400	0.054	0.027	0.80	-0.768	0.0062	0.015	1.36	0.683	
362VT125-15 (25EQ)	1.25	0.32	0.0155	0.0147	50	0.095	0.197	0.105	1.440	0.014	0.014	0.381	0.115	0.039	1.15	-0.665	0.0076	0.035	1.63	0.833	
400VT125-15 (25EQ)	1.25	0.34	0.0155	0.0147	50	0.101	0.247	0.120	1.560	0.014	0.014	0.374	0.141	0.043	1.27	-0.638	0.0081	0.043	1.73	0.864	
600VT125-15 (25EQ)	1.25	0.45	0.0155	0.0147	50	0.132	0.642	0.210	2.210	0.015	0.015	0.342	0.325	0.063	1.90	-0.523	0.0106	0.109	2.29	0.948	
162VT125-18-50 (20EQ)	1.25	0.26	0.0190	0.0181	50	0.077	0.033	0.042	0.660	0.013	0.015	0.407	0.0190	0.0180	0.44	-0.878	0.0092	0.0060	1.170	0.438	
250VT125-18-50 (20EQ)	1.25	0.32	0.0190	0.0181	50	0.093	0.091	0.073	0.986	0.014	0.016	0.392	0.0550	0.0350	0.88	-0.747	0.0011	0.0160	1.300	0.668	
362VT125-18-50 (20EQ)	1.25	0.39	0.0190	0.0181	50	0.115	0.218	0.121	1.377	0.016	0.016	0.370	0.1320	0.0570	1.43	-0.636	0.0138	0.0380	1.560	0.834	
400VT125-18-50 (20EQ)	1.25	0.41	0.0190	0.0181	50	0.122	0.275	0.139	1.503	0.016	0.016	0.363	0.1660	0.0650	1.62	-0.606	0.0146	0.0480	1.660	7.000	
600VT125-18-50 (20EQ)	1.25	0.54	0.0190	0.0181	50	0.160	0.740	0.248	2.152	0.017	0.011	0.330	0.4200	0.1050	2.63	-0.490	0.0192	0.1220	2.230	0.952	
162VT125-30	1.25	0.44	0.0312	0.0296	33	0.129	0.071	0.080	0.741	0.022	0.025	0.409	0.056	0.051	1.00	-0.868	0.0419	0.012	1.21	0.488	
250VT125-30	1.25	0.53	0.0312	0.0296	33	0.156	0.175	0.132	1.060	0.025	0.027	0.397	0.142	0.090	1.77	-0.760	0.0508	0.030	1.36	0.689	
362VT125-30	1.25	0.65	0.0312	0.0296	33	0.192	0.399	0.211	1.440	0.027	0.028	0.378	0.331	0.152	3.00	-0.658	0.0621	0.069	1.63	0.837	
400VT125-30	1.25	0.69	0.0312	0.0296	33	0.203	0.499	0.240	1.570	0.028	0.028	0.371	0.417	0.176	3.47	-0.631	0.0659	0.086	1.73	0.867	
600VT125-30	1.25	0.90	0.0312	0.0296	33	0.266	1.300	0.421	2.210	0.031	0.029	0.339	1.030	0.250	4.94	-0.517	0.0862	0.216	2.29	0.949	
162VT125-33	1.25	0.49	0.0346	0.0329	33	0.143	0.079	0.088	0.742	0.024	0.028	0.408	0.064	0.059	1.16	-0.866	0.0571	0.013	1.21	0.489	
250VT125-33	1.25	0.59	0.0346	0.0329	33	0.174	0.195	0.146	1.060	0.027	0.029	0.396	0.162	0.103	2.04	-0.758	0.0692	0.033	1.36	0.690	
362VT125-33	1.25	0.72	0.0346	0.0329	33	0.212	0.443	0.234	1.440	0.030	0.031	0.377	0.375	0.173	3.43	-0.657	0.0848	0.077	1.63	0.838	
400VT125-33	1.25	0.77	0.0346	0.0329	33	0.225	0.554	0.266	1.570	0.031	0.031	0.370	0.473	0.200	3.95	-0.629	0.0899	0.096	1.73	0.868	
600VT125-33	1.25	1.00	0.0346	0.0329	33	0.295	1.440	0.467	2.210	0.034	0.032	0.339	1.190	0.298	5.89	-0.516	0.1180	0.239	2.29	0.949	

Notes:

- Section properties are in accordance with AISI S100-16/S2-20.
- Cold-work of forming is not included.
- The effective moment of inertia for deflection is calculated based on AISI S100-16/S2-20 procedure 1 for serviceability determination.
- The center line bend radius is greater than 2 times the design thickness or 3/32".
- Web-to-thickness ratio exceeds 200.
- Web-to-thickness ratio exceeds 260.
- Flange-width-to-thickness-ratio exceeds 60, only gross properties will be determined.



DEEP LEG VIPERTRACK SECTION PROPERTIES



VIPERTRACK®

PRODUCT NAME	LEG SIZE (in)	WEIGHT (lb/ft)	DESIGN (in)	MIN. (in)	YIELD (ksi)	GROSS PROPERTIES						EFFECTIVE PROPERTIES			TORSIONAL PROPERTIES						
						AREA (in ²)	I _x (in ⁴)	S _x (in ³)	R _x (in)	I _y (in ⁴)	S _y (in ³)	R _y (in)	I _{xd} (in ⁴)	S _{xe} (in ³)	Ma (in-k)	X _o (in)	J _x 10 ³ (in ⁶)	C _w (in ⁶)	R _o (in)	β	
VIPERTRACK 1.50" LEG																					
162VT150-15' (25EQ)	1.50	0.2424	0.0155	0.0147	50	0.0713	0.0364	0.0439	0.7141	0.0173	0.0349	0.4930	0.0167	0.0142	0.3542	-1.101	0.0057	0.0083	1.402	0.355	
250VT150-15' (25EQ)	1.50	0.2885	0.0155	0.0147	50	0.0849	0.0928	0.0733	1.0455	0.0197	0.0466	0.4819	0.0459	0.0262	0.6552	-0.965	0.0068	0.0223	1.502	0.586	
362VT150-15' (25EQ)	1.50	0.3478	0.0155	0.0147	50	0.1023	0.2138	0.1169	1.4450	0.0219	0.0611	0.4621	0.1059	0.0414	1.0358	-0.840	0.0082	0.0525	1.734	0.902	
400VT150-15' (25EQ)	1.50	0.3676	0.0155	0.0147	50	0.1081	0.2679	0.1329	1.5742	0.0224	0.0658	0.4552	0.1318	0.0466	1.1644	-0.806	0.0087	0.0658	1.826	1.010	
600VT150-15' (25EQ)	1.50	0.4730	0.0155	0.0147	50	0.1391	0.6952	0.2305	2.2354	0.2460	0.0900	0.4205	0.3220	0.1904	1.8545	-0.667	0.0111	0.1677	2.370	1.607	
162VT150-18'-50 (20EQ)	1.50	0.2975	0.0190	0.0181	50	0.0875	0.0448	0.0539	0.7156	0.0213	0.0428	0.4936	0.0225	0.0195	0.4870	-1.102	0.0011	0.0103	1.404	0.437	
250VT150-18'-50 (20EQ)	1.50	0.3540	0.0190	0.0181	50	0.1041	0.1141	0.0899	1.0469	0.0243	0.0570	0.4825	0.0623	0.0370	0.9239	-0.966	0.0125	0.0275	1.504	0.721	
362VT150-18'-50 (20EQ)	1.50	0.4267	0.0190	0.0181	50	0.1255	0.2627	0.1434	1.4468	0.0269	0.0746	0.4627	0.1446	0.0589	1.4728	-0.841	0.0151	0.0646	1.736	1.109	
400VT150-18'-50 (20EQ)	1.50	0.4509	0.0190	0.0181	50	0.1326	0.3292	0.1631	1.5755	0.0273	0.0804	0.4558	0.1804	0.0663	1.6582	-0.807	0.0160	0.0811	1.828	1.242	
600VT150-18'-50 (20EQ)	1.50	0.5801	0.0190	0.0181	50	0.1706	0.8537	0.2828	2.2368	0.3003	0.1098	0.4211	0.4437	0.1061	2.6535	-0.668	0.2053	0.2065	2.372	1.976	
162VT150-30	1.50	0.4906	0.0312	0.0296	33	0.1443	0.0749	0.0888	0.7205	0.0355	0.0700	0.4957	0.0507	0.0484	0.7990	-1.107	0.0468	0.0173	1.411	0.481	
250VT150-30	1.50	0.5834	0.0312	0.0296	33	0.1716	0.1898	0.1481	1.0517	0.0403	0.0930	0.4847	0.1350	0.0880	1.4524	-0.971	0.0557	0.0460	1.551	0.791	
362VT150-30	1.50	0.7027	0.0312	0.0296	33	0.2067	0.4354	0.2392	1.4515	0.0446	0.1214	0.4648	0.3245	0.1518	2.5047	-0.846	0.0671	0.1046	1.743	1.215	
400VT150-30	1.50	0.7425	0.0312	0.0296	33	0.2184	0.5453	0.2685	1.5802	0.0458	0.1304	0.4580	0.4095	0.2387	2.8797	-0.812	0.0709	0.1354	1.835	1.360	
600VT150-30	1.50	0.9547	0.0312	0.0296	33	0.2808	1.4106	0.4654	2.2141	0.0503	0.1776	0.4232	1.0401	0.4209	4.7787	-0.672	0.0911	0.3442	2.378	2.162	
162VT150-33	1.50	0.5446	0.0346	0.0329	33	0.1602	0.0835	0.0986	0.7219	0.0395	0.0775	0.4963	0.0586	0.0567	0.9351	-1.109	0.0639	0.0193	1.413	0.535	
250VT150-33	1.50	0.6476	0.0346	0.0329	33	0.1905	0.2112	0.1644	1.0530	0.0485	0.1029	0.4853	0.1551	0.1022	2.0199	-0.973	0.0760	0.0513	1.513	0.880	
362VT150-33	1.50	0.7799	0.0346	0.0329	33	0.2294	0.4841	0.2621	1.4528	0.0497	0.1343	0.4654	0.3806	0.2351	3.4576	-0.847	0.0915	0.1203	1.745	1.351	
400VT150-33	1.50	0.8240	0.0346	0.0329	33	0.2424	0.6062	0.2979	1.5815	0.0510	0.1444	0.4586	0.4692	0.2027	4.0050	-0.813	0.0967	0.1509	1.836	1.513	
600VT150-33	1.50	1.0593	0.0346	0.0329	33	0.3116	1.5670	0.5164	2.2427	0.0559	0.1961	0.4238	1.2029	0.4708	6.7643	-0.673	0.1243	0.3832	2.380	2.404	
VIPERTRACK 2.00" LEG																					
162VT200-15 (25EQ)	2.00	0.30	0.0155	0.0147	50	0.087	0.052	0.060	0.773	0.038	0.030	0.663	0.025	0.017	0.50	-1.57	0.0070	0.0212	1.87	0.295	
250VT200-15 (25EQ)	2.00	0.34	0.0155	0.0147	50	0.101	0.126	0.096	1.117	0.044	0.032	0.662	0.060	0.026	0.79	-1.43	0.0081	0.0535	1.93	0.453	
362VT200-15 (25EQ)	2.00	0.40	0.0155	0.0147	50	0.118	0.278	0.148	1.533	0.050	0.034	0.648	0.127	0.039	1.16	-1.28	0.0095	0.1220	2.10	0.629	
400VT200-15 (25EQ)	2.00	0.42	0.0155	0.0147	50	0.124	0.345	0.167	1.667	0.051	0.034	0.642	0.155	0.043	1.28	-1.24	0.0100	0.1520	2.17	0.676	
600VT200-15 (25EQ)	2.00	0.53	0.0155	0.0147	50	0.155	0.859	0.281	2.353	0.057	0.036	0.608	0.357	0.065	1.93	-1.06	0.0124	0.3840	2.65	0.841	
162VT200-18-70 (20EQ)	2.00	0.36	0.0190	0.0181	70	0.105	0.049	0.061	0.681	0.045	0.036	0.656	0.020	0.017	0.59	-1.591	0.0013	0.022	1.85	0.261	
250VT200-18-70 (20EQ)	2.00	0.41	0.0190	0.0181	70	0.122	0.130	0.105	1.032	0.052	0.038	0.653	0.058	0.033	1.15	-1.415	0.0147	0.059	1.87	0.427	
362VT200-18-70 (20EQ)	2.00	0.49	0.0190	0.0181	70	0.143	0.303	0.169	1.455	0.058	0.040	0.637	0.136	0.053	1.84	-1.253	0.0172	0.137	2.02	0.616	
400VT200-18-70 (20EQ)	2.00	0.51	0.0190	0.0181	70	0.150	0.380	0.192	1.591	0.060	0.041	0.631	0.170	0.059	2.07	-1.209	0.0181	0.172	2.10	0.667	
600VT200-18-70 (20EQ)	2.00	0.64	0.0190	0.0181	70	0.188	0.983	0.329	2.285	0.067	0.042	0.595	0.421	0.095	3.34	-1.023	0.0227	0.439	2.57	0.842	
162VT200-30	2.00	0.60	0.0312	0.0296	33	0.176	0.107	0.120	0.779	0.077	0.060	0.660	0.069	0.055	1.09	-1.56	0.057	0.043	1.87	0.299	
250VT200-30	2.00	0.69	0.0312	0.0296	33	0.203	0.256	0.193	1.120	0.088	0.064	0.659	0.174	0.098	1.94	-1.42	0.066	0.108	1.92	0.457	
362VT200-30	2.00	0.81	0.0312	0.0296	33	0.238	0.563	0.298	1.540	0.099	0.068	0.645	0.400	0.167	3.29	-1.27	0.077	0.246	2.10	0.633	
400VT200-30	2.00	0.85	0.0312	0.0296	33	0.250	0.698	0.336	1.670	0.102	0.068	0.639	0.502	0.188	3.71	-1.23	0.081	0.306	2.17	0.680	
600VT200-30	2.00	1.06	0.0312	0.0296	33	0.312	1.735	0.564	2.360	0.114	0.072	0.605	1.270	0.276	5.45	-1.05	0.101	0.769	2.65	0.843	
162VT200-33	2.00	0.66	0.0346	0.0329	33	0.195	0.119	0.133	0.780	0.085	0.066	0.660	0.080	0.064	1.27	-1.56	0.078	0.048	1.87	0.300	
250VT200-33	2.00	0.77	0.0346	0.0329	33	0.225	0.284	0.214	1.120	0.098	0.071	0.658	0.199	0.113	2.23	-1.42	0.090	0.120	1.92	0.458	
362VT200-33	2.00	0.90	0.0346	0.0329	33	0.264	0.626	0.330	1.540	0.110	0.075	0.644	0.455	0.191	3.76	-1.27	0.105	0.272	2.10	0.634	
400VT200-33	2.00	0.94	0.0346	0.0329	33	0.277	0.775	0.373	1.670	0.113	0.076	0.638	0.570	0.220	4.34	-1.23	0.111	0.340	2.17	0.680	
600VT200-33	2.00	1.18	0.0346	0.0329	33	0.347	1.930	0.625	2.360	0.126	0.080	0.604	1.480	0.338	6.69	-1.05	0.138	0.852	2.65	0.844	

Notes:

1. Section properties are in accordance with AISI S100-16/S2-20.
2. Cold-work of forming is not included.
3. The effective moment of inertia for deflection is calculated based on AISI S100-16/S2-20 procedure 1 for serviceability determination.
4. The center line bend radius is greater than 2 times the design thickness or 3/32".
5. Web-to-thickness ratio exceeds 200.
6. Web-to-thickness ratio exceeds 260.
7. Flange-width-to-thickness-ratio exceeds 60, only gross properties will be determined.



DEEP LEG VIPERTRACK SECTION PROPERTIES (CONTINUED)



VIPERTRACK®

PRODUCT NAME	LEG SIZE (in)	WEIGHT (lb/ft)	DESIGN (in)	MIN. (in)	YIELD (ksi)	GROSS PROPERTIES							EFFECTIVE PROPERTIES			TORSIONAL PROPERTIES					
						AREA (in ²)	I _x (in ⁴)	S _x (in ³)	R _x (in)	I _y (in ⁴)	S _y (in ³)	R _y (in)	I _{xd} (in ⁴)	S _{xe} (in ³)	Ma (in-k)	X _o (in)	J _x 10 ³ (in ⁶)	C _w (in ⁴)	R _o (in)	β	
VIPERTRACK 2.50" LEG																					
250VT250-18-70 (20EQ)	2.50	0.54	0.0190	0.0181	70	0.160	0.179	0.145	1.059	0.155	0.081	0.986	0.063	0.033	1.17	-2.634	0.0192	0.1840	2.77	0.273	
362VT250-18-70 (20EQ)	2.50	0.62	0.0190	0.0181	70	0.162	0.359	0.200	1.487	0.107	0.061	0.812	0.143	0.053	1.85	-1.695	0.0195	0.2540	2.40	0.500	
400VT250-18-70 (20EQ)	2.50	0.64	0.0190	0.0181	70	0.169	0.488	0.226	1.628	0.110	0.062	0.807	0.178	0.060	2.09	-1.642	0.0204	0.3170	2.45	0.551	
600VT250-18-70 (20EQ)	2.50	0.77	0.0190	0.0181	70	0.207	1.143	0.383	2.348	0.124	0.065	0.774	0.438	0.096	3.36	-1.416	0.0249	0.8060	2.85	0.753	
162VT250-30	2.50	0.71	0.0312	0.0296	33	0.207	0.131	0.147	0.794	0.140	0.090	0.822	0.076	0.057	1.13	-2.04	0.0672	0.0800	2.34	0.239	
250VT250-30	2.50	0.80	0.0312	0.0296	33	0.234	0.310	0.233	1.150	0.161	0.097	0.828	0.190	0.102	2.01	-1.88	0.0761	0.1990	2.35	0.363	
362VT250-30	2.50	0.92	0.0312	0.0296	33	0.270	0.673	0.356	1.580	0.181	0.102	0.820	0.437	0.167	3.30	-1.71	0.0875	0.4490	2.47	0.521	
400VT250-30	2.50	0.96	0.0312	0.0296	33	0.281	0.831	0.400	1.720	0.187	0.104	0.816	0.548	0.185	3.66	-1.66	0.0913	0.5600	2.52	0.568	
600VT250-30	2.50	1.17	0.0312	0.0296	33	0.344	2.030	0.659	2.430	0.211	0.110	0.784	1.330	0.275	5.43	-1.44	0.1120	1.4000	2.93	0.758	
162VT250-33	2.50	0.78	0.0346	0.0329	33	0.230	0.145	0.163	0.796	0.155	0.100	0.821	0.088	0.066	1.31	-2.04	0.0917	0.0890	2.34	0.239	
250VT250-33	2.50	0.89	0.0346	0.0329	33	0.260	0.344	0.258	1.150	0.178	0.107	0.827	0.218	0.117	2.32	-1.88	0.1040	0.2210	2.35	0.363	
362VT250-33	2.50	1.02	0.0346	0.0329	33	0.299	0.748	0.395	1.580	0.201	0.114	0.820	0.498	0.198	3.92	-1.71	0.1190	0.4980	2.47	0.522	
400VT250-33	2.50	1.06	0.0346	0.0329	33	0.312	0.923	0.443	1.720	0.207	0.115	0.815	0.623	0.226	4.46	-1.66	0.1240	0.6210	2.52	0.569	
600VT250-33	2.50	1.30	0.0346	0.0329	33	0.381	2.250	0.730	2.430	0.234	0.122	0.783	1.580	0.336	6.64	-1.44	0.1520	1.5500	2.93	0.759	
VIPERTRACK 3.00" LEG																					
250VT300-18-70 (20EQ)	3.00	0.59	0.0190	0.0181	70	0.175	0.237	0.180	1.170	0.173	0.089	0.995	0.098	0.041	1.39	-2.36	0.0245	0.2160	2.81	0.298	
362VT300-18-70 (20EQ)	3.00	0.67	0.0190	0.0181	70	0.181	0.413	0.230	1.510	0.175	0.086	0.984	0.163	0.060	1.50	-2.152	0.0218	0.4210	2.81	0.412	
400VT300-18-70 (20EQ)	3.00	0.75	0.0190	0.0181	70	0.188	0.516	0.260	1.656	0.181	0.087	0.981	0.184	0.060	2.10	-2.092	0.0227	0.5260	2.84	0.458	
600VT300-18-70 (20EQ)	3.00	0.90	0.0190	0.0181	70	0.226	1.301	0.436	2.397	0.205	0.092	0.952	0.451	0.096	3.38	-1.831	0.0272	1.3250	3.16	0.665	
162VT300-30	3.00	0.81	0.0312	0.0296	33	0.238	0.155	0.174	0.805	0.229	0.126	0.980	0.081	0.058	1.15	-2.53	0.0773	0.1340	2.83	0.201	
250VT300-30	3.00	0.90	0.0312	0.0296	33	0.266	0.363	0.274	1.170	0.262	0.135	0.993	0.204	0.104	2.06	-2.35	0.0862	0.3290	2.80	0.299	
362VT300-30	3.00	1.02	0.0312	0.0296	33	0.301	0.783	0.414	1.610	0.296	0.144	0.992	0.469	0.165	3.25	-2.16	0.0976	0.7380	2.87	0.435	
400VT300-30	3.00	1.06	0.0312	0.0296	33	0.312	0.964	0.464	1.760	0.306	0.146	0.989	0.587	0.183	3.61	-2.10	0.1010	0.9180	2.91	0.479	
600VT300-30	3.00	1.28	0.0312	0.0296	33	0.375	2.320	0.754	2.490	0.347	0.155	0.962	1.380	0.274	5.41	-1.85	0.1220	2.2900	3.25	0.674	
162VT300-33	3.00	0.90	0.0346	0.0329	33	0.264	0.172	0.192	0.807	0.254	0.139	0.979	0.094	0.068	1.34	-2.52	0.1050	0.1490	2.82	0.202	
250VT300-33	3.00	1.00	0.0346	0.0329	33	0.295	0.404	0.303	1.170	0.290	0.150	0.993	0.234	0.120	2.38	-2.35	0.1180	0.3660	2.80	0.300	
362VT300-33	3.00	1.14	0.0346	0.0329	33	0.334	0.869	0.459	1.620	0.328	0.159	0.992	0.535	0.200	3.96	-2.16	0.1330	0.8190	2.87	0.436	
400VT300-33	3.00	1.18	0.0346	0.0329	33	0.347	1.070	0.514	1.760	0.339	0.162	0.988	0.669	0.223	4.40	-2.10	0.1380	1.0200	2.91	0.480	
600VT300-33	3.00	1.41	0.0346	0.0329	33	0.416	2.580	0.836	2.490	0.384	0.171	0.961	1.640	0.334	6.60	-1.85	0.1660	2.5400	3.25	0.675	

Notes:

1. Section properties are in accordance with AISI S100-16/S2-20.
2. Cold-work of forming is not included.
3. The effective moment of inertia for deflection is calculated based on AISI S100-16/S2-20 procedure 1 for serviceability determination.
4. The center line bend radius is greater than 2 times the design thickness or 3/32".
5. Web-to-thickness ratio exceeds 200.
6. Web-to-thickness ratio exceeds 260.
7. Flange-width-to-thickness-ratio exceeds 60, only gross properties will be determined.



SELECT MARKETS ONLY (18 mil, 33 ksi)



VIPERSTUD® SECTION PROPERTIES

MODEL NO.	GAUGE (mils)	MEMBER	DESIGN (in)	MIN. (in)	YIELD (ksi)	WEIGHT (lb/ft)	GROSS PROPERTIES					EFFECTIVE PROPERTIES		MOMENTS				CRITICAL UNBRACED LENGTH (in)
							AREA (in²)	I _x (in⁴)	R _x (in)	I _y (in⁴)	R _y (in)	I _{xd} (in⁴)	S _x (in²)	Ma (in-k)	Local Buckling Nominal Moment² Viper (in-k)	Distortional Buckling Nominal Moment² Viper (in-k)	Nominal Moment for Conventional Studs³ (in-k)	
VIPER 18mil	25 (18)	162VS125-18 (25 ga.)	0.0188	0.0179	33	0.28	0.069	0.039	0.684	0.018	0.461	0.037	0.035	0.68	1.14	1.23	1.02 (18MIL)	30.70
		250VS125-18 (25 ga.)	0.0188	0.0179	33	0.34	0.099	0.102	1.015	0.020	0.454	0.098	0.065	1.29	2.15	1.95	1.72 (18MIL)	29.70
		362VS125-18 (25 ga.)	0.0188	0.0179	33	0.41	0.120	0.241	1.414	0.023	0.437	0.237	0.084	1.65	2.76	2.89	2.47 (18MIL)	29.90
		400VS125-18 (25 ga.)	0.0188	0.0179	33	0.43	0.127	0.303	1.542	0.024	0.431	0.299	0.093	1.83	3.06	3.20	2.74 (18MIL)	29.80

- Notes:**
- Section properties are in accordance with AISI S100-16/S2-20. Viper 25 and Viper20 section properties are based on testing. Allowable moment (Ma) is calculated with a safety factor of 1.81 in accordance with Chapter F of AISI S100-16/S2-20 specification.
 - Nominal moment for Viper 18 mil, Viper 30 mil, and Viper 33 mil conventional studs are based on calculations in accordance with AISI S100-16/S2-20. Allowable moments (Ma) can be calculated with a 1.67 safety factor.
 - Section properties are in accordance with AISI S100-16/S2-20.
 - Web depth-to-thickness ratio exceeds 200.
 - Web depth-to-thickness ratio exceeds 260.
 - ViperStud is considered fully braced when unbraced length is less than listed Lu.
 - K Φ assumed to be zero for distortional buckling moments.

VIPERTRACK® SECTION PROPERTIES

PRODUCT NAME	LEG SIZE (in)	WEIGHT (lb/ft)	DESIGN (in)	MIN. (in)	YIELD (ksi)	GROSS PROPERTIES						EFFECTIVE PROPERTIES			TORSIONAL PROPERTIES					
						AREA (in²)	I _x (in⁴)	S _x (in²)	R _x (in)	I _y (in⁴)	S _y (in²)	R _y (in)	I _{xd} (in⁴)	S _{xe} (in²)	Ma (in-k)	X _o (in)	J _x 10³ (in⁴)	C _w (in⁶)	R _o (in)	β
VIPERTRACK 1.25" LEG																				
162VT125-18 (25 ga.)	1.25	0.26	0.0188	0.0179	33	0.077	0.042	0.048	0.733	0.013	0.0149	0.411	0.030	0.025	0.50	-0.878	0.009	0.007	1.215	0.478
250VT125-18 (25 ga.)	1.25	0.32	0.0188	0.0179	33	0.094	0.105	0.080	1.057	0.015	0.0160	0.399	0.079	0.046	0.90	-0.766	0.011	0.018	1.366	0.685
362VT125-18 (25 ga.)	1.25	0.39	0.0188	0.0179	33	0.115	0.240	0.127	1.442	0.017	0.0168	0.380	0.192	0.066	1.30	-0.664	0.014	0.042	1.632	0.835
400VT125-18 (25 ga.)	1.25	0.42	0.0188	0.0179	33	0.122	0.300	0.145	1.566	0.017	0.0170	0.374	0.244	0.072	1.43	-0.636	0.014	0.053	1.731	0.865
600VT125-18 ^{6,7} (25 ga.)	1.25	0.54	0.0188	0.0179	33	0.160	0.779	0.254	2.208	0.019	0.0176	0.342	-	-	-	-0.521	0.019	0.132	2.294	0.948
VIPERTRACK 2.00" LEG																				
250VT200-18 ⁶ (25 ga.)	2.00	0.42	0.0188	0.0179	33	0.122	0.154	0.116	1.121	0.053	0.0383	0.661	-	-	-	-1.43	0.014	0.066	1.93	0.455
362VT200-18 ⁶ (25 ga.)	2.00	0.49	0.0188	0.0179	33	0.144	0.339	0.180	1.537	0.060	0.0407	0.647	-	-	-	-1.28	0.017	0.149	2.10	0.630
400VT200-18 ⁶ (25 ga.)	2.00	0.51	0.0188	0.0179	33	0.151	0.420	0.203	1.670	0.062	0.0412	0.642	-	-	-	-1.24	0.018	0.186	2.17	0.677
600VT200-18 ^{6,7} (25 ga.)	2.00	0.64	0.0188	0.0179	33	0.188	1.039	0.339	2.350	0.069	0.0434	0.607	-	-	-	-1.06	0.022	0.464	2.65	0.841

- Notes:**
- Section properties are in accordance with AISI S100-16/S2-20.
 - Cold-work of forming is not included.
 - The effective moment of inertia for deflection is calculated based on AISI S100-16/S2-20 procedure 1 for serviceability determination.
 - The center line bend radius is greater than 2 times the design thickness or 3/32".
 - Web-to-thickness ratio exceeds 200.
 - Web-to-thickness ratio exceeds 260.
 - Flange-width-to-thickness-ratio exceeds 60.



COMPOSITE LIMITING HEIGHTS – 5/8" TYPE X



MODEL NO.	DEPTH	GAUGE (mil.)	MEMBER	DESIGN (in)	MIN. (in)	YIELD (ksi)	SPACING O.C. (in)	5 PSF			7.5 PSF			10 PSF		
								L/120	L/240	L/360	L/120	L/240	L/360	L/120	L/240	L/360
VIPER25	1-5/8"	25EQ (15)	162VS125-15 (25EQ)	0.0155	0.0147	50	12	13'-9"	11'-4"	9'-10"	12'-0"	9'-11"	8'-3"	10'-11"	8'-10"	--
			162VS125-15 (25EQ)	0.0155	0.0147	50	16	12'-6"	10'-4"	8'-8"	10'-11"	8'-10"	--	9'-11"	7'-11"	--
			162VS125-15 (25EQ)	0.0155	0.0147	50	24	10'-11"	8'-10"	--	9'-5"	--	--	8'-2"	--	--
	2-1/2"	25EQ (15)	250VS125-15 (25EQ)	0.0155	0.0147	50	12	17'-3"	14'-5"	12'-9"	15'-0"	12'-7"	11'-1"	13'-8"	11'-6"	10'-1"
			250VS125-15 (25EQ)	0.0155	0.0147	50	16	15'-8"	13'-1"	11'-7"	13'-8"	11'-6"	10'-1"	12'-3"	10'-5"	8'-9"
			250VS125-15 (25EQ)	0.0155	0.0147	50	24	13'-8"	11'-6"	10'-1"	11'-6"	10'-0"	8'-2"	10'-0"	8'-8"	--
	3-5/8"	25EQ (15)	362VS125-15 (25EQ)	0.0155	0.0147	50	12	20'-10"	17'-3"	15'-2"	18'-2"	15'-1"	13'-3"	15'-10"	13'-9"	12'-0"
			362VS125-15 (25EQ)	0.0155	0.0147	50	16	18'-11"	15'-9"	13'-9"	15'-10"	13'-9"	12'-0"	13'-9"	12'-6"	10'-11"
			362VS125-15 (25EQ)	0.0155	0.0147	50	24	15'-10"	13'-9"	12'-0"	12'-11"	12'-0"	10'-6"	11'-3"	10'-11"	9'-6"
	4"	25EQ (15)	400VS125-15 (25EQ)	0.0155	0.0147	50	12	22'-1"	18'-3"	16'-3"	19'-3"	15'-11"	14'-2"	16'-8"	14'-6"	12'-11"
			400VS125-15 (25EQ)	0.0155	0.0147	50	16	18'-11"	16'-7"	14'-9"	16'-8"	14'-6"	12'-11"	14'-5"	13'-2"	11'-9"
			400VS125-15 (25EQ)	0.0155	0.0147	50	24	16'-8"	14'-6"	12'-11"	13'-7"	12'-8"	11'-3"	11'-9"	11'-6"	10'-1"
	6"	25EQ (15)	600VS125-15 (25EQ)	0.0155	0.0147	50	12	24'-8"	23'-9"	21'-1"	22'-3"	20'-9"	18'-5"	20'-0"	18'-10"	16'-9"
			600VS125-15 (25EQ)	0.0155	0.0147	50	16	22'-11"	21'-7"	19'-2"	20'-0"	18'-10"	16'-9"	17'-5"	17'-2"	15'-3"
			600VS125-15 (25EQ)	0.0155	0.0147	50	24	20'-0"	18'-10"	16'-9"	16'-5"	16'-5"	14'-8"	13'-6"	13'-6"	13'-0"
VIPER20	1-5/8"	20EQ (18)	162VS125-18-70 (20EQ)	0.0190	0.0181	70	12	13'-10"	11'-0"	9'-7"	12'-1"	9'-7"	8'-5"	11'-0"	8'-9"	--
			162VS125-18-70 (20EQ)	0.0190	0.0181	70	16	12'-7"	10'-0"	8'-9"	11'-0"	8'-9"	7'-11"	10'-0"	7'-11"	--
			162VS125-18-70 (20EQ)	0.0190	0.0181	70	24	11'-0"	8'-9"	--	9'-7"	--	--	8'-9"	--	--
	2-1/2"	20EQ (18)	250VS125-18-70 (20EQ)	0.0190	0.0181	70	12	18'-2"	14'-5"	12'-7"	15'-10"	12'-7"	11'-0"	14'-5"	11'-5"	9'-10"
			250VS125-18-70 (20EQ)	0.0190	0.0181	70	16	16'-6"	13'-1"	11'-5"	14'-5"	11'-5"	9'-10"	13'-1"	10'-4"	8'-10"
			250VS125-18-70 (20EQ)	0.0190	0.0181	70	24	14'-5"	11'-5"	9'-10"	12'-7"	9'-10"	8'-5"	11'-5"	8'-10"	--
	3-5/8"	20EQ (18)	362VS125-18-70 (20EQ)	0.0190	0.0181	70	12	21'-11"	18'-0"	15'-10"	19'-1"	15'-9"	13'-10"	17'-5"	14'-3"	12'-7"
			362VS125-18-70 (20EQ)	0.0190	0.0181	70	16	19'-11"	16'-4"	14'-5"	17'-5"	14'-3"	12'-7"	15'-10"	13'-0"	11'-4"
			362VS125-18-70 (20EQ)	0.0190	0.0181	70	24	17'-5"	14'-3"	12'-7"	15'-2"	12'-6"	10'-10"	13'-6"	11'-3"	9'-9"
	4"	20EQ (18)	400VS125-18-70 (20EQ)	0.0190	0.0181	70	12	22'-11"	18'-11"	16'-8"	20'-0"	16'-7"	14'-7"	18'-2"	15'-1"	13'-3"
			400VS125-18-70 (20EQ)	0.0190	0.0181	70	16	20'-10"	17'-3"	15'-2"	18'-2"	15'-1"	13'-3"	16'-6"	13'-8"	12'-1"
			400VS125-18-70 (20EQ)	0.0190	0.0181	70	24	18'-2"	15'-1"	13'-3"	15'-10"	13'-2"	11'-7"	14'-5"	11'-11"	10'-5"
	6"	20EQ (18)	600VS125-18-70 (20EQ)	0.0190	0.0181	70	12	30'-6"	26'-0"	23'-0"	26'-7"	22'-9"	20'-1"	24'-2"	20'-8"	18'-4"
			600VS125-18-70 (20EQ)	0.0190	0.0181	70	16	27'-8"	23'-7"	20'-11"	24'-2"	20'-8"	18'-4"	22'-0"	18'-9"	16'-8"
			600VS125-18-70 (20EQ)	0.0190	0.0181	70	24	24'-2"	20'-8"	18'-4"	20'-11"	18'-0"	16'-0"	18'-1"	16'-5"	14'-7"
VIPER30MIL	1-5/8"	20 (30)	162VS125-30	0.0312	0.0296	33	12	14'-7"	11'-6"	10'-0"	12'-9"	10'-0"	8'-6"	11'-7"	8-11"	--
			162VS125-30	0.0312	0.0296	33	16	13'-3"	10'-5"	8'-11"	11'-7"	8'-11"	--	10'-6"	7'-10"	--
			162VS125-30	0.0312	0.0296	33	24	11'-7"	8-11"	--	10'-1"	--	--	8'-10"	--	--
	2-1/2"	20 (30)	250VS125-30	0.0312	0.0296	33	12	18'-9"	14'-10"	13'-0"	16'-4"	13'-0"	11'-4"	14'-10"	11'-10"	10'-4"
			250VS125-30	0.0312	0.0296	33	16	17'-0"	13'-6"	11'-10"	14'-10"	11'-10"	10'-4"	13'-6"	10'-9"	9'-3"
			250VS125-30	0.0312	0.0296	33	24	14'-10"	11'-10"	10'-4"	12'-9"	10'-4"	8'-10"	11'-0"	9'-3"	--
	3-5/8"	20 (30)	362VS125-30	0.0312	0.0296	33	12	23'-3"	18'-6"	16'-2"	20'-4"	16'-2"	14'-1"	18'-6"	14'-3"	12'-10"
			362VS125-30	0.0312	0.0296	33	16	21'-2"	16'-9"	14'-8"	18'-6"	14'-8"	12'-10"	16'-4"	13'-4"	11'-6"
			362VS125-30	0.0312	0.0296	33	24	18'-6"	14'-8"	12'-10"	15'-4"	12'-10"	11'-0"	13'-4"	11'-6"	9-11"
	4"	20 (30)	400VS125-30	0.0312	0.0296	33	12	25'-2"	20'-0"	17'-6"	22'-0"	17'-6"	15'-3"	19'-5"	15-11"	13'-10"
			400VS125-30	0.0312	0.0296	33	16	22'-11"	18'-2"	15'-11"	19'-5"	15'-11"	13'-10"	16'-10"	14'-5"	12'-7"
			400VS125-30	0.0312	0.0296	33	24	19'-5"	15'-11"	13'-10"	15'-10"	13'-10"	12'-1"	13'-6"	12'-7"	10-11"
	6"	20 (30)	600VS125-30	0.0312	0.0296	33	12	31'-10"	26'-9"	23'-4"	26'-0"	23'-4"	20'-5"	22'-6"	21'-3"	18'-6"
			600VS125-30	0.0312	0.0296	33	16	27'-7"	24'-3"	21'-3"	22'-6"	21'-3"	18'-6"	19'-6"	19'-3"	16'-10"
			600VS125-30	0.0312	0.0296	33	24	22'-6"	21'-3"	18'-6"	18'-0"	18'-0"	16'-2"	13'-6"	13'-6"	13'-6"
VIPER33MIL	1-5/8"	20 (33)	162VS125-33	0.0346	0.0329	33	12	14'-11"	11'-10"	10'-4"	13'-0"	10'-4"	8'-10"	11'-10"	9'-4"	--
			162VS125-33	0.0346	0.0329	33	16	13'-6"	10'-9"	9'-4"	11'-10"	9'-4"	--	10'-9"	8'-4"	--
			162VS125-33	0.0346	0.0329	33	24	11'-10"	9'-4"	--	10'-4"	--	--	9'-4"	--	--
	2-1/2"	20 (33)	250VS125-33	0.0346	0.0329	33	12	19'-4"	15'-4"	13'-5"	16'-10"	13'-5"	11'-8"	15'-4"	12'-2"	10'-8"
			250VS125-33	0.0346	0.0329	33	16	17'-7"	13'-11"	12'-2"	15'-4"	12'-2"	10'-8"	13'-11"	11'-0"	9-8"
			250VS125-33	0.0346	0.0329	33	24	15'-4"	12'-2"	10'-8"	13'-5"	10'-8"	9-2"	12'-0"	9-8"	--
	3-5/8"	20 (33)	362VS125-33	0.0346	0.0329	33	12	23'-10"	18'-11"	16'-6"	20'-10"	16'-6"	14'-5"	18'-11"	15'-0"	13'-1"
			362VS125-33	0.0346	0.0329	33	16	21'-8"	17'-2"	15'-0"	18'-11"	15'-0"	13'-1"	17'-2"	13'-8"	11'-10"
			362VS125-33	0.0346	0.0329	33	24	18'-11"	15'-0"	13'-1"	16'-6"	13'-1"	11'-4"	13'-6"	11'-10"	10'-3"
	4"	20 (33)	400VS125-33	0.0346	0.0329	33	12	25'-8"	20'-4"	17'-10"	22'-5"	17'-10"	15'-7"	20'-4"	16'-2"	14'-1"
			400VS125-33	0.0346	0.0329	33	16	23'-4"	18'-6"	16'-2"	20'-4"	16'-2"	14'-1"	18'-4"	14'-8"	12'-10"
			400VS125-33	0.0346	0.0329	33	24	20'-4"	16'-2"	14'-1"	17'-3"	14'-2"	12'-4"	13'-6"	12'-10"	11'-2"
	6"	20 (33)	600VS125-33	0.0346	0.0329	33	12	34'-5"	27'-7"	24'-1"	28'-1"	24'-1"	21'-1"	24'-4"	21'-11"	19'-2"
			600VS125-33	0.0346	0.0329	33	16	29'-10"	25'-1"	21'-11"	24'-4"	21'-11"	19'-2"	20'-3"	19-11"	17'-5"
			600VS125-33	0.0346	0.0329	33	24	24'-4"	21'-11"	19'-2"	18'-0"	18'-0"	16'-9"	13'-6"	13'-6"	13'-6"

Notes:

1. Sheathing, as specified in Section 3.2.2, must be attached to both faces of the wall for the full height of the wall with the long dimension parallel to the studs.
2. Sheathing must be fastened to the studs with fasteners as specified in Section 3.2.3 and installed per Section 4.2.1.
3. Placement of joints in the gypsum sheathing must be in accordance with Sections 4.6.3 and 4.6.4 of GA-216 or Section 7.5 of ASTM C840.
4. The bottom and top tracks are xxxVT125 (solid flange track). A minimum 30 mil slotted flange track (xxxCST250 or xxxSLT250) may be used for the top track.
5. End-bearing must be a minimum of 1 inch for xxxVT125 (solid flange track) and 1-5/8 inches for xxxCST250 or xxxSLT250 (slotted flange track).
6. Notes 1, 2, & 3 are referenced in ICC ESR 2620 page 5.
7. For any other top tracks not listed in note 4, please contact technical services for assistance.
8. For GWB installed horizontally, see table for "Non-Composite Limiting Heights- Fully Braced" (see above).



NON-COMPOSITE LIMITING HEIGHTS – FULLY BRACED



MODEL NO.	DEPTH	GAUGE (mil.)	MEMBER	DESIGN (in)	MIN. (in)	YIELD (ksi)	SPACING O.C. (in)	5 PSF			7.5 PSF			10 PSF		
								L/120	L/240	L/360	L/120	L/240	L/360	L/120	L/240	L/360
VIPER25	1-5/8"	25EQ (15)	162VS125-15 (25EQ)	0.0155	0.0147	50	12	9'-5"	7'-6"	6'-7"	7'-8"	6'-7"	--	6'-7"	6'-0"	--
			162VS125-15 (25EQ)	0.0155	0.0147	50	16	8'-1"	6'-10"	6'-0"	6'-7"	6'-0"	--	--	--	--
			162VS125-15 (25EQ)	0.0155	0.0147	50	24	6'-7"	6'-0"	--	--	--	--	--	--	--
	2-1/2"	25EQ (15)	250VS125-15 (25EQ)	0.0155	0.0147	50	12	12'-6"	10'-7"	9'-2"	10'-2"	9'-2"	8'-1"	8'-10"	8'-5"	7'-4"
			250VS125-15 (25EQ)	0.0155	0.0147	50	16	10'-10"	9'-7"	8'-5"	8'-10"	8'-5"	7'-4"	7'-8"	7'-7"	6'-8"
			250VS125-15 (25EQ)	0.0155	0.0147	50	24	8'-10"	8'-5"	7'-4"	7'-1"	7'-1"	6'-5"	--	--	--
	3-5/8"	25EQ (15)	362VS125-15 (25EQ)	0.0155	0.0147	50	12	14'-7"	13'-11"	12'-1"	11'-11"	11'-11"	10'-7"	10'-4"	10'-4"	9'-7"
			362VS125-15 (25EQ)	0.0155	0.0147	50	16	12'-8"	12'-7"	11'-0"	10'-4"	10'-4"	9'-7"	9'-0"	9'-0"	8'-10"
			362VS125-15 (25EQ)	0.0155	0.0147	50	24	10'-4"	10'-4"	9'-7"	8'-5"	8'-5"	8'-5"	6'-7"	6'-7"	6'-7"
	4"	25EQ (15)	400VS125-15 (25EQ)	0.0155	0.0147	50	12	15'-0"	15'-0"	13'-1"	12'-4"	12'-4"	11'-5"	10'-7"	10'-7"	10'-5"
			400VS125-15 (25EQ)	0.0155	0.0147	50	16	13'-0"	13'-0"	11'-11"	10'-7"	10'-7"	10'-5"	9'-2"	9'-2"	9'-2"
			400VS125-15 (25EQ)	0.0155	0.0147	50	24	10'-7"	10'-7"	10'-5"	8'-6"	8'-6"	8'-6"	6'-5"	6'-5"	6'-5"
6"	25EQ (15)	600VS125-15 (25EQ)	0.0155	0.0147	50	12	17'-8"	17'-8"	17'-7"	14'-1"	14'-1"	14'-1"	10'-7"	10'-7"	10'-7"	
		600VS125-15 (25EQ)	0.0155	0.0147	50	16	15'-5"	15'-5"	15'-5" f	10'-7"	10'-7"	10'-7"	7'-11"	7'-11"	7'-11"	
		600VS125-15 (25EQ)	0.0155	0.0147	50	24	10'-7"	10'-7"	10'-7"	7'-0"	7'-0"	7'-0"	--	--	--	
VIPER20	1-5/8"	20EQ (18)	162VS125-18-70 (20EQ)	0.0190	0.0181	70	12	9'-6"	7'-7"	6'-7"	8'-4"	6'-7"	--	7'-7"	6'-0"	--
			162VS125-18-70 (20EQ)	0.0190	0.0181	70	16	8'-7"	6'-11"	6'-0"	7'-7"	6'-0"	--	6'-11"	--	--
			162VS125-18-70 (20EQ)	0.0190	0.0181	70	24	7'-7"	6'-0"	5'-2"	6'-7"	--	--	6'-0"	--	--
	2-1/2"	20EQ (18)	250VS125-18-70 (20EQ)	0.0190	0.0181	70	12	13'-6"	10'-8"	9'-5"	11'-10"	9'-5"	8'-2"	10'-8"	8'-6"	7'-5"
			250VS125-18-70 (20EQ)	0.0190	0.0181	70	16	12'-4"	9'-8"	8'-6"	10'-8"	8'-6"	7'-5"	9'-8"	7'-8"	6'-10"
			250VS125-18-70 (20EQ)	0.0190	0.0181	70	24	10'-8"	8'-6"	7'-5"	9'-5"	7'-5"	6'-6"	8'-4"	6'-10"	--
	3-5/8"	20EQ (18)	362VS125-18-70 (20EQ)	0.0190	0.0181	70	12	17'-8"	14'-1"	12'-4"	15'-6"	12'-4"	10'-8"	14'-1"	11'-2"	9'-10"
			362VS125-18-70 (20EQ)	0.0190	0.0181	70	16	16'-10"	12'-10"	11'-2"	14'-1"	11'-2"	9'-10"	12'-5"	10'-1"	8'-11"
			362VS125-18-70 (20EQ)	0.0190	0.0181	70	24	14'-1"	11'-2"	9'-10"	11'-8"	9'-10"	8'-6"	10'-1"	8'-11"	7'-8"
	4"	20EQ (18)	400VS125-18-70 (20EQ)	0.0190	0.0181	70	12	19'-1"	15'-1"	13'-2"	16'-8"	13'-2"	11'-7"	15'-1"	12'-0"	10'-6"
			400VS125-18-70 (20EQ)	0.0190	0.0181	70	16	17'-4"	13'-10"	12'-0"	15'-1"	12'-0"	10'-6"	13'-1"	10'-11"	9'-6"
			400VS125-18-70 (20EQ)	0.0190	0.0181	70	24	15'-1"	12'-0"	10'-6"	12'-5"	10'-6"	9'-2"	10'-8"	9'-6"	8'-4"
6"	20EQ (18)	600VS125-18-70 (20EQ)	0.0190	0.0181	70	12	25'-8"	20'-5"	17'-10"	21'-11"	17'-10"	15'-7"	19'-0"	16'-2"	14'-1"	
		600VS125-18-70 (20EQ)	0.0190	0.0181	70	16	23'-4"	18'-6"	16'-2"	19'-0"	16'-2"	14'-1"	15'-10"	14'-8"	12'-10"	
		600VS125-18-70 (20EQ)	0.0190	0.0181	70	24	19'-0"	16'-2"	14'-1"	14'-0"	14'-0"	12'-5"	10'-6"	10'-6"	10'-6"	
VIPER 30MIL	1-5/8"	20 (30)	162VS125-30	0.0312	0.0296	33	12	11'-8"	9'-4"	8'-1"	10'-2"	8'-1"	7'-1"	9'-4"	7'-5"	6'-6"
			162VS125-30	0.0312	0.0296	33	16	10'-8"	8'-6"	7'-5"	9'-4"	7'-5"	6'-6"	8'-1" f	6'-8"	--
			162VS125-30	0.0312	0.0296	33	24	9'-4"	7'-5"	6'-6"	7'-8" f	6'-6"	--	6'-7" f	--	--
	2-1/2"	20 (30)	250VS125-30	0.0312	0.0296	33	12	16'-2"	12'-11"	11'-4"	14'-2"	11'-4"	9'-10"	12'-5" f	10'-2"	8'-11"
			250VS125-30	0.0312	0.0296	33	16	14'-8"	11'-8"	10'-2"	12'-5" f	10'-2"	8'-11"	10'-8" f	9'-4"	8'-1"
			250VS125-30	0.0312	0.0296	33	24	12'-5" f	10'-2"	8'-11"	10'-1" f	8'-11"	7'-10"	8'-10" f	8'-1"	7'-1"
	3-5/8"	20 (30)	362VS125-30	0.0312	0.0296	33	12	21'-4" f	17'-2"	15'-0"	17'-5" f	13'-1"	15'-0"	15'-0" f	13'-7"	11'-11"
			362VS125-30	0.0312	0.0296	33	16	18'-5" f	15'-7"	13'-7"	15'-0" f	13'-7"	11'-11"	13'-0" f	12'-5"	10'-10"
			362VS125-30	0.0312	0.0296	33	24	15'-0" f	13'-7"	11'-11"	12'-4" f	11'-11"	10'-5"	10'-7" f	10'-7" f	9'-5"
	4"	20 (30)	400VS125-30	0.0312	0.0296	33	12	22'-6" f	18'-6"	16'-2"	18'-4" f	16'-2"	14'-1"	15'-1" f	14'-8"	12'-11"
			400VS125-30	0.0312	0.0296	33	16	19'-5" f	16'-10"	14'-8"	15'-11" f	14'-8"	12'-11"	13'-8" f	13'-5"	11'-8"
			400VS125-30	0.0312	0.0296	33	24	15'-11" f	14'-8"	12'-11"	13'-0" f	12'-11"	11'-2"	11'-2" f	11'-2" f	10'-2"
6"	20 (30)	600VS125-30	0.0312	0.0296	33	12	28'-2" f	25'-4"	22'-1"	23'-0" f	22'-1"	19'-4"	19'-11" f	19'-11" f	17'-6"	
		600VS125-30	0.0312	0.0296	33	16	24'-5" f	23'-0"	20'-1"	19'-11" f	19'-11" f	17'-6"	17'-2" f	17'-2" f	15'-11"	
		600VS125-30	0.0312	0.0296	33	24	19'-11" f	19'-11" f	17'-6"	16'-4" f	16'-4" f	15'-4"	12'-5" w	12'-5" w	12'-5" w	
VIPER 33MIL	1-5/8"	20 (33)	162VS125-33	0.0346	0.0329	33	12	12'-1"	9'-7"	8'-5"	10'-7"	8'-5"	7'-4"	9'-7"	7'-7"	6'-8"
			162VS125-33	0.0346	0.0329	33	16	11'-0"	8'-8"	7'-7"	9'-7"	7'-7"	6'-8"	8'-8" f	6'-11"	6'-1"
			162VS125-33	0.0346	0.0329	33	24	9'-7"	7'-7"	6'-8"	8'-2" f	6'-8"	--	7'-1" f	6'-1"	--
	2-1/2"	20 (33)	250VS125-33	0.0346	0.0329	33	12	16'-10"	13'-4"	11'-7"	14'-8"	11'-7"	10'-2"	13'-4" f	10'-7"	9'-2"
			250VS125-33	0.0346	0.0329	33	16	15'-4"	12'-1"	10'-7"	13'-4" f	10'-7"	9'-2"	11'-6" f	9'-7"	8'-5"
			250VS125-33	0.0346	0.0329	33	24	13'-4" f	10'-7"	9'-2"	10'-10" f	9'-2"	8'-1"	9'-5" f	8'-5"	7'-4"
	3-5/8"	20 (33)	362VS125-33	0.0346	0.0329	33	12	22'-5"	17'-10"	15'-6"	18'-10" f	15'-6"	13'-7"	16'-4" f	14'-1"	12'-4"
			362VS125-33	0.0346	0.0329	33	16	19'-11" f	16'-1"	14'-1"	16'-4" f	14'-1"	12'-4"	14'-1" f	12'-10"	11'-2"
			362VS125-33	0.0346	0.0329	33	24	16'-4" f	14'-1"	12'-4"	13'-4" f	12'-4"	10'-10"	11'-6" f	11'-2"	9'-10"
	4"	20 (33)	400VS125-33	0.0346	0.0329	33	12	24'-2"	19'-2"	16'-10"	19'-10" f	16'-10"	14'-7"	17'-2" f	15'-2"	13'-4"
			400VS125-33	0.0346	0.0329	33	16	21'-0" f	17'-5"	15'-2"	17'-2" f	15'-2"	13'-4"	14'-11" f	13'-10"	12'-1"
			400VS125-33	0.0346	0.0329	33	24	17'-2" f	15'-2"	13'-4"	14'-0" f	13'-4"	11'-7"	12'-1" f	12'-1"	10'-7"
6"	20 (33)	600VS125-33	0.0346	0.0329	33	12	30'-5" f	26'-4"	23'-0"	24'-10" f	23'-0"	20'-1"	21'-6" f	20'-11"	18'-2"	
		600VS125-33	0.0346	0.0329	33	16	26'-4" f	23'-11"	20'-11"	21'-6" f	20'-11"	18'-2"	18'-7" f	18'-7" f	16'-7"	
		600VS125-33	0.0346	0.0329	33	24	21'-6" f	20'-11"	18'-2"	17'-6" f	17'-6" f	15'-11"	15'-2" f	15'-2" f	14'-6"	

"f"-flexure controls; "s"-shear controls; "w"-web crippling controls. No letter next to the number means deflection controls.

- Notes:**
- Limiting heights are in accordance with AISI S100-16/S2-20 using all steel non-composite design.
 - Limiting heights are established by considering flexure, shear, web crippling, and deflection.
 - For bending, studs are assumed to be adequately braced to develop full allowable moment. Studs are considered fully braced when unbraced length is less than the Lu. See section properties table on page 5 for Lu values.
 - For web crippling, when h/t ≤ 200, the web crippling values are computed based on section G6 of AISI S100-16/S2-20, when h/t > 200, the web crippling values are based on testing with a bearing length of 1".
 - No web stiffeners are required for studs with h/t < 200, web crippling and shear values have been confirmed by testing.
 - The factory punchouts are in accordance with AISI standards. The distance from the center of the last punchout to the end of the stud is 12".
 - Use non-composite tables when 1/2 inch gypsum board, horizontal board, RC channel, furring channel, or sound clips are used.
 - Review fire rated assemblies for additional requirements.



NON-COMPOSITE LIMITING HEIGHTS – BRACED 48" O.C.



MODEL NO.	DEPTH	GAUGE (mil.)	MEMBER	DESIGN (in)	MIN. (in)	YIELD (ksi)	SPACING O.C. (in)	5 PSF			7.5 PSF			10 PSF		
								L/120	L/240	L/360	L/120	L/240	L/360	L/120	L/240	L/360
VIPER25	1-5/8"	25EQ (15)	162VS125-15 (25EQ)	0.0155	0.0147	50	12	8'-8" f	7'-6" f	6'-7" f	7'-1" f	6'-7" f	--	6'-1" f	6'-0" f	--
			162VS125-15 (25EQ)	0.0155	0.0147	50	16	7'-6" f	6'-10" f	6'-0" f	6'-1" f	6'-0" f	--	--	--	--
			162VS125-15 (25EQ)	0.0155	0.0147	50	24	6'-1" f	6'-0" f	--	--	--	--	--	--	--
	2-1/2"	25EQ (15)	250VS125-15 (25EQ)	0.0155	0.0147	50	12	11'-10" f	10'-7" f	9'-2" f	9'-7" f	9'-2" f	8'-1" f	8'-5" f	8'-5" f	7'-4" f
			250VS125-15 (25EQ)	0.0155	0.0147	50	16	10'-2" f	9'-7" f	8'-5" f	8'-5" f	8'-5" f	7'-4" f	7'-2" f	7'-2" f	6'-8" f
			250VS125-15 (25EQ)	0.0155	0.0147	50	24	8'-5" f	8'-5" f	7'-4" f	6'-8" w	6'-8" w	6'-5" f	--	--	--
	3-5/8"	25EQ (15)	362VS125-15 ^s (25EQ)	0.0155	0.0147	50	12	13'-2" f	13'-2" f	12'-1" f	10'-10" f	10'-10" f	10'-7" f	9'-4" f	9'-4" f	9'-4" f
			362VS125-15 ^s (25EQ)	0.0155	0.0147	50	16	10'-2" f	9'-7" f	8'-5" f	9'-4" f	9'-4" f	9'-4" f	7'-10" w	7'-10" w	7'-10" w
			362VS125-15 ^s (25EQ)	0.0155	0.0147	50	24	9'-4" f	9'-4" f	9'-4" f	6'-11" w	6'-11" w	6'-11" w	--	--	--
	4"	25EQ (15)	400VS125-15 ^s (25EQ)	0.0155	0.0147	50	12	13'-10" f	13'-10" f	13'-1" f	11'-4" f	11'-4" f	11'-4" f	9'-10" f	9'-10" f	9'-10" f
			400VS125-15 ^s (25EQ)	0.0155	0.0147	50	16	12'-0" f	12'-0" f	11'-11" f	9'-10" f	9'-10" f	9'-10" f	7'-5" w	7'-5" w	7'-5" w
			400VS125-15 ^s (25EQ)	0.0155	0.0147	50	24	9'-10" f	9'-10" f	9'-10" f	6'-6" w	6'-6" w	6'-6" w	--	--	--
6"	25EQ (15)	600VS125-15 (25EQ)	0.0155	0.0147	50	12	14'-1" w	14'-1" w	14'-1" w	9'-5" w	9'-5" w	9'-5" w	7'-1" w	7'-1" w	7'-1" w	
		600VS125-15 (25EQ)	0.0155	0.0147	50	16	10'-7" w	10'-7" w	10'-7" w	7'-1" w	7'-1" w	7'-1" w	--	--	--	
		600VS125-15 (25EQ)	0.0155	0.0147	50	24	7'-1" w	7'-1" w	7'-1" w	--	--	--	--	--	--	
VIPER20	1-5/8"	20EQ (18)	162VS125-18-70 (20EQ)	0.0190	0.0181	70	12	9'-6" f	7'-7" f	6'-7" f	8'-4" f	6'-7" f	--	7'-5" f	6'-0" f	--
			162VS125-18-70 (20EQ)	0.0190	0.0181	70	16	8'-7" f	6'-11" f	6'-0" f	7'-5" f	6'-0" f	--	6'-5" f	--	--
			162VS125-18-70 (20EQ)	0.0190	0.0181	70	24	7'-5" f	6'-0" f	5'-2" f	6'-0" f	--	--	--	--	--
	2-1/2"	20EQ (18)	250VS125-18-70 (20EQ)	0.0190	0.0181	70	12	13'-6" f	10'-8" f	9'-5" f	11'-10" f	9'-5" f	8'-2" f	10'-8" f	8'-6" f	7'-5" f
			250VS125-18-70 (20EQ)	0.0190	0.0181	70	16	12'-4" f	9'-8" f	8'-6" f	10'-8" f	8'-6" f	7'-5" f	9'-4" f	7'-8" f	6'-10" f
			250VS125-18-70 (20EQ)	0.0190	0.0181	70	24	10'-8" f	8'-6" f	7'-5" f	8'-10" f	7'-5" f	6'-6" f	7'-7" f	6'-10" f	--
	3-5/8"	20EQ (18)	362VS125-18-70 (20EQ)	0.0190	0.0181	70	12	17'-1" f	14'-1" f	12'-4" f	14'-0" f	12'-4" f	10'-8" f	12'-1" f	11'-2" f	9'-10" f
			362VS125-18-70 (20EQ)	0.0190	0.0181	70	16	14'-10" f	12'-10" f	11'-2" f	12'-1" f	11'-2" f	9'-10" f	10'-6" f	10'-1" f	8'-11" f
			362VS125-18-70 (20EQ)	0.0190	0.0181	70	24	12'-1" f	11'-2" f	9'-10" f	9'-11" f	9'-10" f	8'-6" f	8'-7" f	8'-7" f	7'-8" f
	4"	20EQ (18)	400VS125-18-70 (20EQ)	0.0190	0.0181	70	12	18'-1" f	15'-1" f	13'-2" f	14'-10" f	13'-2" f	11'-7" f	12'-10" f	12'-0" f	10'-6" f
			400VS125-18-70 (20EQ)	0.0190	0.0181	70	16	15'-8" f	13'-10" f	12'-0" f	12'-10" f	12'-0" f	10'-6" f	11'-1" f	10'-11" f	9'-6" f
			400VS125-18-70 (20EQ)	0.0190	0.0181	70	24	12'-10" f	12'-0" f	10'-6" f	10'-6" f	10'-6" f	9'-2" f	9'-1" f	9'-1" f	8'-4" f
6"	20EQ (18)	600VS125-18-70 (20EQ)	0.0190	0.0181	70	12	23'-10" f	20'-5" f	17'-10" f	19'-6" f	17'-0" f	15'-7" f	16'-10" f	16'-2" f	14'-1" f	
		600VS125-18-70 (20EQ)	0.0190	0.0181	70	16	20'-7" f	18'-6" f	16'-2" f	16'-10" f	16'-2" f	14'-1" f	14'-7" f	14'-7" f	12'-10" f	
		600VS125-18-70 (20EQ)	0.0190	0.0181	70	24	16'-10" f	16'-2" f	14'-1" f	16'-10" f	13'-10" f	12'-5" f	10'-6" f	10'-6" f	10'-6" f	
VIPER 30MIL	1-5/8"	20 (30)	162VS125-30	0.0312	0.0296	33	12	11'-10" f	9'-4" f	8'-2" f	10'-4" f	8'-2" f	7'-1" f	8'-11" f	7'-5" f	6'-6" f
			162VS125-30	0.0312	0.0296	33	16	10'-8" f	8'-6" f	7'-5" f	8'-11" f	7'-5" f	6'-6" f	7'-8" f	6'-8" f	--
			162VS125-30	0.0312	0.0296	33	24	8'-11" f	7'-5" f	6'-6" f	7'-4" f	6'-6" f	--	6'-4" f	--	--
	2-1/2"	20 (30)	250VS125-30	0.0312	0.0296	33	12	16'-4" f	12'-11" f	11'-4" f	13'-7" f	11'-4" f	9'-11" f	11'-10" f	10'-4" f	9'-0" f
			250VS125-30	0.0312	0.0296	33	16	14'-5" f	11'-8" f	10'-4" f	11'-10" f	10'-4" f	9'-0" f	10'-2" f	9'-4" f	8'-1" f
			250VS125-30	0.0312	0.0296	33	24	11'-10" f	10'-4" f	9'-0" f	9'-7" f	9'-0" f	7'-10" f	8'-4" f	8'-1" f	7'-1" f
	3-5/8"	20 (30)	362VS125-30	0.0312	0.0296	33	12	20'-0" f	17'-2" f	15'-0" f	16'-4" f	15'-0" f	13'-1" f	14'-2" f	13'-8" f	11'-11" f
			362VS125-30	0.0312	0.0296	33	16	17'-4" f	15'-7" f	13'-8" f	14'-2" f	13'-8" f	11'-11" f	12'-4" f	12'-4" f	10'-10" f
			362VS125-30	0.0312	0.0296	33	24	14'-2" f	13'-8" f	11'-11" f	11'-7" f	11'-7" f	10'-5" f	10'-0" f	10'-0" f	9'-6" f
	4"	20 (30)	400VS125-30	0.0312	0.0296	33	12	21'-1" f	18'-7" f	16'-4" f	17'-2" f	16'-4" f	14'-2" f	14'-11" f	14'-10" f	12'-11" f
			400VS125-30	0.0312	0.0296	33	16	18'-4" f	16'-11" f	14'-10" f	14'-11" f	14'-10" f	12'-11" f	12'-11" f	12'-11" f	11'-8" f
			400VS125-30	0.0312	0.0296	33	24	14'-11" f	14'-10" f	12'-11" f	12'-2" f	12'-2" f	11'-4" f	10'-7" f	10'-7" f	10'-2" f
6"	20 (30)	600VS125-30	0.0312	0.0296	33	12	28'-0" f	25'-6" f	22'-4" f	22'-10" f	22'-4" f	19'-6" f	19'-10" f	19'-10" f	17'-8" f	
		600VS125-30	0.0312	0.0296	33	16	24'-2" f	23'-2" f	20'-2" f	19'-10" f	19'-10" f	17'-8" f	17'-1" f	17'-1" f	16'-1" f	
		600VS125-30	0.0312	0.0296	33	24	19'-10" f	19'-10" f	17'-8" f	15'-7" w	15'-7" w	15'-6" f	11'-8" w	11'-8" w	11'-8" w	
VIPER 33MIL	1-5/8"	20 (33)	162VS125-33	0.0346	0.0329	33	12	12'-2" f	9'-8" f	8'-5" f	10'-7" f	8'-5" f	7'-5" f	9'-6" f	7'-8" f	6'-8" f
			162VS125-33	0.0346	0.0329	33	16	11'-1" f	8'-10" f	7'-8" f	9'-6" f	7'-8" f	6'-8" f	8'-2" f	7'-0" f	6'-1" f
			162VS125-33	0.0346	0.0329	33	24	9'-6" f	7'-8" f	6'-8" f	7'-8" f	6'-8" f	--	6'-8" f	6'-1" f	--
	2-1/2"	20 (33)	250VS125-33	0.0346	0.0329	33	12	16'-11" f	13'-5" f	11'-8" f	14'-5" f	11'-8" f	10'-2" f	12'-6" f	10'-7" f	9'-4" f
			250VS125-33	0.0346	0.0329	33	16	15'-4" f	12'-2" f	10'-7" f	12'-6" f	10'-7" f	9'-4" f	10'-10" f	9'-7" f	8'-5" f
			250VS125-33	0.0346	0.0329	33	24	12'-6" f	10'-7" f	9'-4" f	10'-2" f	9'-4" f	8'-1" f	8'-10" f	8'-5" f	7'-5" f
	3-5/8"	20 (33)	362VS125-33	0.0346	0.0329	33	12	21'-4" f	17'-10" f	15'-7" f	17'-5" f	15'-7" f	13'-7" f	15'-1" f	14'-1" f	12'-5" f
			362VS125-33	0.0346	0.0329	33	16	18'-5" f	16'-2" f	14'-1" f	15'-1" f	14'-1" f	12'-5" f	13'-0" f	12'-11" f	11'-2" f
			362VS125-33	0.0346	0.0329	33	24	15'-1" f	14'-1" f	12'-5" f	12'-4" f	12'-4" f	10'-10" f	10'-8" f	10'-8" f	9'-10" f
	4"	20 (33)	400VS125-33	0.0346	0.0329	33	12	22'-6" f	19'-4" f	16'-10" f	18'-4" f	16'-10" f	14'-8" f	15'-11" f	15'-4" f	13'-4" f
			400VS125-33	0.0346	0.0329	33	16	19'-5" f	17'-6" f	15'-4" f	15'-11" f	15'-4" f	13'-4" f	13'-10" f	13'-10" f	12'-1" f
			400VS125-33	0.0346	0.0329	33	24	15'-11" f	15'-4" f	13'-4" f	13'-0" f	13'-0" f	11'-8" f	11'-2" f	11'-2" f	10'-7" f
6"	20 (33)	600VS125-33	0.0346	0.0329	33	12	29'-10" f	26'-6" f	23'-1" f	24'-4" f	23'-1" f	20'-2" f	21'-1" f	21'-0" f	18'-5" f	
		600VS125-33	0.0346	0.0329	33	16	25'-10" f	24'-1" f	21'-0" f	21'-1" f	21'-0" f	18'-5" f	18'-4" f	18'-4" f	16'-8" f	
		600VS125-33	0.0346	0.0329	33	24	21'-1" f	21'-0" f	18'-5" f	17'-2" f	17'-2" f	16'-0" f	14'-6" w	14'-6" w	14'-6" w	

"f"-flexure controls; "s"-shear controls; "w"-web crippling controls. No letter next to the number means deflection controls.

Notes:

- Limiting heights are in accordance with AISI S100-16/S2-20 using all steel non-composite design.
- Limiting heights are established by considering flexure, shear, web crippling and deflection.
- Lateral-Torsional buckling moments are based on section F of AISI S100-16/S2-20, with max discrete bracing of 48" o.c.
- For web crippling, when h/t ≤ 200, the web crippling values are computed based on section G6 of AISI S100-16/S2-20, when h/t > 200, the web crippling values are based on testing with a bearing length of 1".
- No web stiffeners are required for studs with h/t < 200, web crippling and shear values have been confirmed by testing.
- The factory punchouts are in accordance with AISI standards. The distance from the center of the last punchout to the end of the stud is 12".
- Use non-composite tables when 1/2 inch gypsum board, horizontal board, RC channel, furring channel, or sound clips are used.
- Review fire rated assemblies for additional requirements.



SELECT MARKETS ONLY (18 mil, 33 ksi)



COMPOSITE LIMITING HEIGHTS – 5/8" TYPE X3

MODEL NO.	DEPTH	GAUGE (mil.)	MEMBER	DESIGN (in)	MIN. (in)	YIELD (ksi)	SPACING O.C. (in)	5 PSF			7.5 PSF			10 PSF		
								L/120	L/240	L/360	L/120	L/240	L/360	L/120	L/240	L/360
VIPER 18MIL	1-5/8"	25 (18)	162VS125-18 (25ga.)	0.0188	0.0179	33	12	12'-10"	10'-7"	9'-4"	11'-3"	9'-3"	8'-2"	10'-3"	8'-5"	--
			162VS125-18 (25ga.)	0.0188	0.0179	33	16	11'-9"	9'-8"	8'-6"	10'-3"	8'-5"	--	9'-4"	--	--
			162VS125-18 (25ga.)	0.0188	0.0179	33	24	10'-3"	8'-5"	--	8'-11"	--	--	8'-2"	--	--
	2-1/2"	25 (18)	250VS125-18 (25ga.)	0.0188	0.0179	33	12	17'-5"	14'-5"	12'-7"	14'-7" f	12'-7"	11'-0"	12'-8" f	11'-5"	9'-8"
			250VS125-18 (25ga.)	0.0188	0.0179	33	16	15'-6" f	13'-1"	11'-6"	12'-8" f	11'-5"	9'-8"	11'-0" f	10'-3"	8'-6"
			250VS125-18 (25ga.)	0.0188	0.0179	33	24	12'-8" f	11'-5"	9'-8"	10'-4" f	9'-8"	8'-1"	8'-11" f	8'-6"	--
	3-5/8"	25 (18)	362VS125-18 (25ga.)	0.0188	0.0179	33	12	21'-7" f	17'-7"	15'-4"	17'-8" f	15'-4"	13'-5"	15'-3" f	13'-11"	12'-2"
			362VS125-18 (25ga.)	0.0188	0.0179	33	16	18'-9" f	15'-11"	13'-11"	15'-3" f	13'-11"	12'-2"	13'-3" f	12'-8"	11'-0"
			362VS125-18 (25ga.)	0.0188	0.0179	33	24	15'-3" f	13'-11"	12'-2"	12'-6" f	12'-2"	10'-6"	10'-10" f	10'-10" f	9'-5"
	4"	25 (18)	400VS125-18 (25ga.)	0.0188	0.0179	33	12	20'-6" f	18'-5"	16'-3"	16'-9" f	16'-1"	14'-2"	14'-6" f	14'-6" f	12'-11"
			400VS125-18 (25ga.)	0.0188	0.0179	33	16	17'-9" f	16'-9"	14'-9"	14'-6" f	14'-6" f	12'-11"	12'-7" f	12'-7" f	11'-9"
			400VS125-18 (25ga.)	0.0188	0.0179	33	24	14'-6" f	14'-6" f	12'-11"	11'-10" f	11'-10" f	11'-2"	10'-3" f	10'-3" f	9'-11"
	6"	25 (18)	600VS125-18 (25ga.)	0.0188	0.0179	33	12	25'-5" f	24'-9"	21'-8"	20'-9" f	20'-9" f	18'-11"	18'-0" f	18'-0" f	17'-2"
			600VS125-18 (25ga.)	0.0188	0.0179	33	16	22'-0" f	22'-0" f	19'-8"	18'-0" f	18'-0" f	17'-2"	15'-7" f	15'-7" f	15'-7" f
			600VS125-18 (25ga.)	0.0188	0.0179	33	24	18'-0" f	18'-0" f	17'-2"	14'-8" f	14'-8" f	14'-8" f	12'-9" f	12'-9" f	12'-9" f

- Notes:**
1. Sheathing, as specified in Section 3.2.2, must be attached to both faces of the wall for the full height of the wall with the long dimension parallel to the studs.
 2. Sheathing must be fastened to the studs with fasteners as specified in Section 3.2.3 and installed per Section 4.2.1.
 3. Placement of joints in the gypsum sheathing must be in accordance with Sections 4.6.3 and 4.6.4 of GA-216 or Section 7.5 of ASTM C840.
 4. The bottom and top tracks are xxxVT125 (solid flange track). A minimum 30 mil slotted flange track (xxxCST250 or xxxSLT250) may be used for the top track.
 5. End-bearing must be a minimum of 1 inch for xxxVT125 (solid flange track) and 1-5/8 inches for xxxCST250 or xxxSLT250 (slotted flange track).
 6. Notes 1, 2, & 3 are referenced in ICC ESR 2620 page 5.
 7. For any other top tracks not listed in note 4, please contact technical services for assistance.

NON-COMPOSITE LIMITING HEIGHTS – FULLY BRACED

MODEL NO.	DEPTH	GAUGE (mil.)	MEMBER	DESIGN (in)	YIELD (ksi)	SPACING O.C. (in)	5 PSF			7.5 PSF			10 PSF			
							L/120	L/240	L/360	L/120	L/240	L/360	L/120	L/240	L/360	
VIPER 18MIL	1-5/8"	25 (18)	162VS125-18 (25ga.)	0.0188	33	12	9' 6"	7' 10"	6' 10"	7' 9"	6' 10"	5' 11"	6' 8"	6' 2"	5' 5"	
			162VS125-18 (25ga.)	0.0188	33	16	8' 3"	7' 1"	6' 2"	6' 8"	6' 2"	5' 5"	5' 10"	5' 7"	4' 11"	
			162VS125-18 (25ga.)	0.0188	33	24	6' 8"	6' 2"	5' 5"	5' 6"	5' 5"	4' 8"	4' 9"	4' 9"	4' 3"	
	2-1/2"	25 (18)	250VS125-18 (25ga.)	0.0188	33	12	12' 5"	10' 10"	9' 5"	10' 1"	9' 5"	8' 3"	8' 9"	8' 7"	7' 6"	
			250VS125-18 (25ga.)	0.0188	33	16	10' 9"	9' 10"	8' 7"	8' 9"	8' 7"	7' 6"	7' 7"	7' 7"	6' 9"	
			250VS125-18 (25ga.)	0.0188	33	24	8' 9"	8' 7"	7' 6"	6' 11"	6' 11"	6' 6"	5' 2"	5' 2"	5' 2"	
	3-5/8"	25 (18)	362VS125-18 (25ga.)	0.0188	33	12	14' 10"	14' 6"	12' 8"	12' 1"	12' 1"	11' 1"	9' 8"	9' 8"	9' 8"	
			362VS125-18 (25ga.)	0.0188	33	16	12' 10"	12' 10"	11' 6"	9' 8"	9' 8"	9' 8"	7' 3"	7' 3"	7' 3"	
			362VS125-18 (25ga.)	0.0188	33	24	9' 8"	9' 8"	9' 8"	6' 5"	6' 5"	6' 5"	4' 10"	4' 10"	4' 10"	
	4"	25 (18)	400VS125-18 (25ga.)	0.0188	33	12	15' 7"	15' 7"	13' 9"	12' 9"	12' 9"	12' 0"	11' 0"	11' 0"	11' 0"	
			400VS125-18 (25ga.)	0.0188	33	16	13' 6"	13' 6"	12' 5"	11' 0"	11' 0"	10' 11"	9' 6"	9' 6"	9' 6"	
			400VS125-18 (25ga.)	0.0188	33	24	11' 0"	11' 0"	10' 11"	9' 0"	9' 0"	9' 0"	7' 9"	7' 9"	7' 9"	
	6"	25 (18)	600VS125-18 (25ga.)	0.0188	33	12	-	-	-	-	-	-	-	-	-	
			600VS125-18 (25ga.)	0.0188	33	16	-	-	-	-	-	-	-	-	-	-
			600VS125-18 (25ga.)	0.0188	33	24	-	-	-	-	-	-	-	-	-	-

"f"-flexure controls; "s"-shear controls; "w"-web crippling controls. No letter next to the number means deflection controls.

- Notes:**
1. Limiting heights are in accordance with AISI S100-16/S2-20 using all steel non-composite design.
 2. Limiting heights are established by considering flexure, shear, web crippling, and deflection.
 3. For bending, studs are assumed to be adequately braced to develop full allowable moment. Studs are considered fully braced when unbraced length is less the Lu. See section properties table on page 5 for Lu values.
 4. For web crippling, when h/t ≤ 200, the web crippling values are computed based on section G6 of AISI S100-16/S2-20, when h/t > 200, the web crippling values are based on testing with a bearing length of 1".
 5. No web stiffeners are required for studs with h/t < 200, web crippling and shear values have been confirmed by testing.
 6. The factory punchouts are in accordance with AISI standards. The distance from the center of the last punchout to the end of the stud is 12".
 7. Use non-composite tables when 1/2 inch gypsum board, horizontal board, RC channel, furring channel, or sound clips are used.



SELECT MARKETS ONLY (18 mil, 33 ksi)

NON-COMPOSITE LIMITING HEIGHTS – BRACED 48” O.C.

MODEL NO.	DEPTH	GAUGE (mil.)	MEMBER	DESIGN (in)	MIN. (in)	YIELD (ksi)	SPACING O.C. (in)	5 PSF			7.5 PSF			10 PSF				
								L/120	L/240	L/360	L/120	L/240	L/360	L/120	L/240	L/360		
VIPER 18MIL	1-5/8"	25 (18)	162VS125-18 (25ga.)	0.0188	0.0179	33	12	8' 11"	7' 10"	6' 10"	7' 4"	6' 10"	5' 11"	6' 4"	6' 2"	5' 5"		
			162VS125-18 (25ga.)	0.0188	0.0179	33	16	7' 9"	7' 1"	6' 2"	6' 4"	6' 2"	5' 5"	5' 6"	5' 6"	4' 11"		
			162VS125-18 (25ga.)	0.0188	0.0179	33	24	6' 4"	6' 2"	5' 5"	5' 2"	5' 2"	4' 8"	4' 6"	4' 6"	4' 3"		
	2-1/2"	25 (18)	250VS125-18 (25ga.)	250VS125-18 (25ga.)	0.0188	0.0179	33	12	12' 1"	10' 10"	9' 5"	9' 11"	9' 5"	8' 3"	8' 7"	8' 7"	7' 6"	
				250VS125-18 (25ga.)	0.0188	0.0179	33	16	10' 6"	9' 10"	8' 7"	8' 7"	8' 7"	7' 6"	7' 5"	7' 5"	6' 9"	
				250VS125-18 (25ga.)	0.0188	0.0179	33	24	8' 7"	8' 7"	7' 6"	6' 11"	6' 11"	6' 6"	5' 2"	5' 2"	5' 2"	
	3-5/8"	25 (18)	362VS125-18 (25ga.)	362VS125-18 (25ga.)	0.0188	0.0179	33	12	15' 1"	14' 6"	12' 8"	12' 4"	12' 4"	11' 1"	9' 8"	9' 8"	9' 8"	
				362VS125-18 (25ga.)	0.0188	0.0179	33	16	13' 1"	13' 1"	11' 6"	9' 8"	9' 8"	9' 8"	7' 3"	7' 3"	7' 3"	
				362VS125-18 (25ga.)	0.0188	0.0179	33	24	9' 8"	9' 8"	9' 8"	6' 5"	6' 5"	6' 5"	4' 10"	4' 10"	4' 10"	
	4"	25 (18)	400VS125-18 (25ga.)	400VS125-18 (25ga.)	0.0188	0.0179	33	12	15' 11"	15' 8"	13' 8"	13' 0"	13' 0"	12' 10"	11' 3"	11' 3"	10' 10"	
				400VS125-18 (25ga.)	0.0188	0.0179	33	16	13' 9"	13' 9"	12' 5"	12' 5"	11' 3"	10' 10"	9' 9"	9' 9"	9' 9"	
				400VS125-18 (25ga.)	0.0188	0.0179	33	24	11' 3"	11' 3"	10' 10"	10' 10"	9' 2"	9' 2"	7' 11"	7' 11"	7' 11"	
	6"	25 (18)	600VS125-18 (25ga.)	600VS125-18 (25ga.)	0.0188	0.0179	33	12	-	-	-	-	-	-	-	-	-	
				600VS125-18 (25ga.)	0.0188	0.0179	33	16	-	-	-	-	-	-	-	-	-	-
				600VS125-18 (25ga.)	0.0188	0.0179	33	24	-	-	-	-	-	-	-	-	-	-

"f"-flexure controls; "s"-shear controls; "w"-web crippling controls. No letter next to the number means deflection controls.

Notes:

- Limiting heights are in accordance with AISI S100-16/S2-20 using all steel non-composite design.
- Limiting heights are established by considering flexure, shear, web crippling and deflection.
- Lateral-Torsional buckling moments are based on section F of AISI S100-16/S2-20, with max discrete bracing of 48" o.c.
- For web crippling, when h/t ≤ 200, the web crippling values are computed based on section G of AISI S100-16/S2-20, when h/t > 200, the web crippling values are based on testing with a bearing length of 1".
- No web stiffeners are required for studs with h/t < 200, web crippling and shear values have been confirmed by testing.
- The factory punchouts are in accordance with AISI standards. The distance from the center of the last punchout to the end of the stud is 12".
- Use non-composite tables when 1/2 inch gypsum board, horizontal board, RC channel, furring channel, or sound clips are used.

ALLOWABLE CEILING SPANS



L/240			4 PSF LATERAL SUPPORT OF COMPRESSION FLANGE						6 PSF LATERAL SUPPORT OF COMPRESSION FLANGE					
MODEL NO.	MEMBER	Fy ksi	Unsupported Joist Spacing (in) O.C.			Midspan Joist Spacing (in) O.C.			Unsupported Joist Spacing (in) O.C.			Midspan Joist Spacing (in) O.C.		
			12	16	24	12	16	24	12	16	24	12	16	24
			VIPER25	162VS125-15 (25EQ)	50	7'-3"f	6'-9"f	6'-0"f	8'-1"	7'-4"	6'-5"	6'-6"f	6'-0"f	5'-5"f
250VS125-15 (25EQ)	50	8'-2"f		7'-7"f	6'-10"f	11'-3"f	10'-4"	9'-0"f	7'-4"f	6'-10"f	6'-2"f	10'-0"	9'-0"f	7'-8"f
362VS125-15 (25EQ)	50	9'-1"f		8'-6"f	7'-8"f	12'-0"f	11'-0"	9'-9"f	8'-3"f	7'-8"f	6'-11"f	10'-8"f	9'-9"f	8'-5"f
400VS125-15 (25EQ)	50	9'-5"f		8'-9"f	7'-10"f	12'-5"f	11'-4"	10'-0"f	8'-6"f	7'-10"f	7'-1"f	11'-0"	10'-0"	8'-9"f
600VS125-15 (25EQ)	50	10'-8"f		9'-11"f	8'-11"f	14'-4"f	13'-2"	11'-8"f	9'-7"f	8'-11"f	8'-1"f	12'-9"f	11'-8"f	8'-10"w
VIPER20	162VS125-18-70 (20EQ)	70	7'-9"f	7'-3"f	6'-6"f	8'-5"	7'-7"	6'-7"	7'-0"f	6'-6"f	5'-10"f	7'-3"f	6'-7"f	5'-8"f
	250VS125-18-70 (20EQ)	70	8'-9"f	8'-1"f	7'-4"f	12'-0"f	10'-10"	9'-5"f	7'-11"f	7'-4"f	6'-7"f	10'-5"f	9'-5"f	8'-2"f
	362VS125-18-70 (20EQ)	70	9'-7"f	8'-11"f	8'-0"f	13'-6"f	12'-6"	11'-1"f	8'-8"f	8'-0"f	7'-3"f	12'-1"f	11'-1"f	9'-10"f
	400VS125-18-70 (20EQ)	70	9'-10"f	9'-2"f	8'-3"f	13'-10"f	12'-9"	11'-5"f	9'-10"f	9'-2"f	8'-3"f	12'-4"f	11'-5"f	10'-2"f
	600VS125-18-70 (20EQ)	70	11'-2"f	10'-4"f	9'-4"f	15'-10"f	14'-8"	13'-1"f	10'-1"f	9'-4"f	8'-5"f	14'-2"f	13'-1"f	11'-8"f
VIPER 30MIL	162VS125-30	33	9'-4"f	8'-7"f	7'-8"f	10'-1"	9'-2"	8'-0"	8'-4"f	7'-8"f	6'-10"f	8'-10"	8'-0"	7'-0"
	250VS125-30	33	10'-4"f	9'-6"f	8'-6"f	13'-11"	12'-8"	11'-1"	9'-2"f	8'-6"f	7'-7"f	12'-2"	11'-1"	9'-8"
	362VS125-30	33	11'-4"f	10'-6"f	9'-5"f	16'-0"f	14'-10"	13'-3"f	10'-2"f	9'-5"f	8'-6"f	14'-4"f	13'-3"f	11'-9"f
	400VS125-30	33	11'-8"f	10'-10"f	9'-8"f	16'-5"f	15'-2"	13'-7"	10'-6"f	9'-8"f	8'-9"f	14'-9"f	13'-7"f	12'-1"f
	600VS125-30	33	13'-1"f	12'-2"f	10'-11"f	18'-10"f	17'-6"	15'-8"	11'-9"f	10'-11"f	9'-10"f	16'-11"f	15'-8"f	14'-1"f
VIPER 33MIL	162VS125-33	33	9'-9"f	8'-11"f	7'-11"f	10'-5"	9'-5"	8'-3"	8'-8"f	7'-11"f	7'-1"f	9'-1"	8'-3"	7'-3"
	250VS125-33	33	10'-9"f	9'-10"f	8'-10"f	14'-5"	13'-1"	11'-5"	9'-7"f	8'-10"f	7'-11"f	12'-7"	11'-5"	10'-0"
	362VS125-33	33	11'-9"f	10'-11"f	9'-9"f	16'-7"f	15'-4"	13'-9"	10'-7"f	9'-9"f	8'-9"f	14'-10"f	13'-9"f	12'-2"f
	400VS125-33	33	12'-1"f	11'-2"f	10'-0"f	17'-0"f	15'-8"	14'-1"f	10'-10"f	10'-0"f	9'-0"f	15'-3"f	14'-1"f	12'-7"f
	600VS125-33	33	13'-6"f	12'-6"f	11'-3"f	19'-5"f	18'-0"	16'-3"f	12'-2"f	11'-3"f	10'-1"f	17'-6"f	16'-3"f	14'-6"f

L/360			4 PSF LATERAL SUPPORT OF COMPRESSION FLANGE						6 PSF LATERAL SUPPORT OF COMPRESSION FLANGE					
MODEL NO.	MEMBER	Fy ksi	Unsupported Joist Spacing (in) O.C.			Midspan Joist Spacing (in) O.C.			Unsupported Joist Spacing (in) O.C.			Midspan Joist Spacing (in) O.C.		
			12	16	24	12	16	24	12	16	24	12	16	24
			VIPER25	162VS125-15 (25EQ)	50	7'-1"	6'-5"	5'-7"	7'-1"	6'-5"	5'-7"	6'-2"	5'-7"	4'-11"
250VS125-15 (25EQ)	50	8'-2"f		7'-7"f	6'-10"f	10'-0"	9'-0"	7'-11"	7'-4"f	6'-10"f	6'-2"f	8'-8"	7'-11"	6'-11"
362VS125-15 (25EQ)	50	9'-1"f		8'-6"f	7'-8"f	12'-0"f	11'-0"	9'-9"	8'-3"f	7'-8"f	6'-11"f	10'-7"f	9'-9"	8'-5"f
400VS125-15 (25EQ)	50	9'-5"f		8'-9"f	7'-10"f	12'-5"f	11'-4"	10'-0"	8'-6"f	7'-10"f	7'-1"f	11'-0"	10'-0"	8'-9"f
600VS125-15 (25EQ)	50	10'-8"f		9'-11"f	8'-11"f	14'-4"f	13'-2"	11'-8"f	9'-7"f	8'-11"f	8'-1"f	12'-9"f	11'-8"f	8'-10"w
VIPER20	162VS125-18-70 (20EQ)	70	7'-6"f	6'-10"f	5'-11"	7'-4"f	6'-8"f	5'-9"	6'-6"f	5'-11"f	5'-2"f	6'-4"f	5'-9"f	5'-0"f
	250VS125-18-70 (20EQ)	70	8'-9"f	8'-1"f	7'-4"f	10'-5"f	9'-6"	8'-3"f	7'-11"f	7'-4"f	6'-7"f	9'-1"f	8'-3"f	7'-2"f
	362VS125-18-70 (20EQ)	70	9'-7"f	9'-11"f	8'-0"f	13'-6"f	12'-6"	11'-0"	8'-8"f	8'-0"f	7'-3"f	12'-1"f	10'-0"	9'-7"f
	400VS125-18-70 (20EQ)	70	9'-10"f	9'-2"f	8'-3"f	13'-10"f	12'-9"	11'-5"f	8'-11"f	8'-3"f	7'-5"f	12'-4"f	11'-5"f	10'-2"f
	600VS125-18-70 (20EQ)	70	11'-2"f	10'-4"f	9'-4"f	15'-10"f	14'-8"	13'-1"f	10'-1"f	9'-4"f	8'-5"f	14'-2"f	13'-1"f	11'-8"f
VIPER 30MIL	162VS125-30	33	8'-10"	8'-0"	7'-0"	8'-10"	8'-0"	7'-0"	7'-8"	7'-0"	6'-1"	7'-8"	7'-0"	6'-1"
	250VS125-30	33	10'-4"f	9'-6"f	8'-6"f	12'-2"	11'-1"	9'-8"	9'-2"f	8'-6"f	7'-7"f	10'-8"	9'-8"	8'-5"
	362VS125-30	33	11'-4"f	10'-6"f	9'-5"f	16'-0"f	14'-9"	12'-11"	10'-2"f	9'-5"f	8'-6"f	14'-2"	12'-11"	11'-3"
	400VS125-30	33	11'-8"f	10'-10"f	9'-8"f	16'-5"f	15'-2"	13'-7"	10'-6"f	9'-8"f	8'-9"f	14'-9"f	13'-7"f	12'-1"f
	600VS125-30	33	13'-1"f	12'-2"f	10'-11"f	18'-10"f	17'-6"	15'-8"	11'-9"f	10'-11"f	9'-10"f	16'-11"f	15'-8"f	14'-1"f
VIPER 33MIL	162VS125-33	33	9'-1"	8'-3"	7'-3"	9'-1"	8'-3"	7'-3"	7'-11"	7'-3"	6'-4"	7'-11"	7'-3"	6'-4"
	250VS125-33	33	10'-9"f	9'-10"f	8'-10"f	12'-7"	11'-5"	10'-0"	9'-7"f	8'-10"f	7'-11"f	11'-0"	10'-0"	8'-9"
	362VS125-33	33	11'-9"f	10'-11"f	9'-9"f	16'-7"f	15'-3"	13'-4"	10'-7"f	9'-9"f	8'-9"f	14'-8"	13'-4"	11'-8"
	400VS125-33	33	12'-1"f	11'-2"f	10'-0"f	17'-0"f	15'-8"	14'-1"f	10'-10"f	10'-0"f	9'-0"f	15'-3"f	14'-1"f	12'-7"f
	600VS125-33	33	13'-6"f	12'-6"f	11'-3"f	19'-5"f	18'-0"	16'-3"f	12'-2"f	11'-3"f	10'-1"f	17'-6"f	16'-3"f	14'-6"f

"f"-flexure controls; "s"-shear controls; "w"-web crippling controls. No letter next to the number means deflection controls.

Notes:

- Ceiling Spans are in accordance with AISI S100-16/S2-20 using all steel non-composite design.
- Ceiling Spans are established by considering flexure, shear, web crippling and deflection.
- For web crippling, when $h/t \leq 200$, the web crippling values are computed based on G6 of AISI S100-16/S2-20. When $h/t > 200$, the web crippling values are based on testing with a bearing length of 1".
- No web stiffeners are required for studs with $h/t < 200$, web crippling and shear values have been confirmed by testing.
- All values are for simple spans, with compression flange either unbraced or braced at midspan.
- Ceiling spans are based on total load of assembly, not including storage or live load for accessible ceilings.
- The factory punchouts are in accordance with AISI standards. The distance from the center of last punchout to the end of the stud is 12".





SCREW ALLOWABLE LOADS (lbs.)

MODEL NO.	DESIGN THICKNESS (in)	MIN. THICKNESS (in)	F _y YIELD (ksi)	F _u TENSILE (ksi)	#6 SCREW (0.138" Dia; 0.25" head)			#8 SCREW (0.164" Dia; 0.3125" head)			#10 SCREW (0.190" Dia; 0.34" head)			C645 SCREW PENETRATION TEST (P,F)
					SHEAR	PULL OUT	PULL OVER	SHEAR	PULL OUT	PULL OVER	SHEAR	PULL OUT	PULL OVER	
VIPER25	0.0155	0.0147	50	65	75 ⁹	30	97	90 ⁹	36	121	93 ⁹	42	132	PASS
VIPER20	0.019	0.0181	70	70	95	52	140	104	62	195	112	72	226	PASS
Viper 18MIL	0.0188	0.0179	33	45	44	24	78	48	29	97	52	33	105	-
VIPER 30MIL	0.0312	0.0296	33	45	95	40	129	103	48	161	111	55	175	-
VIPER 33MIL	0.0346	0.0329	33	45	110	45	143	120	53	178	130	61	194	-

Notes:

- Capacities are in accordance with section J of AISI S100-16/S2-20 Specification.
- Capacities are based on Allowable Strength Design (ASD).
- Screw pull-out capacities are based on listed head diameter.
- Two sheets of equal thickness and tensile strength are assumed in tabulated values.
- When materials of different steel thickness and tensile strength are connected, use the lowest value for shear capacity (tilting and bearing), for pull-out capacity use sheet closest to screw tip and for pull-over capacity use sheet closest to screw head.
- Where multiple fasteners are used, screws are assumed to have a center-to-center spacing of at least 3 times the nominal diameter.
- Screws are assumed to have a center-of-screw to edge-of-steel dimension of at least 1.5 times the nominal diameter of the screw.
- When screws are subjected to combination of shear and tension forces, interaction equation of AISI S100-16/S2-20 Specification section J4.5 shall be used.
- Viper25 shear values are tested per AISI S100, S220 & AISI S905, tests conducted by Structural Testing & Research, Inc.
- Viper20 values are calculated per AISI S100 & S220.

SCREW PENETRATION TESTING (ASTM C 645, ASTM C 1002)

To pass screw penetration tests, studs must be capable of pulling the head of the screw below surface of gypsum board in less than 2 seconds without spin out.

HI-ABUSE/HI-IMPACT – VIPER20				
SHEATHING TYPE AND THICKNESS	STEEL FRAMING	SCREW TYPE	DRILL SPEED (rpm)	PASS/FAIL ASTM-C-1002
USG 5/8" VHI	3-5/8" VIPER20	#6 X 1-1/4" TYPE S SHARP PT	2500	PASS
			4000	PASS
NATIONAL GYPSUM 5/8" HIGH IMPACT	3-5/8" VIPER20	#6 X 1-1/4" TYPE S SHARP PT	2500	PASS
			4000	PASS
NATIONAL GYPSUM 5/8" HIGH ABUSE	3-5/8" VIPER20	#6 X 1-1/4" TYPE S SHARP PT	2500	PASS
			4000	PASS

CEMENT BOARD – VIPER20				
SHEATHING TYPE AND THICKNESS	STEEL FRAMING	SCREW TYPE	DRILL SPEED (rpm)	PASS/FAIL ASTM-C-1002
USG 1/2" Durock®	VIPER20	#9 BUILDDEX ROCK-ON	2500	PASS
			4000	PASS
		#9 PHILLIPS CEMENT BOARD	2500	PASS
			4000	PASS
NATIONAL GYPSUM 5/8" PERMABASE	VIPER20	#9 BUILDDEX ROCK-ON	2500	PASS
			4000	PASS
		#9 PHILLIPS CEMENT BOARD	2500	PASS
			4000	PASS
GYPSUM BOARD – VIPER25 & VIPER20				
1/2" TYPE C 5/8" TYPE X 5/8" TYPE X	VIPER25	#6 X1-1/4" TYPE S SHARP PT	2500	PASS
	VIPER25		2500	PASS
	VIPER20		2500	PASS



VIPER20 24" O.C.

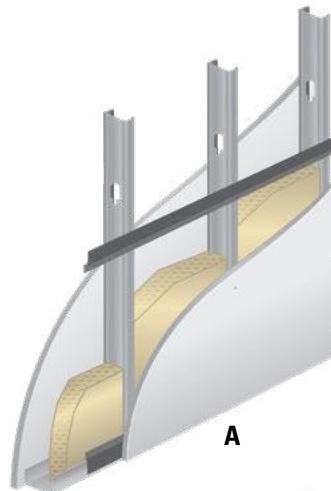
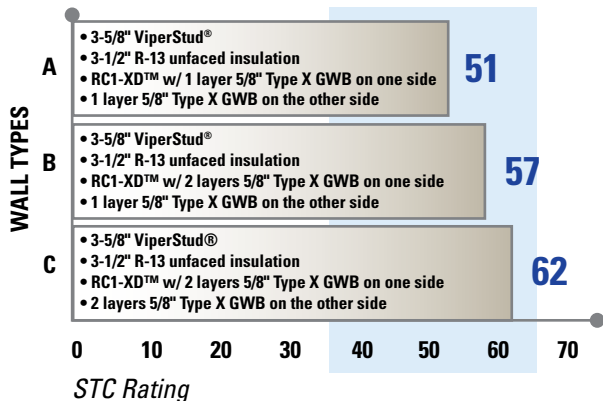

VIPER20 16" O.C.

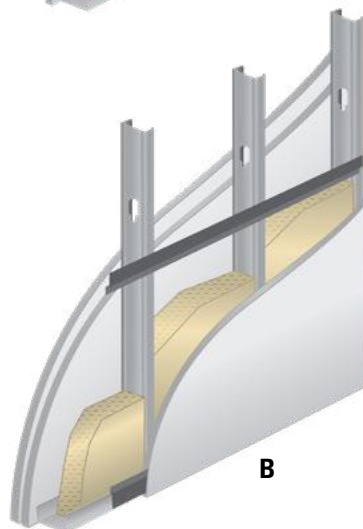
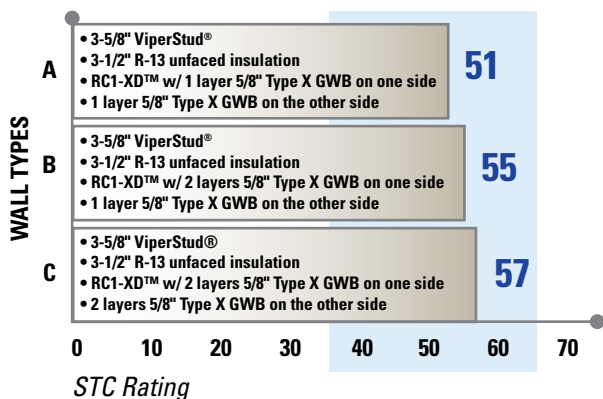

VIPER 33 MIL 24" O.C.

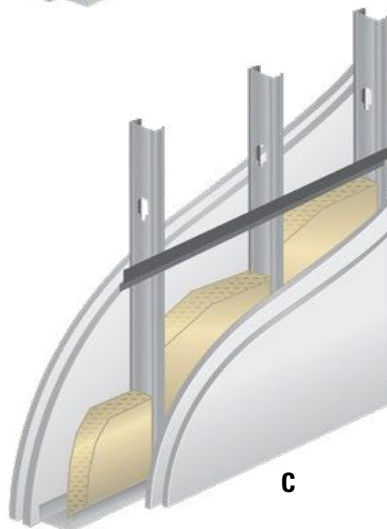
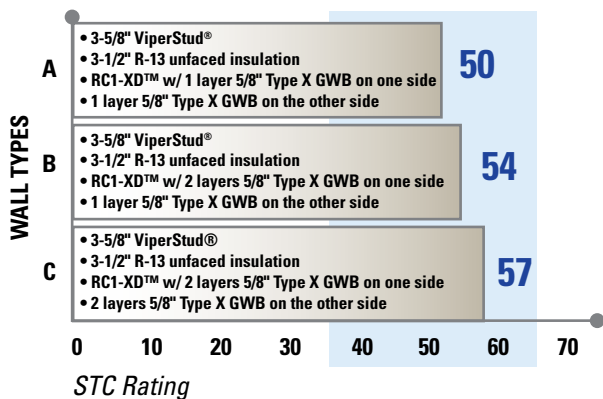

FIRE TESTING DATA (ASTM E 119)

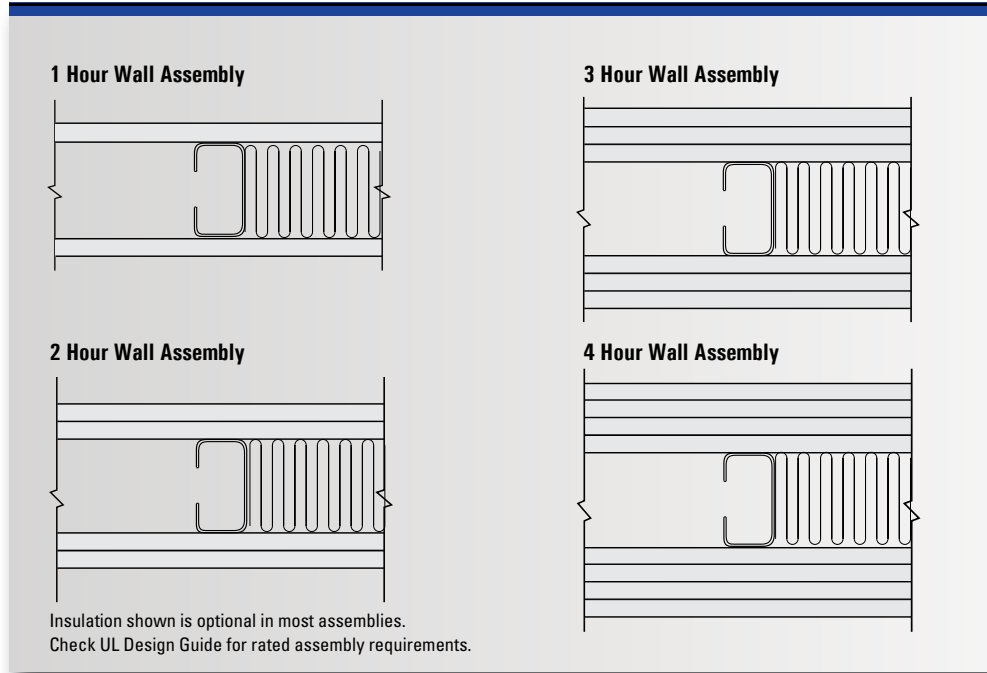

VIPERSTUD® FIRE TESTING DATA (ASTM E119)

UL Design No.	ViperStud Min. Thickness	Wall Rating:	UL Design No.	ViperStud Min. Thickness	Wall Rating:
U375	Viper25	2 HR	V412	Viper20	2 HR
U403	Viper20	2 HR	V416	Viper20	1 HR
U407	Viper25	1/2 or 1 HR	V417	Viper25	1 HR
U408	Viper20	2 HR	V418	Viper20	2 HR
U411	Viper20	2 HR	V419	Viper20	2 HR
U412	Viper20	2 HR	V425	Viper20	1 HR
U419	Viper25	1, 2, 3 or 4 HR	V435	Viper25	1 HR
U421	Viper20	2 HR	V437	Viper20	1 HR Chase
U431	Viper20	4 HR	V438	Viper25	1, 2, 3, or 4 HR
U435	Viper20	3 or 4 HR	V443	Viper20	4 HR
U436	Viper20	1, 2, or 3 HR	V444	Viper20	1 HR
U450	Viper20	1, 3, or 4 HR	V448	Viper25	1 HR
U451	Viper20	1 HR	V449	Viper20	2 HR
U454	Viper20	2 HR	V452	Viper25	1 or 2 HR
U463	Viper20	3 or 4 HR	V469	Viper25	1 or 2 HR Chase
U465	Viper20	1 HR Chase	V476	Viper20	1, 3, or 4 HR
U466	Viper20	1 HR	V486	Viper25	1, 2, or 2-1/2 HR
U471	Viper20	1-1/2 HR	V488	Viper25	1 or 2 HR Chase
U475	Viper20	1, 2, 3 or 4 HR	V489	Viper25	1, 2, 3, or 4 HR
U478	Viper20	3 HR	V496	Viper20	1 or 2 HR Chase
U491	Viper20	2 HR	V498	Viper25	1, 2, 3, or 4 HR
U493	Viper25	1, 2 HR Chase	W411	Viper25	1/2 or 1 HR
U494	Viper20	1 HR	W415	Viper20	1 or 2 HR
U495	Viper20	1 or 2 HR	W423	Viper25	1/2 or 1 HR
U496	Viper20	1 HR	W424	Viper25	1/2 or 1 HR
V410	Viper20	2 HR	W432	Viper25	2 HR
			W433	Viper25	1/2 HR

Note: Check UL Design assembly for minimum stud web width and other requirements. Visit www.cemcosteel.com for more information on fire rated assemblies.



IMPACT TESTING (ASTM C 1629)



Test Summary:

All tests were conducted to ASTM C 1629 standard using Test Method ASTM E 695 for Soft Body Impact Tests and ASTM C 1629 Annex 1 for Hard Body Impact Tests. Each test was repeated 3 times as required by the test method and results reported to the ASTM standard published values for Level Classification.

Test Materials:

Steel Studs – Viper20 Stud and track spaced 16" o.c., do not use ViperTrack25 on Viper20 studs for impact resistant walls. Tests conducted using USG® & National Gypsum® boards.

Testing conducted by IAS Certified 3rd party testing lab Intertek Testing Services.

NATIONAL GYPSUM®

Soft Body Impact Test Single Drop	Board Assembly 3-5/8" NGC Hi-Abuse	Classification Level 2
Soft Body Impact Test Single Drop	Board Assembly 3-5/8" NGC Hi-Impact	Classification Level 3
Soft Body Impact Test Progressive Drop	Board Assembly 3-5/8" NGC Hi-Abuse	Classification Level 1
Soft Body Impact Test Progressive Drop	Board Assembly 3-5/8" NGC Hi-Impact	Classification Level 3
Hard Body Impact Test Single Drop	Board Assembly 3-5/8" NGC Hi-Impact	Classification Level 3

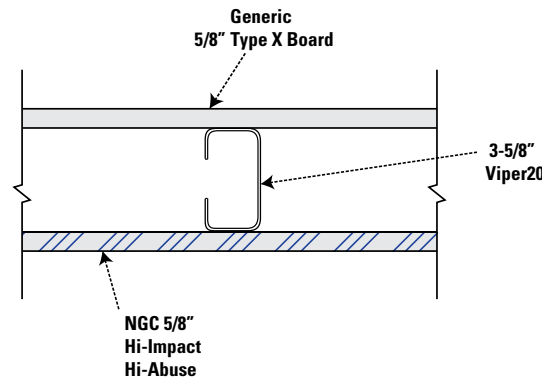

USG®

Soft Body Impact Test Single Drop	Board Assembly 3-5/8" USG FiberRock AR	Classification Level 2
Soft Body Impact Test Progressive Drop	Board Assembly 3-5/8" USG FiberRock VHI	Classification Level 3
Hard Body Impact Test Single Drop	Board Assembly 3-5/8" USG FiberRock AR	Classification Level 1
Hard Body Impact Test Single Drop	Board Assembly 3-5/8" USG FiberRock VHI	Classification Level 3

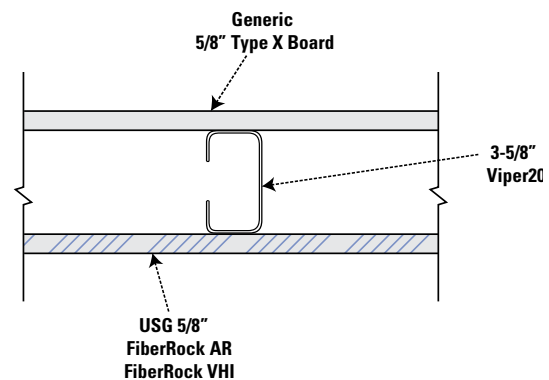

Soft body impact test using ViperStud.

- FiberRock VHI & FiberRock AR are registered trademarks of the United States Gypsum Co. (USG)
- Hi-Abuse, Hi-Impact, & Permabase are registered trademarks of the National Gypsum Co.
- ProRoc & ProRoc Extra are registered trademarks of Certainteed.
- Protecta AR 100 is a registered trademark of Lafarge Gypsum.
- ComfortGuard AR & ComfortGuard IR are registered trademarks of Temple-Inland.
- Dens Brand is a trademark of Georgia Pacific.



CEMCO STRUCTURAL ENGINEERING

The CEMCO Structural Engineering division provides solutions that make sure your buildings are designed to current codes and specifications. Our methodology helps you control costs and keep your projects on schedule. We work closely with owners, designers, and contractors to facilitate efficient project execution.

The structural engineering division uses state-of-the-art software and technologies to streamline the request, design, and issuance processes to cut costs and save time on your projects.

Let the experienced CEMCO Structural Engineering team add value to your project with the following services:

- Thorough review of your architectural plans to determine structural requirements.
- Member sizing and cost estimation for preliminary and conceptual designs.
- Professional, certified engineering shop drawing and calculations.
- Use our project submittal form to submit your project online.

CEMCO STRUCTURAL ENGINEERING 1-2-3 PROCESS

- 1** Review client structural and architectural plans.
- 2** Deliver shop drawings and structural solutions based on the client's needs.
- 3** Provide full engineering support through the life of the project.



CEMCO warrants to Purchaser only the Products to be free from defects in material and workmanship for a period of one year from the date of delivery, subject to CEMCO's standard manufacturing and commercial variations and practice. CEMCO MAKES NO OTHER REPRESENTATIONS OR WARRANTIES TO PURCHASER REGARDING THE PRODUCTS AND EXPRESSLY DISCLAIMS ALL OTHER IMPLIED OR EXPRESS WARRANTIES, INCLUDING ALL WARRANTIES OF MERCHANTABILITY AND FITNESS FOR A PARTICULAR PURPOSE. CEMCO's Product Warranty does not apply to any Product to the extent it has been subject to (1) other than normal wear and tear, or (2) improper installation, alteration, modification, or repair, tampering, negligence, abuse or accident, or (3) improper storage. LIABILITY IS LIMITED TO REPAIR OR REPLACEMENT, AT CEMCO'S OPTION, OF ANY DEFECTIVE PRODUCT. CEMCO will repair and replace, at its option, Products which upon inspection it finds to be defective, based on claims made in writing to CEMCO within a reasonable time after discovery. Products alleged to be defective must be returned, freight prepaid, within thirty (30) days to CEMCO with the return authorization number, obtained from CEMCO, clearly

marked on the outside of the return container for repair or replacement by CEMCO. THE ABOVE WARRANTY SHALL CONSTITUTE PURCHASER'S EXCLUSIVE REMEDY WITH RESPECT TO THE PRODUCTS FURNISHED HEREUNDER. IN NO EVENT SHALL CEMCO BE LIABLE OR RESPONSIBLE TO PURCHASER OR ANY OTHER PERSON FOR ANY SPECIAL, INDIRECT OR CONSEQUENTIAL LOSSES OR DAMAGES, WHETHER BASED ON CONTRACT, TORT, STRICT LIABILITY OR OTHER THEORY OF LAW, EVEN IF CEMCO SHALL HAVE BEEN ADVISED OF THE POSSIBILITY OF ANY LOSS OR DAMAGES, ALL SUCH DAMAGES AND CLAIMS BEING SPECIFICALLY DISCLAIMED. IN NO EVENT SHALL CEMCO'S LIABILITY EXCEED THE PURCHASE PRICE OF THE PRODUCT.

All transactions shall be governed by the laws of the State of California (including, without limitation, the provisions of the California Commercial Code), without giving affect to any conflict of law rule or principle of such state. The United Nations Convention for the International Sale of Goods shall not apply to this agreement.



Expanding Your Solutions

Corporate Headquarters

13191 Crossroads Parkway North, Suite 325, City of Industry, CA 91746

P: 800.775.2362 | **F:** 626.330.7598

Southern California Manufacturing Facility

263 North Covina Lane, City of Industry, CA 91746

P: 800.775.2362 | **F:** 626.330.7598

Northern California Manufacturing Facility

1001-A Pittsburg Antioch Hwy, Pittsburg, CA 94565

P: 925.473.9340 | **F:** 925.473.9341

Commerce City Colorado Manufacturing Facility

9410 Heinz Way, Commerce City, CO 80640

P: 303.572.3626 | **F:** 303.572.3627

Fort Worth Texas Manufacturing Facility

8600 Will Rogers Blvd, Fort Worth, TX 76140

P: 817.568.1525 | **F:** 817.568.2759

www.cemcosteel.com

