



BXUV.P546 -

Design/System/Construction/Assembly Usage Disclaimer

- Authorities Having Jurisdiction should be consulted in all cases as to the particular requirements covering the installation and use of UL Certified products, equipment, system, devices, and materials.
- Authorities Having Jurisdiction should be consulted before construction.
- Fire resistance assemblies and products are developed by the design submitter and have been investigated by UL for compliance with applicable requirements. The published information cannot always address every construction nuance encountered in the field.
- When field issues arise, it is recommended the first contact for assistance be the technical service staff provided by the product manufacturer noted for the design. Users of fire resistance assemblies are advised to consult the general Guide Information for each product category and each group of assemblies. The Guide Information includes specifics concerning alternate materials and alternate methods of construction.
- Only products which bear UL's Mark are considered Certified.

BXUV - Fire Resistance Ratings - ANSI/UL 263 Certified for United States

BXUV7 - Fire Resistance Ratings - CAN/ULC-S101 Certified for Canada

See General Information for Fire-resistance Ratings - ANSI/UL 263 Certified for United States
Design Criteria and Allowable Variances

See General Information for Fire Resistance Ratings - CAN/ULC-S101 Certified for Canada
Design Criteria and Allowable Variances

Design No. P546

October 23, 2018

Restrained Assembly Rating — 1 Hr.

Unrestrained Assembly Rating — 1 Hr.

Unrestrained Beam Rating — 1 Hr.

This design was evaluated using a load design method other than the Limit States Design Method (e.g., Working Stress Design Method). For jurisdictions employing the Limit States Design Method, such as Canada, a load restriction factor shall be used — See Guide BXUV or BXUV7

*** Indicates such products shall bear the UL or cUL Certification Mark for jurisdictions employing the UL or cUL Certification (such as Canada), respectively.**

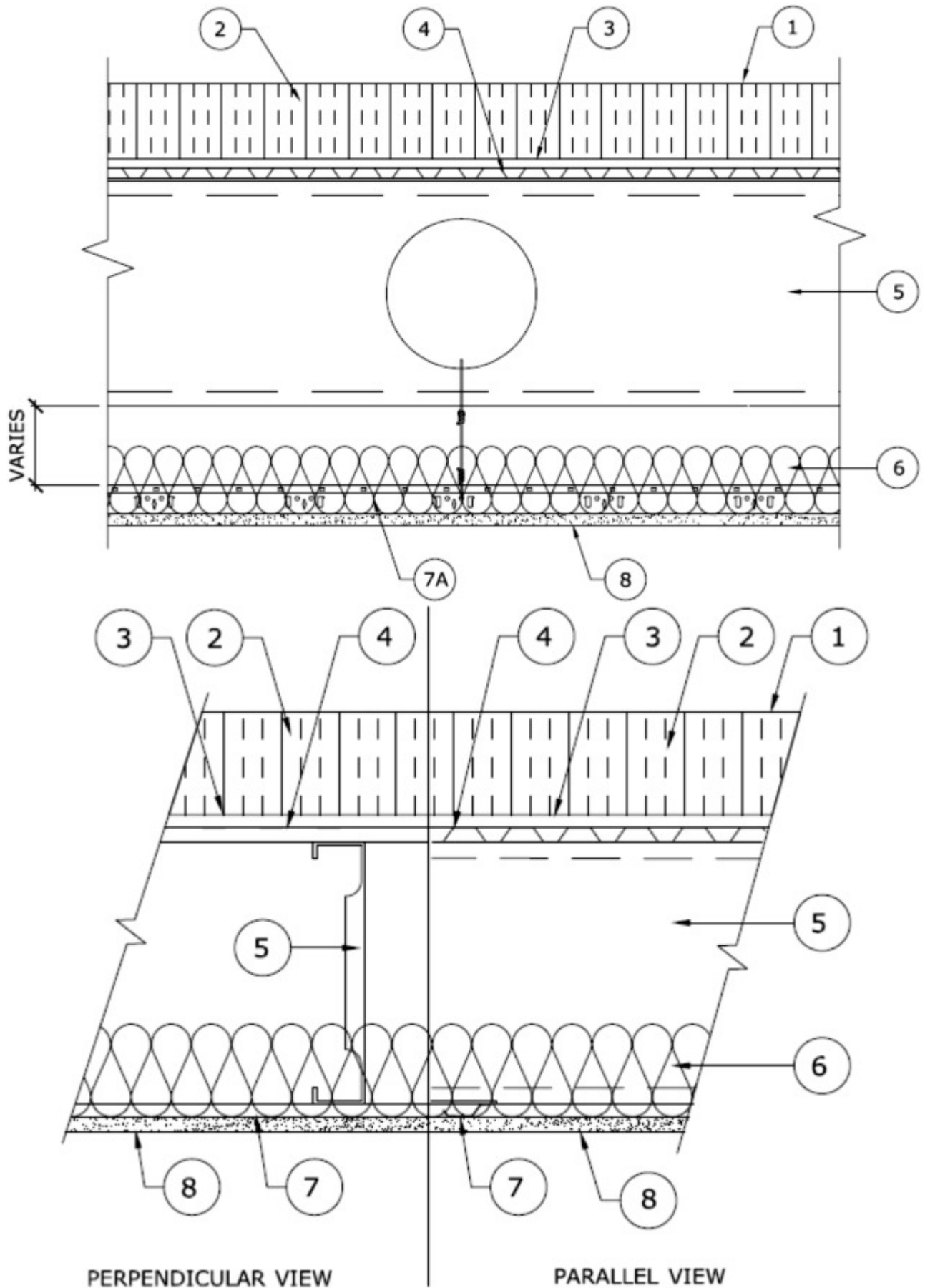

1. **Roof Covering*** — Consisting of hot-mopped or cold-application materials compatible with insulation(s) described herein which provide Class A, B or C coverings. See Roofing Materials and Systems Directory-Roof Covering Materials (TEVT).

1A. **Roofing Membrane*** — (Not Shown) — In lieu of Item 1, single-ply membrane that is either ballasted, adhered or mechanically attached to the insulation(s) described herein as permitted under the respective company's Classification. See Fire Resistance Directory-Roofing Membranes (CHCI) Category.

1B. **Metal Roof Deck Panels*** — In Lieu of or in addition to Items 1 and 1A, the roof covering may consist of mechanically fastened galv or painted steel roof deck panels. Panels may be installed above a steel purlin assembly per metal roof deck manufacturer's specifications. Steel purlin assembly to be installed transverse to steel roof joists (Item 5). A line of sealant or tape may be used at panel side and end laps. See Metal Roof Deck Panels Category in the Roofing Materials and Systems Directory (TJPV) or Fire Resistance Directory (CETW) for names of manufacturers.

2. **Roof Insulation — Foamed Plastic*** — Any polyisocyanurate foamed plastic insulation boards or polyurethane spray foam bearing the UL Classification Marking. Min thickness is 1 in., with no limit on max overall thickness. Boards installed over the gypsum sheathing (Item 3) with the end-joints staggered in adjacent rows. When applied in more than one layer, each layer of board to be offset in both directions from layer below in order to lap all joints. Boards loosely laid, adhered or mechanically fastened to the gypsum sheathing and steel roof deck (Item 4). Spray foam plastic applied directly to gypsum sheathing. See Foamed Plastic (CCVW) Category in the Fire Resistance Directory.

2A. **Roof Insulation — Foamed Plastic*** — (Not Shown) — As an alternate to Item 2 —Any polystyrene foamed plastic insulation boards bearing the UL Classification Marking. Min thickness is 1 in., with no limit on max overall thickness. Boards installed over the gypsum sheathing (Item 3), with the end-joints staggered in adjacent rows. When applied in more than one layer, each layer or board to be offset in both directions from layer below in order to lap all joints. Boards loosely laid, adhered or mechanically fastened to gypsum sheathing and steel roof deck (Item 4). See Foamed Plastic (BRYX) category in the Building Materials Directory or Foamed Plastic (CCVW) category in the Fire Resistance Directory.

2B. **Roof Insulation — Mineral and Fiber Boards*** — (Not Shown) — As an alternate to Item 2 — Mineral wool, glass fiber or perlite insulation boards, 24 by 48 in. min size, applied in one or more layers. Min thickness is 1 in., with no limit on max overall thickness. Boards installed over the gypsum sheathing (Item 3), with the end-joints staggered in adjacent rows. When applied in more than one layer, each layer of board to be offset in both directions from layer below in order to lap all joints. Boards loosely laid, adhered or mechanically fastened to gypsum sheathing and steel roof deck (Item 4). See Mineral and Fiber Boards (BQXR) Category in the Building Materials Directory or Mineral and Fiber Boards (CERZ) Category in the Fire Resistance Directory.

3. **Gypsum Board*** — Nom 1/2 or 5/8 in. thick gypsum board, applied perpendicular to steel deck. End-joists to occur over crests of steel roof deck with end-joints staggered in adjacent rows. Boards loosely laid, adhered or mechanically attached to steel roof deck (Item 4). See Gypsum Board (BWFR) Category in the Building Materials Directory or Roofing Systems (TGFU) in the Roofing Material Directory or Gypsum Board (CKNX) Category in the Fire Resistance Directory.

UNITED STATES GYPSUM CO — Type FRX-G.

4. **Steel Roof Deck** — Nom 30 in. wide, corrugated or fluted, min 22 MSG galv steel, min 9/16 in. deep with 2-1/2 in. corrugation pitch. The deck shall be attached to each steel joist with No. 8-18 by 5/8 in. long self-drilling steel screws located at the side laps of each unit and at the center of each unit, edges at steel channel attached 8 in. OC. Units shall be overlapped at ends a min of 1-1/2 in.

5. **Structural Steel Members*** — The proprietary joists are channel-shaped, min 9-1/4 in. deep. Joists fabricated from min No. 16 MSG galv steel. Joists spaced max 24 in. OC. Joists attached to joist rim with three 3/4 in. long self-drilling #10-16 TEK screws through tab to the outside of the web. At joist rim splices bearing on supports, joists rims are connected using an overlapping section of a 12 in. long splice plate (a joist piece), with four 3/4 in. long self-drilling #10-16 TEK screws to each rim piece.

CLARKDIETRICH BUILDING SYSTEMS — Type TDJ or TDW floor joists, TD rim joist

5A. **Joist Bridging** — Not shown — For use with Item 5. Installed immediately after joists are erected and before construction loads are applied. The bridging, 21/2TDSB18, consisting of No. 18 MSG galv steel, 2-1/2 in. wide by 21-3/4 in. long structural bridging staggered between the steel joists attached to the bottom joist flange with one 3/4 in. long self-drilling #10-16 TEK

screw at each end tab of bridging. Solid bridging consisting of cut to length joist sections placed between outer joists and at center joist with 8 ft OC max spacing. Solid bridging are screw-attached at joist web using EasyClip™ S-Series S547 (which is a 1-1/2 in. by 1-1/2 in. by 7 in. long, 16 MSG, min 50 ksi support clip) with two 3/4 in. long self-drilling #10-16 TEK screws per leg on one side and the other side with an EasyClip™ E-Series E547 (which is a 4 in. by 1-1/2 in. by 7 in. long, 16 MSG, min 50 ksi support clip) with two 3/4 in. long self-drilling #10-16 TEK screws per leg.

5B. Structural Steel Members* — As an alternate to Item 5. JoistRite channel-shaped joists, min 9-1/4 in. deep with min 2 in. wide flanges and 3/4 in. long stiffening flanges. The web of each joist is provided with 3/4 in. deep lip-reinforced trapezoidal cutouts as shown in the illustration. JoistRite rim track, min 9-3/8 in. deep with min 1-1/2 in. top flange and min 2-5/16 in. bottom flange. The joists and rim tracks are fabricated from min 16 MSG galv steel. Joists spaced max 24 in. OC. Floor joists attached to rim track using channel-shaped steel web stiffeners. At rim track splices bearing on supports, rim tracks are connected using an overlapping section of a 12 in. long splice plate, with four 3/4 in. long self-drilling #10 screws to each rim piece.

MARINO/WARE, DIV OF WARE INDUSTRIES INC — Type JR JoistRite floor joists, Type JT JoistRite rim track

5C. Blocking & Bridging — For use with Item 5B. Installed before construction loads are applied. The blocking consists of JoistRite solid blocking placed between each joist. Blocking attached to the top and bottom joist flanges with one #10 3/4 in. long self-drilling screw at each end tab of blocking. Blocking is fabricated from min 18 MSG galv steel, min 1-15/16 in. flanges, having the same depth as the joists. In addition, bridging consists of 1/2 in. by 1-1/2 in. cold-rolled channel, min No. 16 GA, attached to the bottom flanges of the joists and blocking. Cold-rolled channel attached to each blocking bottom flange with four #10 3/4 in. long self-drilling screws and to joist bottom flange with two screws.

5D. Web Stiffeners — Not shown — For use with Item 5B. JoistRite web stiffeners, min 3-5/8 in. wide with min 9/16 in. flange and min 1-1/4 in. flange, having the same depth as the joists. Fabricated from min 16 MSG galv steel. Secured to each joist and track with #10 3/4 in. long self-drilling screws.

5E. Structural Steel Members* — As an alternate to Item 5. The joists are channel-shaped, 9-1/4 in. min depth with min. 2 in. wide flanges. Joists are fabricated from min No. 16 MSG galv steel. Joists spaced max 24 in. OC. Joists attached to rim joist with a minimum of three #10 3/4 in. long self-drilling screws at the rim track clip to the outside of the web joist, and a #10 1/2 in. long screw through the top and bottom flange of the joists to the top and bottom flange of the rim track. At rim joist splices bearing on supports, rim joists are connected using an overlapping section of a 12 in. long splice plate (a joist piece), with a minimum of six 3/4 in. long self-drilling #10 screws to each rim piece.

CALIFORNIA EXPANDED METAL PRODUCTS CO — Type SSCJ floor joists, SSRT rim tracks or Type SSTT rim joists. When Type SSTT rim joists are used, secured to preformed clip tabs in accordance with manufacturers installation instructions.

6. Batts and Blankets* — Any glass fiber insulation bearing the UL Classification Marking as to Surface Burning Characteristics and/or Fire Resistance, having a min thickness of 3-1/2 in. and a maximum thickness of 6-1/4 in. Min density of 0.5 pcf. The insulation shall be fitted in the concealed space, draped over the resilient channel (Item 7) or steel frame members (Item 7A) and gypsum board (Item 8) ceiling membrane.

7. Resilient Channels — 1/2 in. deep, formed of 25 MSG galv steel, spaced a maximum of 12 in. OC, installed perpendicular to the joists. Channels oriented opposite at wallboard butt joints (spaced 6 in. OC) as shown in the above illustration. Channel splices overlapped 4 in. beneath steel joists. Channels secured to each joist with 1/2 in. Type S-12 low profile screws.

7A. Alternate Steel Framing Members* — (Not Shown) - As an alternate to Item 7, main runners, cross tees, cross channels and wall angle as listed below:

a. **Main Runners** — Nom 10 or 12 ft long, 15/16 in. or 1-1/2 in. wide face, spaced 4 ft. OC. Main runners suspended by min 12 SWG galv steel hanger wires spaced 48 in. OC. Hanger wires to be located adjacent to main runner/cross tee intersections. Hanger wires inserted through holes drilled through web of joists and twist-tied.

b. **Cross Tees** — Nom 4 ft long, 1-1/2 in. wide face, installed perpendicular to the main runners, spaced 16 in. OC. Additional cross tees or cross channels used at 8 in. from each side of butted gypsum panel end joints. The cross tees or cross channels may be riveted or screw attached to the wall angle or channel to facilitate the ceiling installation.

c. **Cross Channels** — Nom 4 or 12 ft long, installed perpendicular to main runners, spaced 16 in. OC.

d. **Wall Angle or Channel** — Painted or galv steel angle with 1 in. legs or channel with 1 in. legs, 1-9/16 in. deep attached to walls at perimeter of ceiling with fasteners 16 in. OC. To support steel framing member ends and for screw-attachment of the gypsum panel.

CGC INC — Type DGL or RX

USG INTERIORS LLC — Type DGL or RX

8. **Gypsum Board*** — Nom 5/8 in. thick, 48 in. wide gypsum panels. When resilient channels (Item 7) are used, gypsum panels installed with long dimension perpendicular to resilient channels. Gypsum panels secured with 1 in. long Type S bugle-head screws spaced 8 in. OC in both the field and the perimeter, and 1-1/2 in. and 4 in. from side edges of the board. When Steel Framing Members (Item 7A) are used, gypsum panels installed with long dimension perpendicular to cross tees with side joints centered along main runners and end joints centered along cross tees. Panels fastened to cross tees with 1 in. long Type S bugle-head screws spaced 8 in. OC in the field and along end joints. Panels fastened to main runners with 1 in. long Type S bugle-head screws spaced midway between cross tees. Screws along sides and ends of panels spaced 3/8 to 1/2 in. from panel edge. End joints of panels shall be staggered with spacing between joints on adjacent panels not less than 4 ft OC.

CGC INC — Types C, IP-X2, IPC-AR

UNITED STATES GYPSUM CO — Types C, IP-X2, IPC-AR

USG BORAL DRYWALL SFZ LLC — Type C

USG MEXICO S A DE C V — Types C, IP-X2, IPC-AR

9. **Joint System** — Not Shown — Vinyl, dry or premixed joint compound, applied in two coats to joints and screw heads; paper tape, 2 in. wide, embedded in first layer of compound over all joints.

*** Indicates such products shall bear the UL or cUL Certification Mark for jurisdictions employing the UL or cUL Certification (such as Canada), respectively.**

Last Updated on 2018-10-23

The appearance of a company's name or product in this database does not in itself assure that products so identified have been manufactured under UL's Follow-Up Service. Only those products bearing the UL Mark should be considered to be Certified and covered under UL's Follow-Up Service. Always look for the Mark on the product.

UL permits the reproduction of the material contained in the Online Certification Directory subject to the following conditions: 1. The Guide Information, Assemblies, Constructions, Designs, Systems, and/or Certifications (files) must be presented in their entirety and in a non-misleading manner, without any manipulation of the data (or drawings). 2. The statement "Reprinted from the Online Certifications Directory with permission from UL" must appear adjacent to the extracted material. In addition, the reprinted material must include a copyright notice in the following format: "© 2020 UL LLC"