

XHBN.HW-D-0602 - Joint Systems

Design/System/Construction/Assembly Usage Disclaimer

- Authorities Having Jurisdiction should be consulted in all cases as to the particular requirements covering the installation and use of UL Certified products, equipment, system, devices, and materials.
- Authorities Having Jurisdiction should be consulted before construction.
- Fire resistance assemblies and products are developed by the design submitter and have been investigated by UL for compliance with applicable requirements. The published information cannot always address every construction nuance encountered in the field.
- When field issues arise, it is recommended the first contact for assistance be the technical service staff provided by the product manufacturer noted for the design. Users of fire resistance assemblies are advised to consult the general Guide Information for each product category and each group of assemblies. The Guide Information includes specifics concerning alternate materials and alternate methods of construction.
- Only products which bear UL's Mark are considered Certified.

XHBN - Joint Systems

See General Information for Joint Systems

System No. HW-D-0602

January 27, 2010

Assembly Ratings — 1 and 2 Hr (See Item 2)

L Rating at Ambient — Less Than 1 CFM/Lin ft

L Rating at 400° F — Less Than 1 CFM/Lin ft

Nominal Joint Width — 1 in.

Class II and III Movement Capabilities — 33% Compression or 66% Extension

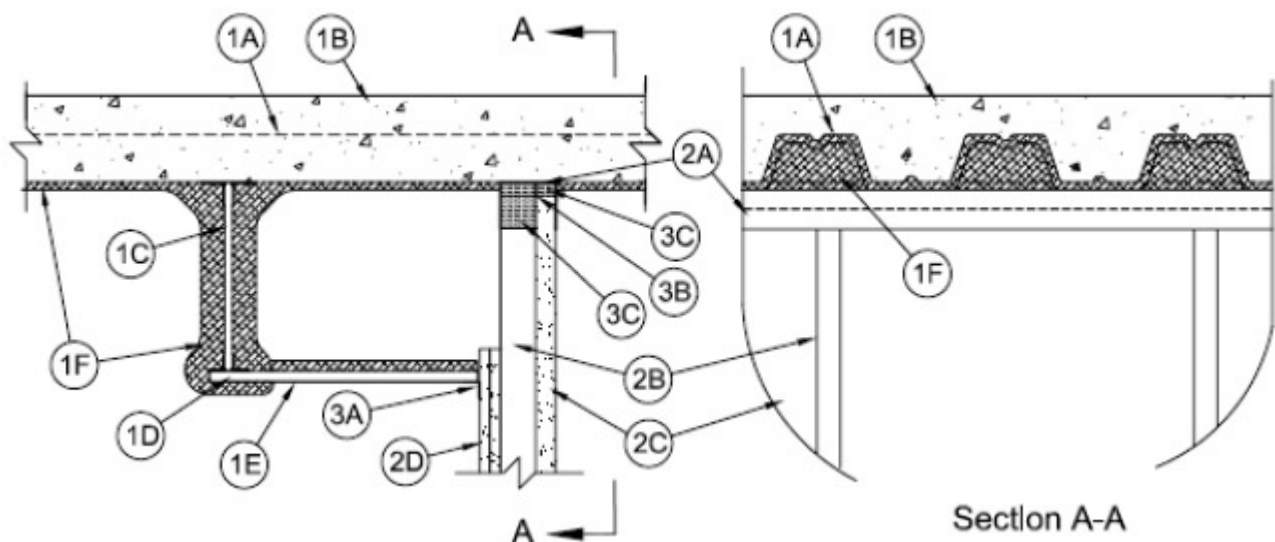

1. **Floor Assembly** — The fire-rated fluted steel deck/concrete floor assembly shall be constructed of the materials and in the manner described in the individual D700 Series Floor-Ceiling Design in the UL Fire Resistance Directory and shall include the following construction features:

A. **Steel Floor And Floor Units*** — Max 3 in. (76 mm) deep galv steel fluted floor units.

B. **Concrete** — Min 2-1/2 in. (64 mm) thick reinforced concrete, as measured from the top plane of the floor units.

C. **Structural Steel Support** — Steel beam, as specified in the individual D700 Series Floor-Ceiling Design, used to support steel floor units. Structural steel support oriented parallel to and 1 to 7 in. (25 to 178 mm) from wall assembly.

D. **Steel Attachment Clips** — Z-shaped clips formed from 1-1/2 in. (38 mm) wide strips of min 20 ga galv steel. Clips to be sized to extend through the thickness of the spray-applied fire-resistive material on the bottom flange of the steel beam with 1-1/2 in. (38 mm) long upper and lower legs. Legs of clips fastened to bottom of beam (prior to application of spray-applied fire-resistive materials) with steel fasteners or welds. Clips spaced max 16 in. (406 mm) OC and extend to within 1/4 to 3/4 in. (6 to 19 mm) from the surface of the wall.

E. **Steel Plate** — Min 22 ga. galv steel plate, sized to extend from beam to within 1/4 in. (6 mm) of wall surface. Plate is secured to bottom surface of each Z clip with min No. 8 steel sheet metal screws spaced a max 2in. (51 mm) from edges of plate and a max 4 in. (102 mm) OC.

F. **Spray-Applied Fire Resistive Material*** — After installation of the steel attachment clips, structural steel and ceiling runners, support to be sprayed with the min thickness of material specified in the individual D700 Series Design. The flutes of the steel floor units are to be filled with material across the entire top flange of the ceiling runner. The area on top of steel plate and in between Z clips is to be filled to the height of the Z clips plus an additional min 1 in. (25 mm) thickness.

ISOLATEK INTERNATIONAL — Type 300

GCP APPLIED TECHNOLOGIES INC — Type MK-6/HY

2. **Shaft Wall Assembly** — The 1 or 2 hr fire rated shaft wall assembly shall be constructed of the materials and in the manner described in the individual U400 or V400 Series Wall and Partition Design in the UL Fire Resistance Directory. The wall shall include the following construction features:

A. **Floor and Ceiling Runners** — "J"-shaped runner, min 2-1/2 in. (64 mm) wide with unequal legs of min 1-1/2 in. (32 mm) and 2 in. (52 mm), fabricated from min 24 MSG galv steel. Attached to steel deck with steel fasteners or welds spaced max 24 in. (610 mm) OC.

A1. **Light Gauge Framing* — Slotted Ceiling Track** — (Not Shown) - As an alternate to the "J"-shaped runner in Item 2A, a ceiling track consisting of galv steel channel with slotted flanges may be used. Slotted ceiling track sized to accommodate steel "C-T", "I" or "C-H" studs (Item 2C). Attached to steel deck with steel fasteners or welds spaced max 24 in. (610 mm) OC.

BRADY CONSTRUCTION INNOVATIONS INC, DBA SLIPTRACK SYSTEMS — SLP-TRK

CALIFORNIA EXPANDED METAL PRODUCTS CO — CST

CLARKDIETRICH BUILDING SYSTEMS — Type SLT, SLT-H

METAL-LITE INC — The System

SCAFCO STEEL STUD MANUFACTURING CO — Slotted Track

B. **Steel Studs** — "C-T", "I" or "C-H"-shaped steel studs to be min 2-1/2 in. (64 mm) wide and formed of min 24 MSG galv steel. Studs cut 1/2 to 3/4 in. (13 to 19 mm) less in length than assembly height with bottom nesting in and resting on floor runner and with top nesting in "J"-shaped runner or slotted ceiling track. Studs spaced max 24 in. (610 mm) OC. After installation of gypsum board liner panels (Item 2D), studs secured to flange of floor runner on finished side of wall only with No. 6 by 1/2 in. (13 mm) long self-drilling, self-tapping steel screws. If slotted ceiling track (Item 2A1) is used, studs secured to flange of slotted ceiling track on finished side of wall only with No. 8 by 1/2 in. (13 mm) long self-drilling, self-tapping wafer head steel screws at slot mid-height.

C. **Gypsum Board*** — 1 in. (25 mm) thick by max 24 in. (610 mm) wide gypsum board liner panels. Panels cut max 1/2 in. (13 mm) less in length than floor to ceiling height. Vertical edges inserted into "T"-shaped section of "C-T" studs, into holding tabs of "I" studs or into "H"-shaped section of "C-H" studs.

D. **Gypsum Board*** — Gypsum board, 1/2 or 5/8 in. (13 or 16 mm) thick, applied on finished side of wall as specified in the individual Wall and Partition Design. The boards to extend a min 3 in. (76 mm) above the bottom of Z clips. The screws attaching the gypsum board layer(s) to the "C-T", "I" or "C-H" studs shall be located a max of 2 in. (51 mm) below the bottom of the Z clips.

The hourly fire rating of the joint system is equal to the hourly fire rating of the wall.

3. **Joint System** — Max separation between spray-applied material on bottom of floor and top of wall (at time of installation of joint system) is 1 in. (25 mm). The joint system is designed to accommodate a max 33 percent compression or max 66% extension from its installed width.

A. **Fill, Void or Cavity Material*** — A nom 20 gauge steel angle provided with a nom 1 in. (25 mm) wide intumescent strip on one leg to be secured to the bottom leg of each z clip with the intumescent strip against the outer face of gypsum board on finished side of wall with min No. 8 steel sheet metal screws such that the intumescent strip is flat against the outer surface of the wall.

CALIFORNIA EXPANDED METAL PRODUCTS CO — Firestik FS1 or FS2

B. **Fill, Void or Cavity Material* - Sealant** — A min 1/8 in. (3 mm) wet thickness (min 1/16 in. or 1.6 mm dry thickness) of fill material applied on inside of stud cavity to completely cover mineral wool forming material and to overlap min 1/2 in. (13 mm) onto wall and top inside surface of slotted ceiling track (Item 2B) prior to installation of gypsum board sheets on finished side of wall.

SPECIFIED TECHNOLOGIES INC — SpecSeal ES Elastomeric Sealant., or SpecSeal AS200 Elastomeric Spray

C. **Forming Material*** — 1-1/2 in. (38 mm) thick by 1-1/2 in. (38 mm) wide sections of mineral wool batt insulation compressed 30 percent and installed cut edge first to fill the 1 in. (25 mm) gap between the top of gypsum board and bottom of the steel floor units. After the sealant (Item 3B) is applied an additional min 4-1/2 in. (114 mm) thick strips of min 4 pcf (64 kg/m³) mineral wool batt insulation cut to the width of the ceiling runner, compressed 33 percent in thickness and installed into ceiling runner between leg of track and gypsum liner board to completely fill cavity within ceiling runner.

*** Indicates such products shall bear the UL or cUL Certification Mark for jurisdictions employing the UL or cUL Certification (such as Canada), respectively.**

Last Updated on 2010-01-27

The appearance of a company's name or product in this database does not in itself assure that products so identified have been manufactured under UL's Follow-Up Service. Only those products bearing the UL Mark should be considered to be Certified and covered under UL's Follow-Up Service. Always look for the Mark on the product.

UL permits the reproduction of the material contained in the Online Certification Directory subject to the following conditions: 1. The Guide Information, Assemblies, Constructions, Designs, Systems, and/or Certifications (files) must be presented in their entirety and in a non-misleading manner, without any manipulation of the data (or drawings). 2. The statement "Reprinted from the Online Certifications Directory with permission from UL" must appear adjacent to the extracted material. In addition, the reprinted material must include a copyright notice in the following format: "© 2020 UL LLC"