

XHBN.HW-D-0550 - Joint Systems

Design/System/Construction/Assembly Usage Disclaimer

- Authorities Having Jurisdiction should be consulted in all cases as to the particular requirements covering the installation and use of UL Certified products, equipment, system, devices, and materials.
- Authorities Having Jurisdiction should be consulted before construction.
- Fire resistance assemblies and products are developed by the design submitter and have been investigated by UL for compliance with applicable requirements. The published information cannot always address every construction nuance encountered in the field.
- When field issues arise, it is recommended the first contact for assistance be the technical service staff provided by the product manufacturer noted for the design. Users of fire resistance assemblies are advised to consult the general Guide Information for each product category and each group of assemblies. The Guide Information includes specifics concerning alternate materials and alternate methods of construction.
- Only products which bear UL's Mark are considered Certified.

XHBN - Joint Systems XHBN7 - Joint Systems Certified for Canada

See General Information for Joint Systems

See General Information for Joint Systems Certified for Canada

System No. HW-D-0550

February 18, 2020

ANSI/UL2079	CAN/ULC S115
Assembly Ratings — 1 and 2 Hr (See Item 2)	F Ratings — 1 and 2 Hr (See Item 2)
Nominal Joint Width — 3/8, 1/2, 5/8, 3/4, 1, 1-1/2 In. (See Item 3)	FT Ratings — 1 and 2 Hr (See Item 2)
Class II or III Movement Capabilities — 80% Compression or Extension or 33% Compression or Extension (See Item 3) Class II Movement Capabilities — 75% Compression, 25% Extension (See Item 3A)	FH Ratings — 1 and 2 Hr (See Item 2)
L Rating at Ambient — Less than 1 CFM/Lin Ft	FTH Ratings — 1 and 2 Hr (See Item 2)
L Rating at 400°F — Less than 1 CFM/Lin Ft	Nominal Joint Width — 10, 13, 16, 19, 25, 38 mm. (see Item 3)
	Class II or III Movement Capabilities — 80% Compression or Extension or 33% Compression or Extension (See Item 3) Class II Movement Capabilities — 75% Compression, 25% Extension (See Item 3A)
	L Rating at Ambient — Less than 1 CFM/Lin Ft

L Rating at 400°F — Less than 1 CFM/Lin Ft
--

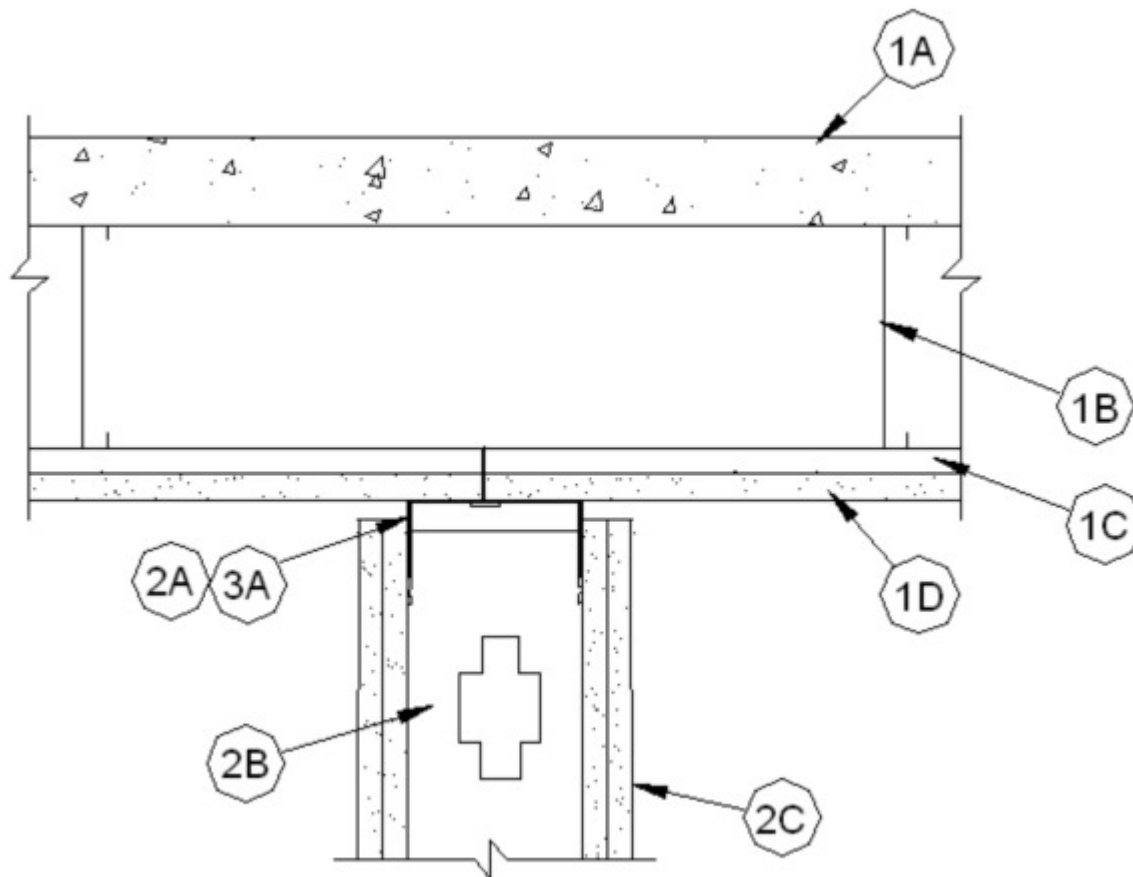

1. **Floor-Ceiling Assembly** — The 1 or 2 hr fire rated concrete and steel joist Floor-Ceiling assembly shall be constructed of the materials and in the manner described in the individual G500 Series Design in the UL Fire Resistance Directory, as summarized below:

A. **Flooring** — Lightweight or normal weight (100-150 pcf or 1600-2400 kg/m³) concrete as specified in the individual G500 Series Design.

B. **Joists** — Steel joists or **Structural Steel Members*** as specified in the individual G500 Series Design.

C. **Furring Channels** — Steel furring channels as specified in the individual G500 Series Design, spaced max 16 in. (406 mm) OC.

D. **Gypsum Board*** — Min 5/8 in. (16 mm) thick, screw-attached to furring channels as specified in the individual G500 Series Design.

The hourly rating of the joint system is equal to the lesser of the hourly ratings of the floor-ceiling assembly and the wall assembly.

2. **Wall Assembly** — The 1 or 2 hr fire rated gypsum board/stud wall assembly shall be constructed of the materials and in the manner described in the individual U400 or V400 Series Wall and Partition Design in the UL Fire Resistance Directory and shall include the following construction features:

A. **Steel Floor and Ceiling Runners** — Floor runners of wall assembly shall consist of min No. 25 gauge galv steel channels sized to accommodate steel studs (Item 2B). Floor runner to be provided with min 1-1/4 in. (32 mm) flanges. The ceiling runners are provided with a fill, void or cavity material and are described in Item 3A. Ceiling runner installed perpendicular to furring channels (Item 1C) and secured to each furring channel through gypsum board (Item 1D) with steel fasteners specified in the individual G500 series design for the attachment of the gypsum board to the furring channels.

A1. Light Gauge Framing* — Slotted Ceiling Track — (Not Shown) — As an alternate to the Item 2A, a ceiling track consisting of galv steel channel with slotted flanges may be used when Item 3A.1 fill material is utilized. Slotted ceiling track sized to accommodate steel studs (Item 2B). Legs are to be min 1/4 in. (6 mm) longer than the maximum joint width. Attached to steel deck with steel fasteners or welds spaced max 24 in. (610 mm) OC.

BRADY CONSTRUCTION INNOVATIONS INC, DBA SLIPTRACK SYSTEMS — SLP-TRK

CALIFORNIA EXPANDED METAL PRODUCTS CO — CST, CST 325

MARINO/WARE, DIV OF WARE INDUSTRIES INC — Type SLT

B. Studs — Steel studs to be min 3-5/8 in. (92 mm) wide. Studs cut 5/8 in. to 1-1/4 in. (16 to 32 mm) less in length than assembly height with bottom nesting in and secured to floor runner. Steel studs nested in non-slotted ceiling runner without attachment or secured to slotted ceiling runner with No. 8 by 1/2 in. (13 mm) long wafer head steel screws at mid-height of slot.

B1. Framing Members - Steel Studs* — In lieu of Item B - Proprietary channel shaped studs, 3-5/8 in. wide spaced a max of 24 in. OC. Studs to be cut 5/8 to 1-1/4 in (16 to 32 mm) less than the assembly height with bottom nesting in and secured to floor runner. Steel studs nested in non-slotted ceiling runner without attachment or secured to slotted ceiling runner with No. 8 by 1/2 in. (13 mm) long wafer head steel screws at mid-height of exposed slot.

CALIFORNIA EXPANDED METAL PRODUCTS CO — ViperStud™

MARINO/WARE, DIV OF WARE INDUSTRIES INC — ViperStud™

C. Gypsum Board* — Gypsum board sheets installed to a min total 5/8 in. (16 mm) or 1-1/4 in. (32 mm) thickness on each side of wall for 1 and 2 hr fire rated assemblies, respectively. Wall to be constructed as specified in the individual U400 or V400 Series Design in the UL Fire Resistance Directory except that a max 1/2 in. (13 mm) gap shall be maintained between the top of the gypsum board and the bottom of the floor-ceiling assembly. The screws attaching the gypsum board to the studs along the top of the wall shall be located 4 to 5 in. (102 to 127 mm) below the bottom of the ceiling assembly. No gypsum board attachment screws shall be driven into the ceiling runner.

The hourly rating of the joint system is equal to the lesser of the hourly ratings of the floor-ceiling assembly and the wall assembly.

3. Joint System — Max separation between bottom of floor and top of wall (at time of installation of joint system) is 1/2 in. (13 mm) or 3/8 in. if Item 3A1 is utilized. The joint system is designed to accommodate a max 80 percent compression and or 30 percent extension from its installed width. When Item 3A2, 3A3 or 3A4 is used, the maximum installed joint width is 3/4 in. (19 mm) and the movement is max 80% compression and 33% extension. When 3A3 is used to fill nominal gap, the maximum installed width is 1/2 in. (13mm) and movement is 75% compression and 25% extension. When Item 3A5 is used the joint will accommodate 50 percent compression only.

A. Fill, Void or Cavity Material* — Min 25 ga composite steel angle with one 5/8 in. (16 mm) leg and one 1-1/4 in (32 mm) leg with a strip of intumescent strip affixed along the inside 1-1/4 in (32 mm) leg. Steel angle is friction fit between the top web of the ceiling runner and the concrete deck.

CALIFORNIA EXPANDED METAL PRODUCTS CO — DDA-1 (Deflection Drift Angle)

A1. Fill, Void or Cavity Material* — For 3/8 in (10mm) gap Min 20 ga steel channel track with 2, or 2-3/4 in. (51, or 70 mm) legs with or without slots having nom 1/2 in. (13 mm) wide intumescent strips affixed to the top web along the outer corner on both sides and sized to accommodate steel studs. Track attached to concrete deck with steel fasteners or welds spaced max 24 in. (610 mm) OC.

CALIFORNIA EXPANDED METAL PRODUCTS CO — FAS Track 1000, FAS Track 1000DL

MARINO/WARE, DIV OF WARE INDUSTRIES INC — FAS Track 1000, FAS Track 1000DL

A2. Fill, Void or Cavity Material* — (Not Shown) — As an alternate to 3A, 3A1, 3A2 Nom. 1 in. (25.4 mm) open cell foam plug having a nom 5/16 in. (8 mm) intumescent tape applied to the top surface of the foam profile. The foam is sized for 1 or 2 hour walls and shall be placed in the joint above the top edge of the drywall between the floor/ceiling assembly. A layer of tape and joint compound shall then be applied over the hot rod assembly.

CALIFORNIA EXPANDED METAL PRODUCTS CO — HOT ROD Type-X

MARINO/WARE, DIV OF WARE INDUSTRIES INC — HOT ROD Type-X

A3. Fill, Void or Cavity Material* — (Not Shown) — As an alternate to 3A, 3A1, 3A2. For 1/2 in. (13 mm) gap, Nom., 1 in. (25.4 mm) open cell foam plug having a nom 5/16 in. (8 mm) intumescent tape applied to the top surface of the foam profile. The foam is sized for 1 or 2 hour walls and shall be placed in the joint above the top edge of the drywall between the floor/ceiling assembly.

CALIFORNIA EXPANDED METAL PRODUCTS CO — HOT ROD Type-X

MARINO/WARE, DIV OF WARE INDUSTRIES INC — HOT ROD Type-X

A4. Fill, Void or Cavity Material* — (Not Shown) — As an alternate to HOTROD (3A2 and 3A3) for 3/4 (19 mm) gap between the edge of the drywall and the floor/ceiling assembly shall be filled with vinyl deflection bead with 5/16 in. (8 mm) intumescent strip and foam applied to horizontal leg that runs above the edge of the drywall. The perforated leg may be attached to surface of drywall with 1/2 in. (13 mm) staples every 6-8 in. (152-203 mm).

CALIFORNIA EXPANDED METAL PRODUCTS CO — HOTROD TYPE XL

MARINO/WARE, DIV OF WARE INDUSTRIES INC — HOT ROD Type-XL

TRIM-TEX INC — Trim Tex-Hot Rod Type XL

A5. Fill, Void or Cavity Material* — (Not Shown) - As an alternate to HOTROD (Item 3A3) at the 1/2 in. gap between the edge of the drywall and the floor/ceiling assembly shall be filled with vinyl deflection bead with 5/16 in. intumescent strip applied to horizontal leg that runs above the edge of the drywall. The horizontal leg is sized at 5/8 in. for 1-hour walls and 1-1/4 in. for 2-hour walls. Joint compound may be applied over perforated flange and drywall.

CALIFORNIA EXPANDED METAL PRODUCTS CO — FIRE BEAD (Fire Rated Deflection Bead)

MARINO/WARE, DIV OF WARE INDUSTRIES INC — FIRE BEAD

TRIM-TEX INC — Trim Tex-Fire Bead (Fire Rated Deflection Bead)

A6. Fill, Void or Cavity Material* — (Not Shown) - For nominal 1/2 in. (12mm) gaps 100% compression/ extension or 1 in. (25mm) compression only. As an alternate to DDA-1 (Item A) a composite corrugated vinyl profile with a 1-1/2 in. (38 mm) wide leg and a 3/8 in. (10 mm) bubble gasket along the upper edge. A 5/8 in. (16 mm) wide intumescent strip affixed along the inside 1-1/2 in. (38 mm) leg. Composite vinyl profile is attached to the leg of the ceiling runner/track with 1/2 in. (13 mm) No. 8 framing screws or adhesively attached with double sided foam tape.

CALIFORNIA EXPANDED METAL PRODUCTS CO — Fire Gasket 1

MARINO/WARE, DIV OF WARE INDUSTRIES INC — Fire Gasket 1

TRIM-TEX INC — Trim Tex-Fire Gasket 1

A7. **Fill, Void or Cavity Material*** — (Not Shown) - For nominal 3/4 in. (19mm) gaps 100% compression/extension or 1-1/2 in. (38mm) compression only. As an alternate to DDA-1 (Item A) a composite corrugated vinyl profile with a 2 in. (50 mm) wide leg and a 3/8 in. (10 mm) bubble gasket along the upper edge. A 1 in. (25 mm) wide intumescent strip affixed along the inside 1-1/2 in. (38 mm) leg. Composite vinyl profile is attached to the leg of the ceiling runner/track with 1/2 in. (13 mm) No. 8 framing screws or adhesively attached with double sided foam tape.

CALIFORNIA EXPANDED METAL PRODUCTS CO — Fire Gasket 1.5

MARINO/WARE, DIV OF WARE INDUSTRIES INC — Fire Gasket 1.5

TRIM-TEX INC — Trim Tex-Fire Gasket 1.5

B. **Packing Material** — (Not Shown) - Required for use with Items 3A and 3A1 are used.) A continuous length of open cell polyurethane foam with a nominal diameter of 1/8 in. (3.2 mm) greater than the max width of the joint. The foam shall have a nominal density of 1.7 pcf. The foam is to be placed in the joint above the top edge of the drywall between the ceiling assembly. Any splices are to be tightly butted. A layer of tape and joint compound can then be applied over the open cell foam.

*** Indicates such products shall bear the UL or cUL Certification Mark for jurisdictions employing the UL or cUL Certification (such as Canada), respectively.**

Last Updated on 2020-02-18

The appearance of a company's name or product in this database does not in itself assure that products so identified have been manufactured under UL's Follow-Up Service. Only those products bearing the UL Mark should be considered to be Certified and covered under UL's Follow-Up Service. Always look for the Mark on the product.

UL permits the reproduction of the material contained in the Online Certification Directory subject to the following conditions: 1. The Guide Information, Assemblies, Constructions, Designs, Systems, and/or Certifications (files) must be presented in their entirety and in a non-misleading manner, without any manipulation of the data (or drawings). 2. The statement "Reprinted from the Online Certifications Directory with permission from UL" must appear adjacent to the extracted material. In addition, the reprinted material must include a copyright notice in the following format: "© 2020 UL LLC"