

# XHBN.HW-D-0548 - Joint Systems

## Design/System/Construction/Assembly Usage Disclaimer

- Authorities Having Jurisdiction should be consulted in all cases as to the particular requirements covering the installation and use of UL Certified products, equipment, system, devices, and materials.
- Authorities Having Jurisdiction should be consulted before construction.
- Fire resistance assemblies and products are developed by the design submitter and have been investigated by UL for compliance with applicable requirements. The published information cannot always address every construction nuance encountered in the field.
- When field issues arise, it is recommended the first contact for assistance be the technical service staff provided by the product manufacturer noted for the design. Users of fire resistance assemblies are advised to consult the general Guide Information for each product category and each group of assemblies. The Guide Information includes specifics concerning alternate materials and alternate methods of construction.
- Only products which bear UL's Mark are considered Certified.

## XHBN - Joint Systems XHBN7 - Joint Systems Certified for Canada

See General Information for Joint Systems

See General Information for Joint Systems Certified for Canada

### System No. HW-D-0548

March 16, 2020

ANSI/UL2079	CAN/ULC S115
Assembly Ratings — 1 and 2 Hr (See Item 2)	F Ratings — 1 and 2 Hr (See Item 2)
Maximum Joint Width — 3/4, 1 or 1-1/2 In. (See Item 3)	FT Ratings — 1 and 2 Hr (See Item 2)
Class II Movement Capabilities — 50 or 100 %Compression or Extension (See Item 3)	FH Ratings — 1 and 2 Hr (See Item 2)
L Rating At Ambient — Less Than 1 CFM/sq ft	FTH Ratings — 1 and 2 Hr (See Item 2)
L Rating At 400 F — Less Than 1 CFM/sq ft	Maximum Joint Width — 19, 25 or 38 mm (See Item 3)
	Class II Movement Capabilities — 50 or 100 % Compression or Extension (See Item 3)
	L Rating At Ambient — Less Than 1 CFM/sq ft
	L Rating At 400 F — Less Than 1 CFM/sq ft

# CONFIGURATION A

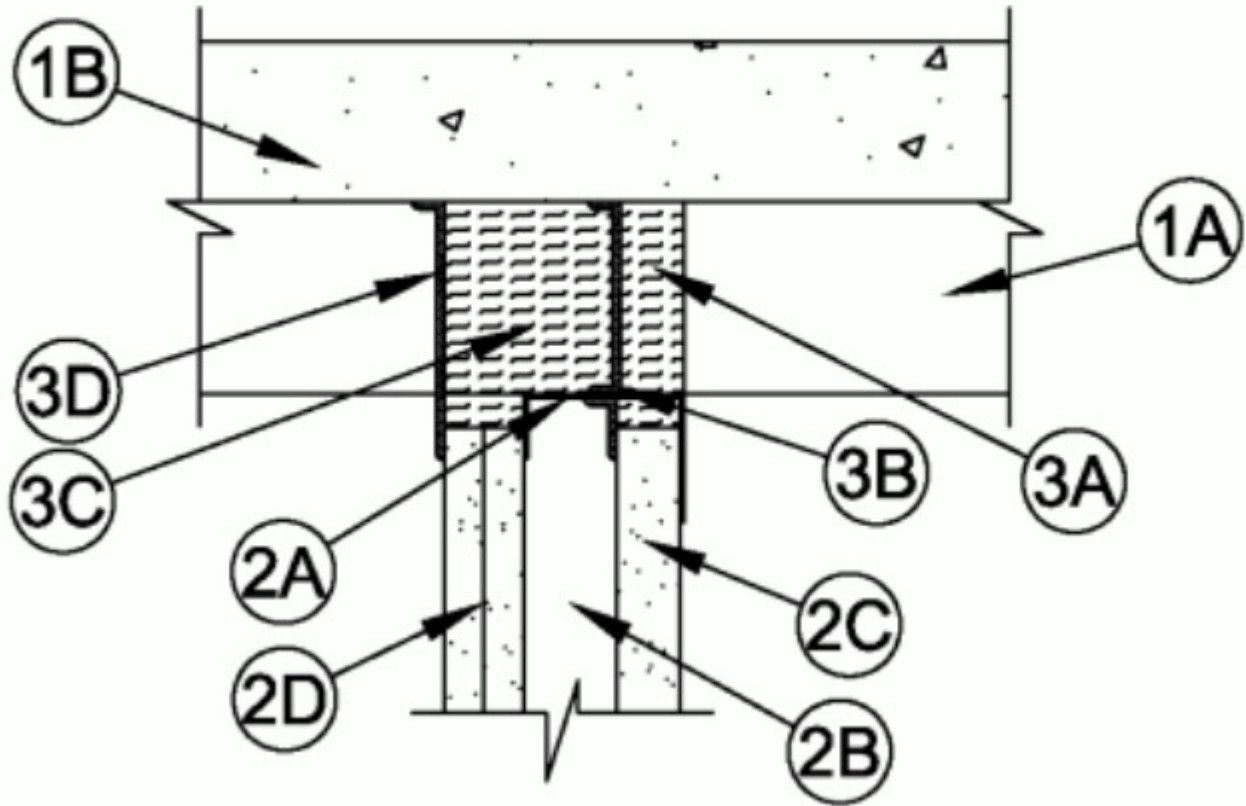

# CONFIGURATION B

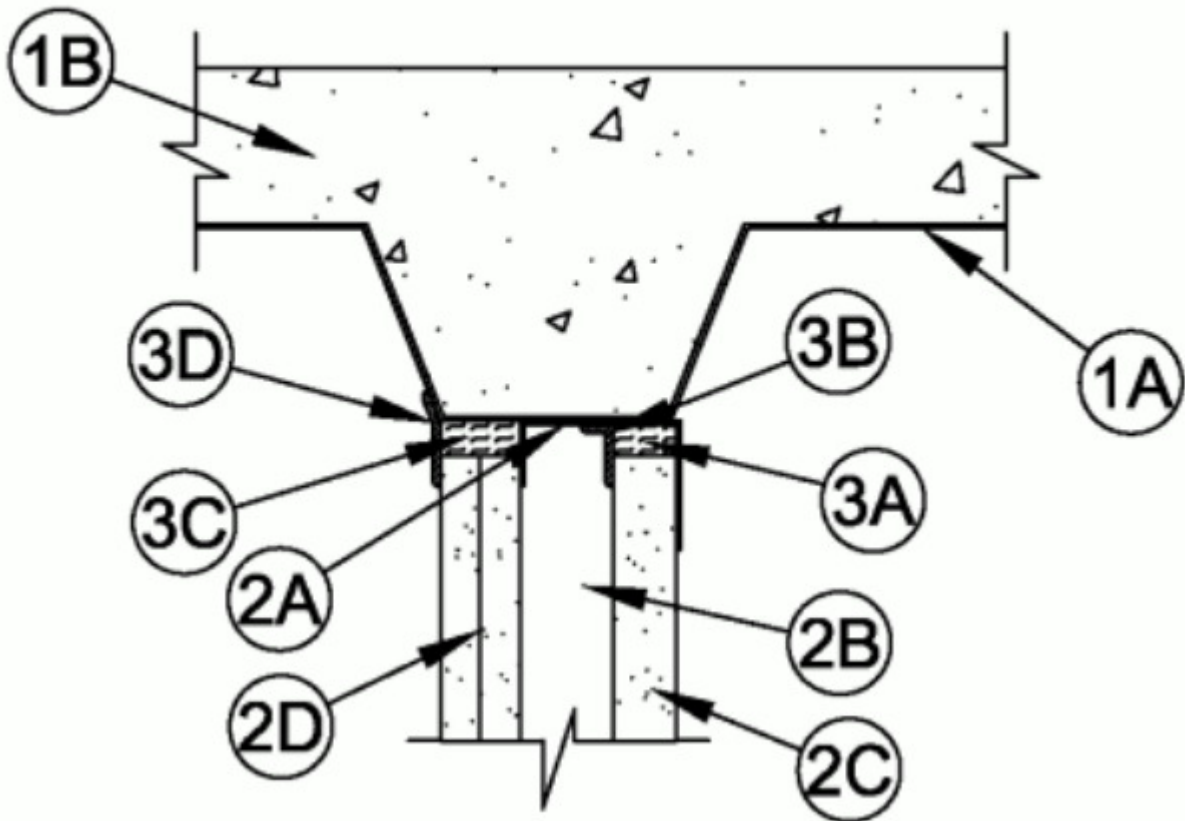

# CONFIGURATION C

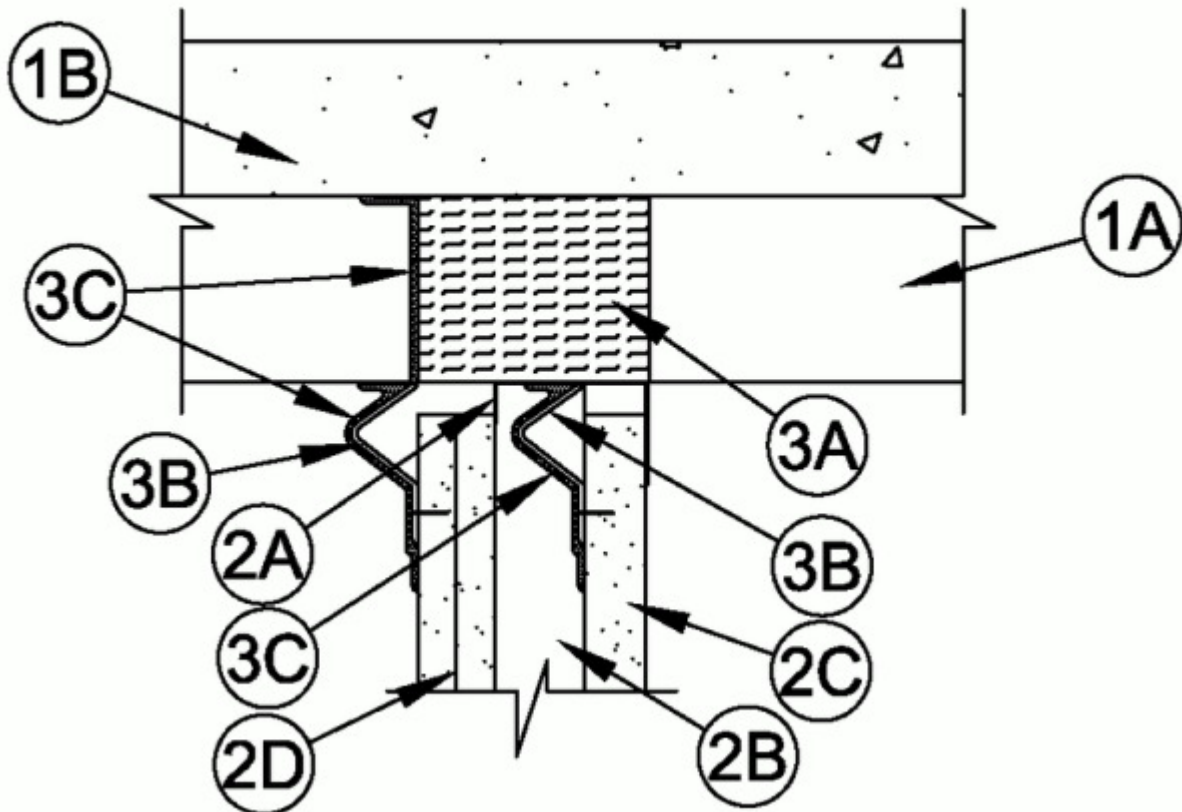

**1. Floor Assembly** — The fire-rated fluted steel deck/concrete floor assembly shall be constructed of the materials and in the manner described in the individual D900 Series Floor-Ceiling Design in the UL Fire Resistance Directory. The hourly fire rating of the floor assembly shall be equal to or greater than the hourly fire rating of the wall assembly. The floor assembly shall include the following construction features:

A. **Steel Floor and Form Units\*** — Max 3 in. (76 mm) deep galv steel fluted floor units.

B. **Concrete** — Min 2-1/2 in. (64 mm) thick reinforced concrete, as measured from the top plane of the floor units.

**1A. Roof Assembly** — (Not Shown) - As an alternate to the floor assembly (Item 1), a fire rated fluted steel deck roof assembly may be used. The roof assembly shall be constructed of the materials and in the manner described in the individual P900 Series Roof-Ceiling Design in the UL Fire Resistance Directory. The hourly fire rating of the roof assembly shall be equal to or greater than the hourly fire rating of the wall assembly. The roof assembly shall include the following construction features:

A. **Steel Roof Deck** — Max 3 in. (76 mm) deep galv steel fluted roof deck.

B. **Roof Insulation** — Min 2-1/4 in. (57 mm) thick poured insulating concrete, as measured from the top plane of the steel roof deck.

**1B. Floor Assembly** — As an alternate to the floor assembly (Item 1), min 4-1/2 in. (114 mm) thick reinforced lightweight or normal weight (100-150 pcf or 1600-2400 kg/m<sup>3</sup>) structural concrete. Floor may also be constructed of any UL Classified hollow-core **Precast Concrete Units\***.

See **Precast Concrete Units** (CFTV) in Fire Resistance Directory for names of manufacturers.

**2. Shaft Wall Assembly** — The 1 or 2 hr fire rated shaft wall assembly shall be constructed of the materials and in the manner described in the individual U400, V400 or W400 Series Wall and Partition Design in the UL Fire Resistance Directory and shall include the following construction features:

A. **Floor and Ceiling Runners** — "J"-shaped runner, min 2-1/2 in. (64 mm) wide with unequal legs of min 1-1/2 in. (38 mm) and min 2 in. (51 mm), fabricated from min 24 MSG galv steel. Runners positioned with short leg toward finished side of wall. Flange height of ceiling runner shall be min 1/4 in. (6 mm) greater than max extended joint width. Runners

attached to walls and floor with steel fasteners spaced max 24 in. (610 mm) OC. As an alternate to the "J"-shaped runner, a min 2-1/2 in. (64 mm) wide by 1 in. or 1 1/4 in. (25 or 32 mm) deep channel formed from min 24 MSG galv steel may be used for the floor runner. Ceiling runner installed parallel with or perpendicular to direction of fluted steel deck and secured to steel deck valley with steel fasteners or welds spaced max 24 in. (610 mm) OC.

**A1. Floor And Ceiling Runners** — As an alternate to Item 2A, floor and ceiling runners of wall assembly shall consist of galv steel channels sized to accommodate steel "C-H" studs. Flange height of ceiling runner shall be min 1/2 in. (13 mm) greater than nom joint width. Ceiling runner installed parallel with or perpendicular to direction of fluted steel deck and secured with steel masonry anchors or welds spaced max 24 in. (610 mm) OC.

**A2. Light Gauge Framing\* - Slotted Ceiling Track — (for use in Configuration A Only)** As an alternate to Item 2A, slotted ceiling track shall consist of galv steel channels with slotted flanges. Slotted ceiling track sized to accommodate steel "C-H" studs (Item 2C). Attached to concrete at ceiling with steel fasteners spaced max 12 in. OC (305 mm).

**BRADY CONSTRUCTION INNOVATIONS INC, DBA SLIPTRACK SYSTEMS** — SLP-TRK, SLPTRK325

**CALIFORNIA EXPANDED METAL PRODUCTS CO** — ST, CST325

**CLARKDIETRICH BUILDING SYSTEMS** — Type SLT, SLT-H

**MARINO/WARE, DIV OF WARE INDUSTRIES INC** — Type SLT

**RAM SALES L L C** — RAM Slotted Track

**SCAFCO STEEL STUD MANUFACTURING CO**

**TELLING INDUSTRIES L L C** — True-Action Deflection Track

**A3. Light Gauge Framing\* - Slotted Ceiling Runner** — As an alternate to the ceiling runner in Items 2A through 2A3, slotted ceiling runner to consist of galv steel channel with 3-1/4 in. (83 mm) high slotted flanges sized to accommodate steel studs (Item 2B). Ceiling runner installed parallel or perpendicular with direction of fluted steel deck and secured to steel deck valley with steel fasteners or welds spaced max 24 in. (610 mm) OC.

**BRADY CONSTRUCTION INNOVATIONS INC, DBA SLIPTRACK SYSTEMS** — SLPTRK325

**B. Steel Studs** — "C-H"-shaped steel studs to be min 2-1/2 in. (64 mm) wide and formed of min 24 MSG galv steel. For configuration A studs cut 1/2 to 1-1/4 in. (13 to 32 mm) less in length than assembly height or for configuration B studs cut 1 to 1-1/2 in. (25 to 38 mm) less in length than assembly height with bottom nesting in and resting on floor runner and with top nesting in ceiling runner or slotted ceiling track. Studs spaced 24 in. (610 mm) OC. After installation of gypsum board liner panels (Item 2D), studs secured to flange of floor runner on finished side of wall with No. 6 by 1/2 in. (13 mm) long self-drilling, self-tapping steel screws. Studs secured to flange of slotted ceiling track on finished side of wall only with No. 8 by 1/2 in. (13 mm) long self-drilling, self-tapping wafer head steel screws at slot midheight.

**C. Gypsum Board\*** — 1 in. (25 mm) thick by 24 in. (610 mm) wide gypsum board liner panels. Panels cut 1 in. (25 mm) less in length than floor to ceiling height. Vertical edges inserted in "H"-shaped section of "C-H" studs. Free edge of end panels attached to long leg of "J" runner (Item 2A) with 1-5/8 in. (41 mm) long Type S steel screws spaced max 12 in. (305 mm) OC.

**D. Gypsum Board\*** — Gypsum board sheets, 1/2 or 5/8 in. (13 or 16 mm) thick, applied vertically or horizontally in one or two layers on finished side of wall as specified in the individual U400 or V400-Series Wall and Partition Design. A max 1 in. (25 mm) gap shall be maintained between the top of the gypsum board and the bottom surface of the concrete floor. The screws attaching the gypsum board layers to the C-H studs shall be located 1 in. (25 mm) below the

bottom of the slotted ceiling track (Item 2C). No gypsum board attachment screws are to penetrate the slotted ceiling track.

**The hourly fire rating of the joint system is equal to the hourly fire rating of the wall.**

## Configuration A

**3. Joint System — Max separation between bottom of floor and top of liner panel (Item 2C) and between bottom of floor and top of gypsum board sheets (Item 2D) at time of installation of joint system 1-1/2 in. (38 mm). The joint system is designed to accommodate a maximum 50 percent compression or extension from its installed width.** The joint system consists of forming material and sealant, as follows:

**A. Forming Material\*** — In floor or roof assembly constructed with steel fluted floor units, compression-fit a minimum 1 in. (25 mm) depth of nom 4 pcf (64 kg/m<sup>3</sup>) mineral wool batt insulation into far recess of flute valley as a permanent form. Strips of mineral wool batt insulation cut to width of gypsum liner panel (Item 2C) and compressed 50 percent in thickness. Strip installed between top of gypsum liner panel and bottom of steel ceiling runner.

**INDUSTRIAL INSULATION GROUP L L C** — MinWool 1200 Safing

**JOHNS MANVILLE** — Safing

**ROCK WOOL MANUFACTURING CO** — Delta Board

**ROCKWOOL MALAYSIA SDN BHD** — SAFE

**ROCKWOOL** — SAFE

**THERMAFIBER INC** — SAF

**B. Fill, Void or Cavity Material\*- Sealant** — Min 1/8 in. (3.2 mm) wet thickness (min 1/16 in. or 1.5 mm dry thickness) of spray applied to cover mineral wool batt insulation within joint cavity (when present; Item 3A) and mineral wool batt installed above gypsum liner panel (Item 2C). Maintain min 1/2 in. (13 mm) overlaps onto surrounding substrates.

**SPECIFIED TECHNOLOGIES INC** — SpecSeal AS200 Elastomeric Spray

**C. Forming Material\*** — Sections of min 4 pcf (64kg/m<sup>3</sup>) density mineral wool batt insulation cut to fill flute area (when present) flush with interior surface of wall after installation of spray (Item 3B). Strips of mineral wool batt insulation cut to width of gypsum board layers (Item 2D) and compressed 50 percent in thickness. Strips installed above gypsum board layers on finished side of wall assembly flush with the wall surface.

**INDUSTRIAL INSULATION GROUP L L C** — MinWool 1200 Safing

**JOHNS MANVILLE** — Safing

**ROCK WOOL MANUFACTURING CO** — Delta Board

**ROCKWOOL MALAYSIA SDN BHD** — SAFE

**ROCKWOOL** — SAFE

**THERMAFIBER INC** — SAF

D. **Fill, Void or Cavity Material\*- Sealant** — Min 1/8 in. (3.2 mm) wet thickness (min 1/16 in. or 1.5 mm dry thickness) of spray applied to cover mineral wool batt insulation on finished side of wall. Maintain min 1/2 in. (13 mm) overlaps onto surrounding substrates.

**SPECIFIED TECHNOLOGIES INC** — SpecSeal AS200 Elastomeric Spray

## Configuration B

3. **Joint System** — Max separation between bottom of floor and top of liner panel (Item 2C) and between bottom of floor and top of gypsum board sheets (Item 2D) at time of installation of joint system is 1-1/2 in. (38 mm). The joint system is designed to accommodate a maximum 50 percent compression or extension from its installed width. The joint system consists of forming material and sealant, as follows:

A. **Forming Material\*** — Strips of min 4 pcf (64kg/m<sup>3</sup>) density mineral wool batt insulation cut to width of gypsum liner panel (Item 2C) and compressed 50 percent in thickness. Strip installed between top of gypsum liner panel and bottom of steel ceiling runner.

**INDUSTRIAL INSULATION GROUP L L C** — MinWool 1200 Safing

**JOHNS MANVILLE** — Safing

**ROCK WOOL MANUFACTURING CO** — Delta Board

**ROCKWOOL MALAYSIA SDN BHD** — SAFE

**ROCKWOOL** — SAFE

**THERMAFIBER INC** — SAF

B. **Fill, Void or Cavity Material\*- Sealant** — Min 1/8 in. (3.2 mm) wet thickness (min 1/16 in. or 1.5 mm dry thickness) of spray applied to cover mineral wool batt insulation within joint cavity. Maintain min 1/2 in. (13 mm) overlaps onto surrounding substrates.

**SPECIFIED TECHNOLOGIES INC** — SpecSeal AS200 Elastomeric Spray

C. **Forming Material\*** — Strips of min 4 pcf (64kg/m<sup>3</sup>) density mineral wool batt insulation cut to width of gypsum board layers (Item 2D) and compressed 50 percent in thickness. Strips installed above gypsum board layers on finished side of wall assembly flush with the wall surface.

**INDUSTRIAL INSULATION GROUP L L C** — MinWool 1200 Safing

**JOHNS MANVILLE** — Safing

**ROCK WOOL MANUFACTURING CO** — Delta Board

**ROCKWOOL MALAYSIA SDN BHD** — SAFE

**ROCKWOOL** — SAFE

**THERMAFIBER INC** — SAF

**D. Fill, Void or Cavity Material\*- Sealant** — Min 1/8 in. (3.2 mm) wet thickness (min 1/16 in. or 1.5 mm dry thickness) of spray applied to cover mineral wool batt insulation on finished side of wall. Maintain min 1/2 in. (13 mm) overlaps onto surrounding substrates.

**SPECIFIED TECHNOLOGIES INC** — SpecSeal AS200 Elastomeric Spray

## Configuration C

**3. Joint System — Max separation between bottom of floor and top of liner panel (Item 2C) and between bottom of floor and top of gypsum board sheets (Item 2D) at time of installation of joint system is 3/4 or 1 in. (19 or 25 mm).**

**The joint system is designed to accommodate a maximum 100 percent compression or extension for 3/4 in. (19 mm) wide joints and a maximum 100 percent compression only for 1 in. (25 mm) wide joints, from its installed width.** The joint system consists of the following:

The joint system consists of the following:

**A. Forming Material\*** — Nom 3/16 in. (4.8 mm) thick by 4 in. (102 mm) high joint forming material profile installed on both sides of the wall assembly. Profile installed on the shaft side of the wall by first marking a line across the top of the wall 3 in. (76 mm) below the bottom plane of the bottom of the "J" or ceiling runner on the interior surface of the gypsum liner. Joint profile material on shaft side positioned with its top edge against both the underside of the ceiling runner with its bottom edge on the line scribed on the shaft liner. Profile installed on the finished side of the wall by first marking a line across the top of the wall 3 in. (76 mm) below the bottom plane of the steel floor or roof deck valleys. Joint profile material on finished side positioned with its top edge against both the underside of the floor or steel deck with its bottom edge on the line scribed on the finished side of the wall assembly. Bottom of the joint profile attached to gypsum board with nom 1/2 in. (13 mm) long steel staples spaced not greater than 8 in. (203 mm) OC. Adjoining lengths of profile to overlap approx 3/4 in. (19 mm) at shiplapped ends.

**SPECIFIED TECHNOLOGIES INC** — SpecSeal Speed Flex Joint Profile

**B. Fill, Void or Cavity Material\*- Sealant** — Min 1/8 in. (3.2 mm) wet thickness (min 1/16 in. or 1.5 mm dry thickness) of spray applied to cover forming material within joint cavity (Item 3A) and forming material installed above gypsum liner panel (Item 2D). Maintain min 1/2 in. (13 mm) overlaps onto surrounding substrates.

**SPECIFIED TECHNOLOGIES INC** — SpecSeal AS200 Elastomeric Spray

**C. Forming Material\*** — Sections of min 4 pcf (64kg/m<sup>3</sup>) density mineral wool batt insulation cut to fill flute area (when present) flush with interior surface of wall after installation of spray (Item 3B). Strips of mineral wool batt insulation cut to width of gypsum board layers (Item 2E) and compressed 50 percent in thickness. Strips installed above gypsum board layers on finished side of wall assembly flush with the wall surface.

**INDUSTRIAL INSULATION GROUP L L C** — MinWool 1200 Safing

**ROCK WOOL MANUFACTURING CO** — Delta Board

**ROCKWOOL MALAYSIA SDN BHD** — SAFE

**ROCKWOOL** — SAFE

**THERMAFIBER INC** — SAF

**D. Fill, Void or Cavity Material\*- Sealant** — Min 1/8 in. (3.2 mm) wet thickness (min 1/16 in. or 1.5 mm dry thickness) of spray applied to cover forming material (Item 3C) on finished side of wall. Maintain min 1/2 in. (13 mm) overlaps onto surrounding substrates.

**SPECIFIED TECHNOLOGIES INC** — SpecSeal AS200 Elastomeric Spray

**\* Indicates such products shall bear the UL or cUL Certification Mark for jurisdictions employing the UL or cUL Certification (such as Canada), respectively.**

Last Updated on 2020-03-16

---

The appearance of a company's name or product in this database does not in itself assure that products so identified have been manufactured under UL's Follow-Up Service. Only those products bearing the UL Mark should be considered to be Certified and covered under UL's Follow-Up Service. Always look for the Mark on the product.

UL permits the reproduction of the material contained in the Online Certification Directory subject to the following conditions: 1. The Guide Information, Assemblies, Constructions, Designs, Systems, and/or Certifications (files) must be presented in their entirety and in a non-misleading manner, without any manipulation of the data (or drawings). 2. The statement "Reprinted from the Online Certifications Directory with permission from UL" must appear adjacent to the extracted material. In addition, the reprinted material must include a copyright notice in the following format: "© 2020 UL LLC"