

XHBN.HW-D-0538 - Joint Systems

Design/System/Construction/Assembly Usage Disclaimer

- Authorities Having Jurisdiction should be consulted in all cases as to the particular requirements covering the installation and use of UL Certified products, equipment, system, devices, and materials.
- Authorities Having Jurisdiction should be consulted before construction.
- Fire resistance assemblies and products are developed by the design submitter and have been investigated by UL for compliance with applicable requirements. The published information cannot always address every construction nuance encountered in the field.
- When field issues arise, it is recommended the first contact for assistance be the technical service staff provided by the product manufacturer noted for the design. Users of fire resistance assemblies are advised to consult the general Guide Information for each product category and each group of assemblies. The Guide Information includes specifics concerning alternate materials and alternate methods of construction.
- Only products which bear UL's Mark are considered Certified.

XHBN - Joint Systems XHBN7 - Joint Systems Certified for Canada

See General Information for Joint Systems

See General Information for Joint Systems Certified for Canada

System No. HW-D-0538

March 16, 2020

ANSI/UL2079	CAN/ULC S115
Assembly Ratings — 1 And 2 Hr (See Item 2)	F Ratings — 1 And 2 Hr (See Item 2)
Nominal Joint Width - 1-1/2 In.	FT Ratings — 1 And 2 Hr (See Item 2)
Class II or III Movement Capabilities — 50% Compression or Extension	FH Ratings — 1 And 2 Hr (See Item 2)
L Rating At Ambient — Less Than 1 CFM/Lin Ft	FTH Ratings — 1 And 2 Hr (See Item 2)
L Rating At 400 F — Less Than 1 CFM/Lin Ft	Nominal Joint Width - 38 mm
	Class II or III Movement Capabilities — 50% Compression or Extension
	L Rating At Ambient — Less Than 1 L/s/Lin M
	L Rating At 204 C — Less Than 1.57 L/s/Lin M

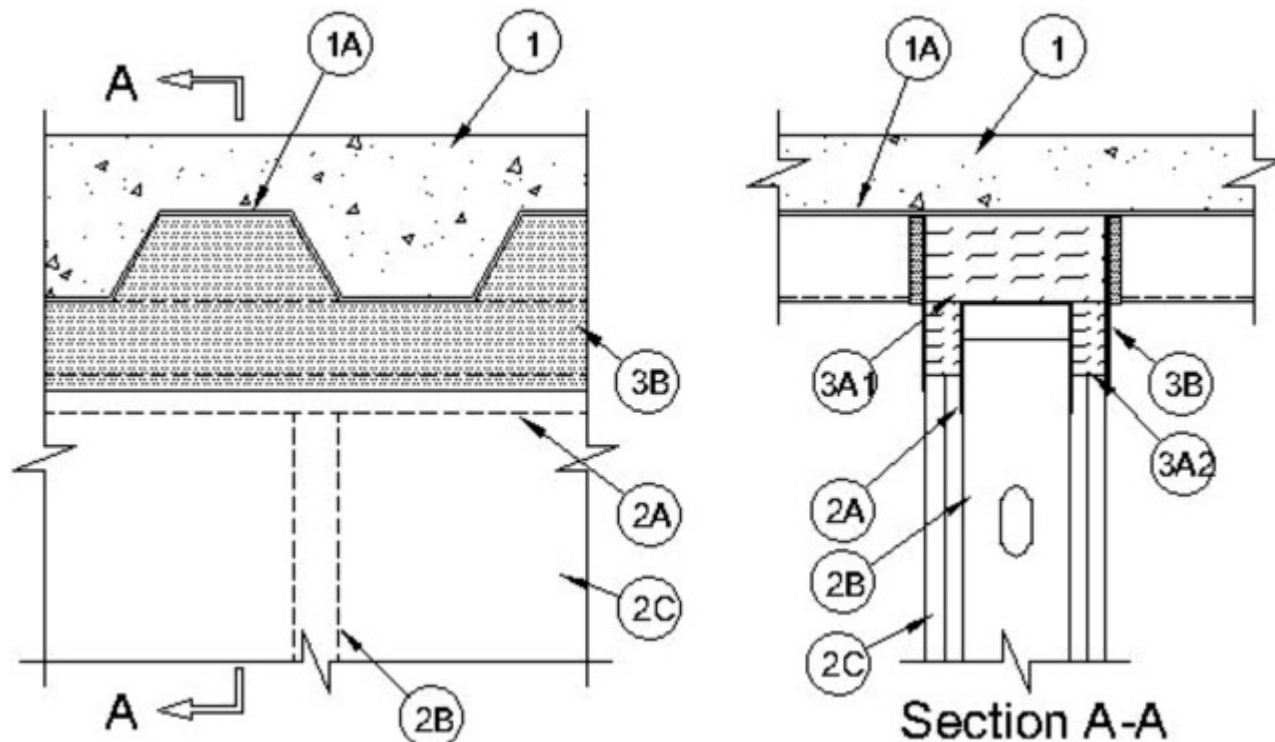

1. Floor Assembly — The fire rated fluted steel deck/concrete floor assembly shall be constructed of the materials and in the manner described in the individual D700 or D900 Series Floor-Ceiling Design in the UL Fire Resistance Directory and shall include the following construction features:

A. **Steel Floor and Form Units*** — Max 3 in. (76 mm) deep galv steel fluted floor units.

B. **Concrete** — Min 2-1/2 in. (64 mm) thick reinforced concrete, as measured from the top plane of the floor units.

C. **Steel Attachment Clips** — (Optional. Not Shown) - Used to secure ceiling runner when spray-applied fire resistive material (Item 1D) is applied to floor units prior to installation of ceiling runner of wall. Z-shaped clips formed from 1 in. (25 mm) wide strips of min 20 ga galv steel. Clips to be sized to extend through the thickness of the spray-applied fire-resistive material on the steel floor unit with 1-1/2 in. (38 mm) long upper and lower legs. Legs of clips fastened to bottom of floor units (prior to application of spray-applied fire-resistive materials) with steel fasteners or welds. Clips spaced max 16 in. (406 mm) OC and extend to within 1/4 to 3/4 in. (6 to 19 mm) from the surface of the wall.

D. **Spray-Applied Fire Resistive Material*** — (Optional. Not Shown) - After installation of the ceiling runner, or prior to installation of the ceiling runner and after installation of the steel attachment clips (Item 1C), the steel floor units may be sprayed with the min thickness of material specified in the individual D700 Series Design.

ISOLATEK INTERNATIONAL — Type 300

GCP APPLIED TECHNOLOGIES INC — Type MK-6/HY

1A. Roof Assembly — (Not Shown) — As an alternate to the floor assembly, a fire rated fluted steel deck roof assembly may be used. The roof assembly shall be constructed of the materials and in the manner described in the individual P900 Series Roof-Ceiling Design in the UL Fire Resistance Directory. The hourly rating of the roof assembly shall be equal to or greater than the hourly rating of the wall assembly. The roof assembly shall include the following construction features:

A. **Steel Roof Deck** — Max 3 in. (76 mm) deep galv steel fluted roof deck.

B. **Roof Insulation** — Min 2-1/4 in. (57 mm) thick poured insulating concrete, as measured from the top plane of the steel roof deck.

1B. Roof Assembly — As an alternate to Items 1 and 1A, a fire rated protected fluted steel deck roof assembly may be used. The roof assembly shall be constructed of the materials and in the manner described in the individual P700 Series Roof-Ceiling

Design in the UL Fire Resistance Directory. The hourly rating of the roof assembly shall be equal to or greater than the hourly rating of the wall assembly. The roof assembly shall include the following construction features:

A. **Steel Roof Deck** — Max 3 in. (76 mm) deep galv steel fluted roof deck.

B. **Steel Attachment Clips** — (Optional. Not Shown) - Used to secure ceiling runner when spray-applied fire resistive material is applied to roof deck prior to installation of ceiling runner of wall. Z-shaped clips formed from 1 in. (25 mm) wide strips of min 20 ga galv steel. Clips to be sized to extend through the thickness of the spray-applied fire-resistive material on the roof deck with 1-1/2 in. (38 mm) long upper and lower legs. Legs of clips fastened to bottom of roof deck (prior to application of spray-applied fire-resistive materials) with steel fasteners or welds. Clips spaced max 24 in. (610 mm) OC and extend to within 1/4 to 3/4 in. (6 to 19 mm) from the surface of the wall.

C. **Spray—Applied Fire Resistive Materials*** — (Not Shown)—Prior to or after the installation of the steel ceiling runners, the roof assembly shall be sprayed with the type and thickness of fire resistive material indicated in the individual P700 Series design.

ISOLATEK INTERNATIONAL — Type 300

GCP APPLIED TECHNOLOGIES INC — Type MK-6/HY

2. **Wall Assembly** — The 1 hr or 2 hr fire rated gypsum board/steel stud wall assembly shall be constructed of the materials and in the manner described in the individual U400 or V400 Series Wall and Partition Design in the UL Fire Resistance Directory and shall include the following construction features:

A. **Steel Floor and Ceiling Runners** — Floor and ceiling runners of wall assembly shall consist of galv steel channels sized to accommodate steel studs (Item 2B). Flange height of ceiling runner shall be min 1/4 in. (6 mm) greater than max extended joint width. Ceiling runner installed perpendicular to the deck direction and secured to valleys of deck with masonry anchors, steel fasteners or welds spaced max 24 in. (610 mm) OC. For floor or roof decks with spray-applied fire resistive material, ceiling runner attached to steel attachment clips (Item 1C) with masonry anchors, steel fasteners or welds spaced max 24 in. (610 mm) OC.

A1. **Light Gauge Framing*-Slotted Ceiling Runner** — As an alternate to the ceiling runner in Item 2A, slotted ceiling runner to consist of galv steel channel with slotted flanges sized to accommodate steel studs (Item 2B). Slotted ceiling runner installed perpendicular to direction of fluted steel deck and secured to valleys before or after optional spray-applied fire resistive material is used with steel masonry anchors, steel fasteners or welds spaced max 24 in. (610 mm) OC. The use of welds to secure the ceiling runner may only be used prior to the installation of the optional spray-applied material.

BRADY CONSTRUCTION INNOVATIONS INC, DBA SLIPTRACK SYSTEMS — SLP-TRK, SLPTRK325

CALIFORNIA EXPANDED METAL PRODUCTS CO — CST, CST325

SCAFCO STEEL STUD MANUFACTURING CO

A2. **Light Gauge Framing* — Slotted Ceiling Runner** — As an alternate to the ceiling runner in Item 2A through 2A1, ceiling runner to consist of galv steel channel with slotted flanges sized to accommodate steel studs (Item 2B). Flange height of slotted ceiling runner shall be 3-1/4 in. (83 mm) with 2 in. (51 mm) deep slots. Slotted ceiling runner installed perpendicular to direction of fluted steel deck and secured to valleys as described in Item A1.

SCAFCO STEEL STUD MANUFACTURING CO — Slotted Track-Type SDLT

B. **Studs** — Steel studs to be min 3-1/2 in. (89 mm) wide. Studs cut 1-1/4 in. to 1-1/2 in. (32 to 38 mm) less in length than assembly height with bottom nesting in and resting on floor runner and with top nesting in ceiling runner without attachment.. Stud spacing not to exceed 24 in. (610 mm) OC. When slotted ceiling runner (Item 2A2) is used, steel studs cut in lengths 3/4 to 1-3/4 in. (19 to 44 mm) less than floor to ceiling height and secured to slotted ceiling runner with No. 8 by 1/2 (13 mm) long wafer head steel screws at +/- 3/16 in. (5 mm) of the mid-height of slot on each side of wall.

C. **Gypsum Board*** — Gypsum board installed to a min total thickness of 5/8 in. (16 mm) or 1-1/4 in. (32 mm) on each side of wall for 1 hr and 2 hr rated assemblies, respectively. Wall to be constructed as specified in the individual Wall and Partition Design in the UL Fire Resistance Directory, except that a nom 1-1/2 in. (38 mm) gap shall be maintained between the top of the gypsum board and the bottom of the steel deck and the top row of screws shall be installed 1 to 1-1/2 in. (25 to 38 mm) below the bottom of the ceiling runner.

The hourly Assembly, F, FT, FH and FTH Ratings of the joint system are dependent on the hourly rating of the wall.

3. **Joint System** — Max separation between bottom plane of floor or roof and top of gypsum board at time of installation of joint system is 1-1/2 in. (38 mm). The joint system is designed to accommodate a max 50 compression or extension from its installed width. The joint system consists of forming material and a fill material as follows:

A. **Forming Material*** — Min 4 pcf (64 kg/m³) forming material sized to attain a min compression rate of 25 percent in the thickness direction and firmly packed to completely fill the flutes. Alternately, nom 4 pcf (64 kg/m³) forming material cut to shape of flute and nom 1 in. (25 mm) longer than thickness of wall; mineral wool compressed from ends and firmly packed into each flute to attain a min compression rate of 14.3 percent in the length (wall thickness) direction to be flush with both wall surfaces. Additional pieces of batt insulation, 5/8 or 1-1/4 in. (16 or 32 mm) wide, shall be compressed 50 percent in thickness and installed cut edge first into gap between bottom of fluted floor or roof units and forming material within flutes, and top of gypsum board.

INDUSTRIAL INSULATION GROUP L L C — MinWool-1200 Safing

JOHNS MANVILLE — Safing

ROCK WOOL MANUFACTURING CO — Delta Board

ROCKWOOL — SAFE

THERMAFIBER INC — Type SAF

A1. **Forming Material*—Plugs** — As an alternate to Item 3A, preformed mineral wool plugs, formed to the shape of the fluted floor units, friction fit to completely fill the flutes above the ceiling runner. The plugs shall project beyond each side of the ceiling runner, flush with wall surfaces. Additional forming material, described in Item 3A2, to be used in conjunction with the plugs to fill the gap between the top of gypsum board and the bottom of plug.

HILTI CONSTRUCTION CHEMICALS, DIV OF HILTI INC — CP777 Speed Plugs

A2. **Forming Material* - Strips** — Nom 5/8 in. (16 mm) and 1-1/4 in. (32 mm) wide precut mineral wool strips for 1 and 2 hr rated assemblies, respectively. The strips are compressed 50 percent in thickness and firmly packed into the gap between the top of the gypsum board and bottom of the steel floor or roof deck on both sides of the wall.

HILTI CONSTRUCTION CHEMICALS, DIV OF HILTI INC — CP 767 Speed Strips

B. **Fill, Void or Cavity Material*** — Min 1/16 in. (1.6 mm) dry thickness (min 1/8 in. or 3.2 mm wet thickness) of fill material sprayed on each side of the wall to completely cover mineral wool forming material and to overlap a min of 1/2 in. (13 mm) onto gypsum board and min of 1/2 in. (13 mm) onto the steel deck or 2 in. (51 mm) onto the spray-applied fire resistive material on steel deck, on both sides of wall.

HILTI CONSTRUCTION CHEMICALS, DIV OF HILTI INC — CFS-SP WB Firestop Joint Spray

*** Indicates such products shall bear the UL or cUL Certification Mark for jurisdictions employing the UL or cUL Certification (such as Canada), respectively.**

The appearance of a company's name or product in this database does not in itself assure that products so identified have been manufactured under UL's Follow-Up Service. Only those products bearing the UL Mark should be considered to be Certified and covered under UL's Follow-Up Service. Always look for the Mark on the product.

UL permits the reproduction of the material contained in the Online Certification Directory subject to the following conditions: 1. The Guide Information, Assemblies, Constructions, Designs, Systems, and/or Certifications (files) must be presented in their entirety and in a non-misleading manner, without any manipulation of the data (or drawings). 2. The statement "Reprinted from the Online Certifications Directory with permission from UL" must appear adjacent to the extracted material. In addition, the reprinted material must include a copyright notice in the following format: "© 2020 UL LLC"