



XHBN.HW-D-0484 - Joint Systems

Design/System/Construction/Assembly Usage Disclaimer

- Authorities Having Jurisdiction should be consulted in all cases as to the particular requirements covering the installation and use of UL Certified products, equipment, system, devices, and materials.
- Authorities Having Jurisdiction should be consulted before construction.
- Fire resistance assemblies and products are developed by the design submitter and have been investigated by UL for compliance with applicable requirements. The published information cannot always address every construction nuance encountered in the field.
- When field issues arise, it is recommended the first contact for assistance be the technical service staff provided by the product manufacturer noted for the design. Users of fire resistance assemblies are advised to consult the general Guide Information for each product category and each group of assemblies. The Guide Information includes specifics concerning alternate materials and alternate methods of construction.
- Only products which bear UL's Mark are considered Certified.

XHBN - Joint Systems

See General Information for Joint Systems

System No. HW-D-0484

September 01, 2016

Assembly Ratings — 1 and 2 Hr (See Item 2)

Maximum Joint Width — 3/4 in.

Class II Movement Capabilities — 25% Compression

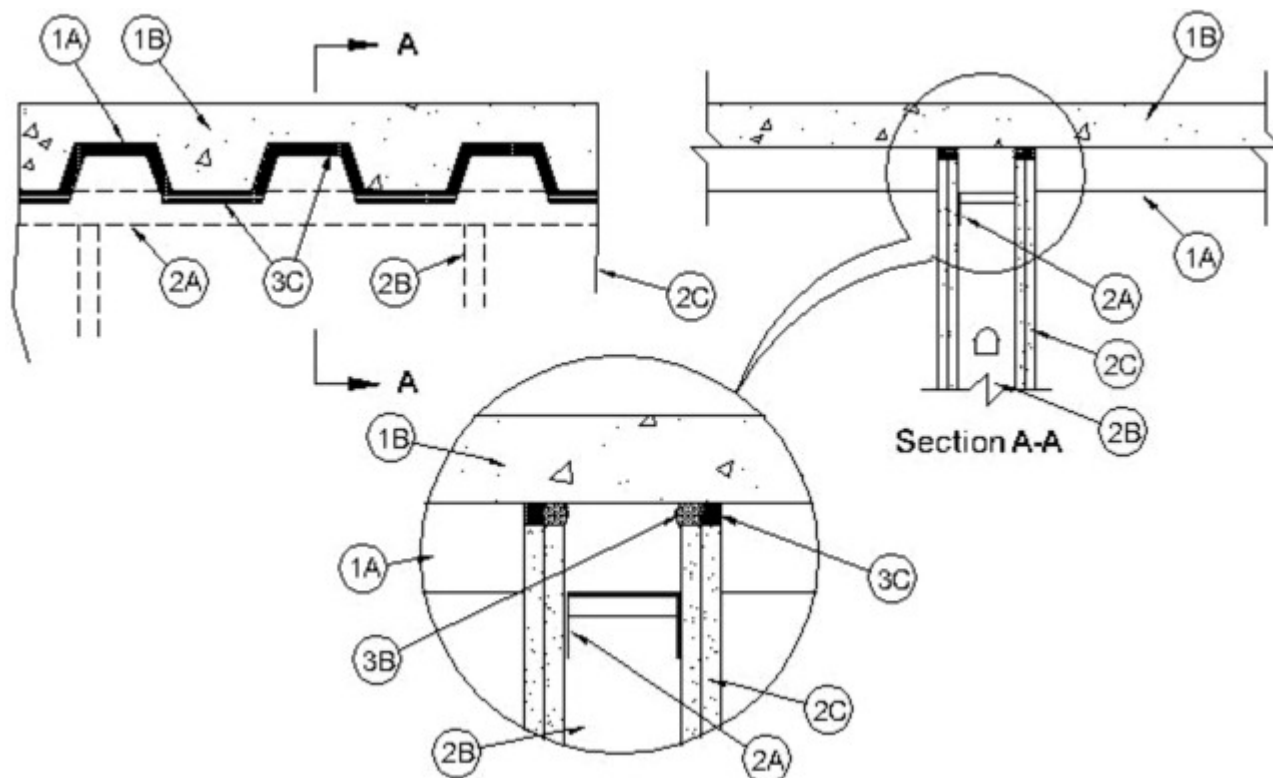

1. **Floor Assembly** — The fire-rated fluted steel deck/concrete floor assembly shall be constructed of the materials and in the manner described in the individual D900 Series Floor-Ceiling Design in the UL Fire Resistance Directory and shall include the following construction features:

A. **Steel Floor And Form Units*** — Max 3 in. (76 mm) deep galv steel fluted floor units.

B. **Concrete** — Min 2-1/2 in. (64 mm) thick reinforced concrete, as measured from the top plane of the floor units.

C. **Spray-Applied Fire Resistive Material*** — (Optional, Not Shown) - After installation of the ceiling runner (Item 2A) or deflection channel (Item 3A), steel floor units to be sprayed with a min 5/16 in. (8 mm) to max 11/16 in. (17 mm) thickness of material in accordance with the specifications in the individual D700 or D800 Series Design. When spray applied fire resistive material is used, ceiling runner or deflection channel to be provided with 2 in. (51 mm) flanges. Excess material to be scraped from flanges of ceiling runner or deflection channel prior to installation of gypsum board.

ISOLATEK INTERNATIONAL — Type 300

GCP APPLIED TECHNOLOGIES INC — MK-6/HY

1A. **Roof Assembly** — (Not Shown) — As an alternate to the floor assembly (Item 1), a fire rated fluted steel deck roof assembly may be used. The roof assembly shall be constructed of the materials and in the manner described in the individual P700, P800 or P900 Series Roof-Ceiling Design in the UL Fire Resistance Directory. The hourly fire rating of the roof assembly shall be equal to or greater than the hourly fire rating of the wall assembly. The roof assembly shall include the following construction features:

A. **Steel Roof Deck** — Max 3 in. (76 mm) deep galv steel fluted roof deck.

B. **Roof Insulation** — Min 2-1/4 in. (57 mm) thick poured insulating concrete, as measured from the top plane of the steel roof deck.

C. **Roof Covering*** — Hot-mopped or cold-application materials compatible with insulating concrete.

D. **Spray-Applied Fire Resistive Material*** — (Optional, Not Shown) - After installation of the ceiling runner (Item 2A) or deflection channel (Item 3A), steel floor units to be sprayed with a min 5/16 in. (8 mm) to max 11/16 in. (17 mm)

thickness of material in accordance with the specifications in the individual P700 or P800 Series Design. When spray applied fire resistive material is used, ceiling runner or deflection channel to be provided with 2 in. (51 mm) flanges. Excess material to be scraped from flanges of ceiling runner or deflection channel prior to installation of gypsum board.

ISOLATEK INTERNATIONAL — Type 300

GCP APPLIED TECHNOLOGIES INC — MK-6/HY

2. Wall Assembly — The 1 or 2 hr fire rated gypsum board/stud wall assembly shall be constructed of the materials and in the manner described in the individual U400 Series Wall or Partition Design in the UL Fire Resistance Directory and shall include the following construction features:

A. Steel Floor And Ceiling Runners — Floor and ceiling runners of wall assembly shall consist of galv steel channels sized to accommodate steel studs . Ceiling runner to be provided with min 1-1/4 in. (32 mm) to max 2 in. (51 mm) flanges. When deflection channel (Item 3A) is used, flange height of ceiling runner is to be equal to or greater than flange height of deflection channel and the ceiling runner is to nest within the deflection channel with a 1/2 in. (13 mm) to 3/4 in. (19 mm) gap maintained between the top of the ceiling runner and the top of the deflection channel. Ceiling runner secured to valleys with steel masonry anchors or welds spaced max 24 in. (610 mm) OC.

A1. Light Gauge Framing* — Clipped Ceiling Runner — As an alternate to the ceiling runner in Item 2A, clipped runner to consist of galv steel channel with clips preformed in track flanges which positively engage the inside flange of the steel studs (Item 2B). Track sized to accommodate steel studs (Item 2B). Track flanges to be min 2-1/2 in. (64 mm) long. Clipped ceiling runner installed perpendicular to direction of fluted steel deck and secured to valleys with steel masonry anchors spaced max 24 in. (610 mm) OC. When clipped ceiling runner is used, deflection channel (Item 3A) shall not be used.

TOTAL STEEL SOLUTIONS L L C — Snap Trak

A2. Light Gauge Framing* - Notched Ceiling Runner — As an alternate to the ceiling runners in Items 2A and 2A1, notched ceiling runners to consist of C-shaped galv steel channel with notched return flanges sized to accommodate steel studs (Item 2B). Notched ceiling runner installed perpendicular to direction of fluted steel deck and secured to valleys with steel masonry anchors spaced max 24 in. (610 mm) OC. When notched ceiling runner is used, deflection channel (Item 3A) shall not be used.

OLMAR SUPPLY INC — Type SCR

A3. Light Gauge Framing* — Slotted Ceiling Runner — Slotted ceiling runner may be used as an alternate to the ceiling runner in Item 2A. Slotted ceiling runner to consist of galv steel channel with slotted flanges sized to accommodate steel studs (Item 3B). Ceiling runner installed perpendicular to direction of fluted steel deck and secured to valleys with steel masonry anchors spaced max 24 in. (610 mm) OC. When slotted ceiling runner is used, deflection channel (Item 3A) shall not be used.

BRADY CONSTRUCTION INNOVATIONS INC, DBA SLIPTRACK SYSTEMS — SLP-TRK

CALIFORNIA EXPANDED METAL PRODUCTS CO — CST

CLARKDIETRICH BUILDING SYSTEMS — Type SLT, SLT-H

MARINO/WARE, DIV OF WARE INDUSTRIES INC — Type SLT

METAL-LITE INC — The System

RAM SALES L L C — RAM Slotted Track

B. **Studs** — Steel studs to be min 3-1/2 in. (89 mm) wide. Studs cut 1/2 in. (13 mm) to 3/4 in. (19 mm) less in length than assembly height with bottom nesting in and secured to floor runner. When deflection channel (Item 3A) is used, steel studs attached to ceiling runner with sheet metal screws located 1/2 in. (13 mm) below the bottom of the deflection channel. When deflection channel is not used, studs to nest in ceiling runner without attachment.

C. **Gypsum Board*** — Gypsum board sheets installed to a min total thickness of 5/8 in. (16 mm) and 1-1/4 in. (32 mm) on each side of wall for 1 and 2 hr fire rated assemblies, respectively. Wall to be constructed as specified in the individual Wall and Partition Design in the UL Fire Resistance Directory, except that the gypsum board is cut to follow the contour of the steel floor units with a nom 3/4 in. (19 mm) gap maintained between the gypsum board and the steel deck. In addition, the top row of screws shall be installed into the steel studs 1/2 to 1 in. (13 to 25 mm) below the bottom edge of the ceiling runner flange.

The hourly fire rating of the joint system is dependent on the hourly fire rating of the wall assembly in which it is installed.

3. **Joint System** — Max separation between bottom of floor or roof deck and top of wall is 3/4 in. (19 mm). The joint system is designed to accommodate a max 25 percent compression from its installed width. The joint system consists of the following:

A. **Deflection Channel** — (Optional, Not Shown) - Max 2 in. (51 mm) deep min 24 gauge galv steel channel sized to accommodate ceiling runner (Item 2A). Deflection channel installed perpendicular to direction of fluted steel deck and secured to valleys with steel masonry anchors or welds spaced max 24 in. (610 mm) OC. The ceiling runner is installed within the deflection channel to maintain a 1/2 in. (13 mm) to 3/4 in. (19 mm) gap between the top of the ceiling runner and the top of the deflection channel. The ceiling runner is not fastened to the deflection channel.

B. **Forming Material** — (Optional, Not Shown) - In 2 hr fire rated wall assemblies, foam backer rod friction fit into joint opening and recessed minimum 1/2 in. (13 mm) from each surface of wall.

C. **Fill, Void or Cavity Material* - Sealant** — Min 5/8 in. (16 mm) thickness of fill material applied within joint opening on both sides of wall, flush with both surfaces of wall. As an option in 1 hr fire rated walls, bond breaker tape applied to ceiling channel (Item 2A) or deflection channel (Item 3A) prior to installation of fill material.

SPECIFIED TECHNOLOGIES INC — SpecSeal LC150 Sealant, SpecSeal LE600 Sealant

*** Indicates such products shall bear the UL or cUL Certification Mark for jurisdictions employing the UL or cUL Certification (such as Canada), respectively.**

Last Updated on 2016-09-01

The appearance of a company's name or product in this database does not in itself assure that products so identified have been manufactured under UL's Follow-Up Service. Only those products bearing the UL Mark should be considered to be Certified and covered under UL's Follow-Up Service. Always look for the Mark on the product.

UL permits the reproduction of the material contained in the Online Certification Directory subject to the following conditions: 1. The Guide Information, Assemblies, Constructions, Designs, Systems, and/or Certifications (files) must be presented in their entirety and in a non-misleading manner, without any manipulation of the data (or drawings). 2. The statement "Reprinted from the Online Certifications Directory with permission from UL" must appear adjacent to the extracted material. In addition, the reprinted material must include a copyright notice in the following format: "© 2020 UL LLC"