



XHBN.HW-D-0483 - Joint Systems

Design/System/Construction/Assembly Usage Disclaimer

- Authorities Having Jurisdiction should be consulted in all cases as to the particular requirements covering the installation and use of UL Certified products, equipment, system, devices, and materials.
- Authorities Having Jurisdiction should be consulted before construction.
- Fire resistance assemblies and products are developed by the design submitter and have been investigated by UL for compliance with applicable requirements. The published information cannot always address every construction nuance encountered in the field.
- When field issues arise, it is recommended the first contact for assistance be the technical service staff provided by the product manufacturer noted for the design. Users of fire resistance assemblies are advised to consult the general Guide Information for each product category and each group of assemblies. The Guide Information includes specifics concerning alternate materials and alternate methods of construction.
- Only products which bear UL's Mark are considered Certified.

XHBN - Joint Systems

XHBN7 - Joint Systems Certified for Canada

See General Information for Joint Systems

See General Information for Joint Systems Certified for Canada

System No. HW-D-0483

September 01, 2016

ANSI/UL2079

CAN/ULC S115

Assembly Ratings — 1 and 2 Hr (See Item 3)	F Ratings — 2 Hr
Nominal Joint Width — 3/4 In.	FT Ratings — 2 Hr
Class II Movement Capabilities — 25% Compression, 12.5% Extension	FH Ratings — 2 Hr
	FTH Ratings — 2 Hr
	Nominal Joint Width — 102 mm
	Class II Movement Capabilities — 25% Compression, 12.5% Extension

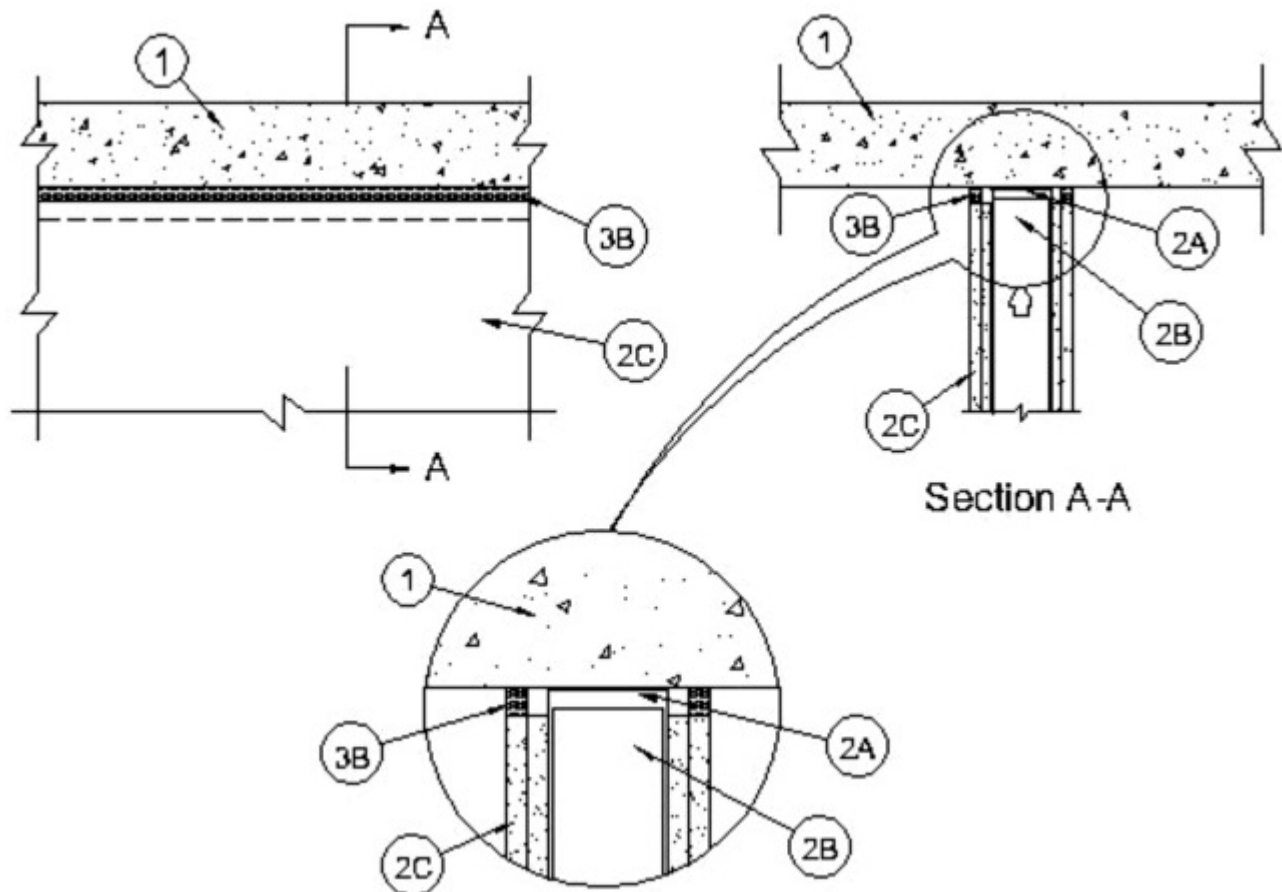

1. **Floor Assembly** — Min 4-1/2 in. (114 mm) thick steel-reinforced lightweight or normal weight (100-150 pcf or 1600-2400 kg/m³) structural concrete. Floor may also be constructed of any UL Classified hollow-core **Precast Concrete Units***. See **Precast Concrete Units** (CFTV) in Fire Resistance Directory for names of manufacturers.

2. **Wall Assembly** — The 1 or 2 hr fire-rated gypsum board/stud wall assembly shall be constructed of the materials and in the manner described in the individual U400 or V400 Series Wall and Partition Design in the UL Fire Resistance Directory and shall include the following construction features:

A. **Steel Floor and Ceiling Runners** — Floor and ceiling runners of wall assembly shall consist of galv steel channels sized to accommodate steel studs (Item 2B) with min 1-1/4 in. (32 mm) long flanges. Ceiling runner secured to concrete floor slab with steel masonry anchors spaced max 24 in. (610 mm) OC.

A1. **Light Gauge Framing* — Clipped Ceiling Runner** — As an alternate to the ceiling runner in Item 2A, clipped runner to consist of galv steel channel with clips preformed in track flanges which positively engage the inside flange of the steel studs (Item 2B). Track sized to accommodate steel studs (Item 2B). Track flanges to be min 2-1/2 in. (64 mm) long. Clipped ceiling runner secured to concrete floor slab with steel masonry anchors spaced max 24 in. (610 mm) OC.

CALIFORNIA EXPANDED METAL PRODUCTS CO — CST

TOTAL STEEL SOLUTIONS L L C — Snap Trak

MARINO/WARE, DIV OF WARE INDUSTRIES INC — Type SLT

A2. **Light Gauge Framing* - Slotted Ceiling Runner** — As an alternate to the ceiling runner in Item 2A, ceiling runner to consist of galv steel channel with slotted flanges sized to accommodate steel studs (Items 2B). Ceiling runner secured to concrete floor slab with steel masonry anchors spaced max 24 in. (610 mm) OC.

BRADY CONSTRUCTION INNOVATIONS INC, DBA SLIPTRACK SYSTEMS — SLP-TRK

CLARKDIETRICH BUILDING SYSTEMS — Type SLT, SLT-H**METAL-LITE INC** — The System**RAM SALES L L C** — RAM Slotted Track

A3. Light Gauge Framing* - Vertical Deflection Ceiling Runner — As an alternate to the ceiling runner in Item 2A, vertical deflection ceiling runner to consist of galv steel channel with slotted vertical deflection clips mechanically fastened within runner. Slotted clip provided with step bushings for permanent fastening of steel studs. Flanges sized to accommodate steel studs (Item 2B). Vertical deflection ceiling runner secured to concrete floor slab with steel masonry anchors spaced max 24 in. (610 mm) OC.

THE STEEL NETWORK INC — VertiTrack VTD358, VTD400, VTD600 and VTD800

A4. Light Gauge Framing* - Notched Ceiling Runner — As an alternate to the ceiling runners in Items 2A through 2A3, notched ceiling runners to consist of C-shaped galv steel channel with notched return flanges sized to accommodate steel studs (Item 2B). Notched ceiling runner secured to concrete floor slab with steel masonry anchors spaced max 24 in. (610 mm) OC.

OLMAR SUPPLY INC — Type SCR

B. Studs — Steel studs to be min 3-1/2 in. (89 mm) wide. Studs cut 1/2 in. (13 mm) to 3/4 in. (19 mm) less in length than assembly height with bottom nesting in and resting on floor runner and with top nesting in ceiling runner without attachment. When deflection channel (Item 3A) is used, steel studs attached to ceiling runner with sheet metal screws located 1/2 in. (13 mm) below the bottom of the deflection channel. When slotted ceiling runner (Item 2A2) is used, steel studs secured to slotted ceiling runner with No. 8 by 1/2 in. (13 mm) long wafer head steel screws at midheight of slot on each side of wall. When vertical deflection ceiling runner (Item 2A3) is used, steel studs secured to slotted vertical deflection clips, through bushings, with steel screws at midheight of each slot. Stud spacing not to exceed 24 in. (610 mm) OC.

C. Gypsum Board* — Gypsum board sheets installed to a min total thickness of 5/8 in. (16 mm) and 1-1/4 in. (32 mm) on each side of wall for 1 and 2 hr fire rated assemblies, respectively. Wall to be constructed as specified in the individual Wall and Partition Design in the UL Fire Resistance Directory, except that a max 3/4 in. (19 mm) gap shall be maintained between the top of the gypsum board and the bottom surface of the floor. In addition, the top row of screws shall be installed into the steel studs 1/2 to 1 in. (13 to 25 mm) below the bottom edge of the ceiling runner flange.

The hourly fire rating of the joint system is dependent on the hourly fire rating of the wall assembly in which it is installed.

3. Joint System — Max separation between bottom of floor and top of wall is 3/4 in. (19 mm). The joint system is designed to accommodate a max 25 percent compression and 12.5 percent extension from its installed width. . The joint system consists of the following:

A. Forming Material — (Optional, Not Shown) — In 2 hr fire rated wall assemblies, polyethylene backer rod, mineral wool batt insulation or fiberglass batt insulation friction fit into joint opening.

B. Fill, Void or Cavity Material* — Sealant — Min 5/8 in. (16 mm) thickness of fill material applied within joint opening on both sides of wall, flush with both surfaces of wall. As an option in 1 hr fire rated walls, bond breaker tape applied to ceiling channel (Item 2A) prior to installation of fill material.

SPECIFIED TECHNOLOGIES INC — SpecSeal LC150 Sealant, SpecSeal LE600 Sealant

*** Indicates such products shall bear the UL or cUL Certification Mark for jurisdictions employing the UL or cUL Certification (such as Canada), respectively.**

Last Updated on 2016-09-01

The appearance of a company's name or product in this database does not in itself assure that products so identified have been manufactured under UL's Follow-Up Service. Only those products bearing the UL Mark should be considered to be Certified and covered under UL's Follow-Up Service. Always look for the Mark on the product.

UL permits the reproduction of the material contained in the Online Certification Directory subject to the following conditions: 1. The Guide Information, Assemblies, Constructions, Designs, Systems, and/or Certifications (files) must be presented in their entirety and in a non-misleading manner, without any manipulation of the data (or drawings). 2. The statement "Reprinted from the Online Certifications Directory with permission from UL" must appear adjacent to the extracted material. In addition, the reprinted material must include a copyright notice in the following format: "© 2020 UL LLC"