

XHBN.HW-D-0377 - Joint Systems

Design/System/Construction/Assembly Usage Disclaimer

- Authorities Having Jurisdiction should be consulted in all cases as to the particular requirements covering the installation and use of UL Certified products, equipment, system, devices, and materials.
- Authorities Having Jurisdiction should be consulted before construction.
- Fire resistance assemblies and products are developed by the design submitter and have been investigated by UL for compliance with applicable requirements. The published information cannot always address every construction nuance encountered in the field.
- When field issues arise, it is recommended the first contact for assistance be the technical service staff provided by the product manufacturer noted for the design. Users of fire resistance assemblies are advised to consult the general Guide Information for each product category and each group of assemblies. The Guide Information includes specifics concerning alternate materials and alternate methods of construction.
- Only products which bear UL's Mark are considered Certified.

XHBN - Joint Systems XHBN7 - Joint Systems Certified for Canada

See General Information for Joint Systems

See General Information for Joint Systems Certified for Canada

System No. HW-D-0377

September 26, 2019

ANSI/UL2079	CAN/ULC S115
Assembly Ratings — 1 and 2 Hr (See Item 2)	F Ratings — 1 and 2 Hr (See Item 2)
Nominal Joint Width - 1-1/2 In.	FT Ratings — 1 and 2 Hr (See Item 2)
Class II Movement Capabilities - 12.5% or 50% Compression or Extension (See Item 3)	FH Ratings — 1 and 2 Hr (See Item 2)
L Rating At Ambient — Less Than 1 CFM/sq ft	FTH Ratings — 1 and 2 Hr (See Item 2)
L Rating At 400 F — Less Than 1 CFM/sq ft	Nominal Joint Width - 1-1/2 In.
	Class II Movement Capabilities - 12.5% or 50% Compression or Extension (See Item 3)
	L Rating At Ambient — Less Than 1 CFM/sq ft
	L Rating At 400 F — Less Than 1 CFM/sq ft

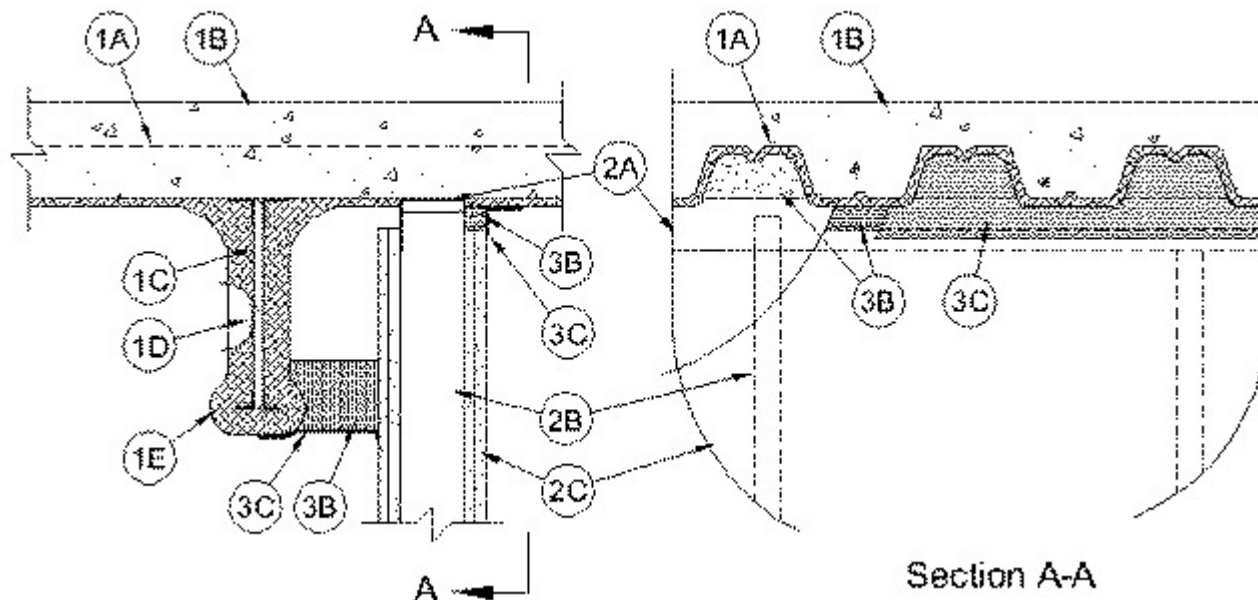

1. Floor Assembly — The fire-rated fluted steel deck/concrete floor assembly shall be constructed of the materials and in the manner described in the individual D700, D800, or D900 Series Floor-Ceiling Design in the UL Fire Resistance Directory. The hourly fire rating of the floor assembly shall be equal to or greater than the hourly fire rating of the wall assembly. The floor assembly shall include the following construction features:

A. **Steel Floor and Floor Units*** — Max 3 in. (76 mm) deep galv steel fluted floor units.

B. **Concrete** — Min 2-1/2 in. (64 mm) thick reinforced concrete, as measured from the top plane of the floor units.

C. **Structural Steel Support** — Steel beam or open-web steel joist, as specified in the individual D700, D800, or D900 Series Floor-Ceiling Design, used to support steel floor units. Structural steel support oriented parallel to and 1 to 6 in. (25 to 152 mm) from wall assembly.

D. **Steel Lath** — When structural steel support (Item 1C) consists of open-web steel joists, 3/8 in. (10 mm) diamond mesh expanded steel lath having a nom weight of 1.7 to 3.4 lb per sq yd (0.9 to 1.8 kg/m²) shall be installed to completely cover one side of each joist which is located within 6 in. (152 mm) of wall assembly. The lath shall be secured with steel tie wire and shall be fully covered with spray applied fire resistive material.

E. **Spray-Applied Fire Resistive Material*** — After installation of the ceiling runner (Item 2A) or deflection track (Item 3A, if used), steel floor units and structural steel supports to be sprayed with the thickness of material specified in the individual D700, D800, or D900 Series Design. The flutes of the steel floor units above the structural steel supports and above the ceiling runner (Item 2A) or deflection channel (Item 3A) shall be filled with spray-applied fire resistive material. As an alternate, the spray-applied fire resistive material in the flutes above the ceiling runner may be applied to follow the contour of the steel floor units. Excess material shall be removed from the flanges of the ceiling runner or deflection track beyond the required thickness of spray-applied fire resistive material on the steel floor units. For D900 Series Designs structural steel supports, steel furring and steel lath only to be sprayed in accordance with the specifications in the individual D900 Series Design.

ISOLATEK INTERNATIONAL — Type 300 or Type II

GCP APPLIED TECHNOLOGIES INC — Type MK-6/HY, MK-6/HYES, MK-65 and RG.

1A. Roof Assembly — (Not Shown) — As an alternate to the floor assembly (Item 1), a fire rated fluted steel deck roof assembly may be used. The roof assembly shall be constructed of the materials and in the manner described in the individual P700 or P800 Series Roof-Ceiling Design in the UL Fire Resistance Directory. The hourly fire rating of the roof assembly shall be equal to or greater than the hourly fire rating of the wall assembly. The roof assembly shall include the following construction features:

A. **Steel Roof Deck** — Max 3 in. (76 mm) deep galv steel fluted roof deck.

B. Roof Insulation — Mineral and Fiber Board* — Min 3/4 in. (19 mm) thick boards applied in one or more layers directly over steel roof deck or over gypsum board sheathing laid atop steel roof deck.

C. Roof Covering* — Hot-mopped or cold-application materials compatible with mineral and fiber board insulation.

D. Structural Steel Support — Steel beam or open-web steel joist, as specified in the individual P700 or P800 Series Roof-Ceiling Design, used to support steel floor units. Structural steel support oriented parallel to and 1 in. to 6 in. (25 to 152 mm) from wall assembly.

E. Steel Lath — When structural steel support (Item 1D) consists of open-web steel joists, 3/8 in. (10 mm) diamond mesh expanded steel lath having a nom weight of 1.7 to 3.4 lb per sq yd (0.9 to 1.8 kg/m²) shall be installed to completely cover one side of each joist which is located within 6 in. (152 mm) of wall assembly. The lath shall be secured with steel tie wire and shall be fully covered with spray applied fire resistive material.

F. Spray-Applied Fire Resistive Material* — After installation of the ceiling runner (Item 2A) or deflection track (Item 3A, if used), steel roof deck and structural steel supports to be sprayed with a thickness of spray applied fire resistive material as specified in the individual P700 or P800, or P900 Series Roof-Ceiling design. The flutes of the steel deck above the structural steel supports and above the ceiling runner (Item 2A) or deflection channel (Item 3A) shall be filled with spray-applied fire resistive material. As an alternate, the spray-applied fire resistive material in the flutes above the ceiling runner may be applied to follow the contour of the steel roof deck. Excess material shall be removed from the flanges of the ceiling runner or deflection track beyond the required thickness of spray-applied fire resistive material on the steel roof deck. For P900 Series Designs structural steel supports, steel furring and steel lath only to be sprayed in accordance with the specifications in the individual P900 Series Design.

ISOLATEK INTERNATIONAL — Type 300 or Type II

GCP APPLIED TECHNOLOGIES INC — Type MK-6/HY, MK-6/HYES, MK-65 and RG.

2. Wall Assembly — The 1 or 2 hr fire rated gypsum board/steel stud wall assembly shall be constructed of the materials and in the manner described in the individual U400, V400 or W400 Series Wall and Partition Design in the UL Fire Resistance Directory and shall include the following construction features:

A. Steel Floor and Ceiling Runners — Floor and ceiling runners of wall assembly shall consist of galv steel channels sized to accommodate steel studs (Item 2B). Ceiling runner to be provided with min 2 in. (51 mm) to max 3 in. (76 mm) flanges. When deflection channel (Item 3A) is used, flange height of ceiling runner is to be equal to or greater than flange height of deflection channel and the ceiling runner is to nest within the deflection channel with a 1/2 in. (13 mm) to 1-1/4 in. (32 mm) gap maintained between the top of the ceiling runner and the top of the deflection channel. When deflection channel is not used, flange height of ceiling runner shall be min 1/4 in. (6 mm) greater than max extended joint width and ceiling runner is secured to steel floor units (Item 1A) with steel fasteners or welds spaced max 24 in. (610 mm) OC. Ceiling runner or deflection track to be installed parallel with structural steel support and located such that a max clearance of 6 in. (152 mm) is present between the finished wall and the spray-applied fire resistive material at the lowest elevation of the structural steel support.

A1. Light Gauge Framing* — Slotted Ceiling Runner — As an alternate to the ceiling runner in Item 2A, ceiling runner to consist of galv steel channel with slotted flanges sized to accommodate steel studs (Item 2B). Ceiling runner secured to valleys with steel fasteners spaced max 24 in. (610 mm) OC. When slotted ceiling runner is used, deflection channel (Item 3A) shall not be used.

CALIFORNIA EXPANDED METAL PRODUCTS CO — CST

BRADY CONSTRUCTION INNOVATIONS INC, DBA SLIPTRACK SYSTEMS — SLP-TRK

MARINO/WARE, DIV OF WARE INDUSTRIES INC — Type SLT

A2. **Light Gauge Framing* — Clipped Ceiling Runner** — As an alternate to the ceiling runner in Items 2A and 2A1, clipped runner to consist of galv steel channel with clips preformed in track flanges which positively engage the inside flange of the steel studs (Item 2B). Track sized to accommodate steel studs (Item 2B). Track flanges to be min 2-1/2 in. (64 mm). Clipped ceiling runner secured with steel fasteners spaced max 24 in. (610 mm) OC. When clipped ceiling runner is used, deflection channel (Item 3A) shall not be used.

TOTAL STEEL SOLUTIONS L L C — Snap Trak

B. **Studs** — Steel studs to be min 3-1/2 in. (89 mm) wide. Studs cut 1/2 in. to 1-1/4 in. (13 to 32 mm) less in length than assembly height with bottom nesting in and secured to floor runner. When slotted ceiling runner (Item 2A1) is used, steel studs secured to slotted ceiling runner with No. 8 by 1/2 (13 mm) long wafer head steel screws at midheight of slot on each side of wall. When deflection channel (Item 3A) is used, steel studs attached to ceiling runner (Item 2A) with sheet metal screws located 1/2 in. (13 mm) below the bottom of the deflection channel. When deflection channel is not used, studs to nest in ceiling runner without attachment.

C. **Gypsum Board*** — Gypsum board sheets installed to a min total 5/8 in. (16 mm) or 1-1/4 in. (32 mm) thickness on each side of wall for 1 and 2 hr fire rated assemblies, respectively. Wall to be constructed as specified in the individual U400 or V400 Series Design in the UL Fire Resistance Directory except that a max 1 in. (25 mm) gap shall be maintained between the top of the gypsum board and the bottom plane of the spray applied fire resistive material on the steel deck. on both sides of the wall assembly. The screws attaching the gypsum board to the studs along the top of the wall shall be located 1 in. (25 mm) below the bottom of the ceiling runner. No gypsum board attachment screws shall be driven into the ceiling runner or into the optional deflection channel. Where the top of the wall assembly is inaccessible above the lowest elevation of the structural steel support, the gypsum board attachment screws may be omitted.

The hourly fire rating of the joint system is equal to the hourly fire rating of the wall.

A3. **Light Gauge Framing* - Slotted Ceiling Runner** — As an alternate to the ceiling runner in Item 2A, slotted ceiling runner to consist of galv steel channel with slotted flanges, sized to accommodate steel studs (Item 2B). Slotted ceiling runner installed perpendicular to direction of fluted steel deck and secured to steel deck valleys with steel masonry anchors spaced max 24 in. (610 mm) OC. When slotted ceiling runner is used, deflection channel shall not be used.

CALIFORNIA EXPANDED METAL PRODUCTS CO — CST

3. Joint System — Max vertical separation between bottom plane of steel floor unit and top of gypsum board (at time of installation of joint system) is 1-1/2 in. (38 mm). Max horizontal separation between spray applied fire resistive material on structural support member and surface of wall is 6 in. (152 mm). The joint system is designed to accommodate a max 12.5 or 50 percent compression or extension from its installed width as measured between the bottom plane of the spray-applied fire resistive material on the steel floor unit and the top of the gypsum board. The movement capabilities are dependent on the horizontal separation between the spray applied fire resistive material on the structural support member and the surface of the wall. The joint will accommodate max 12.5 percent compression or extension when the horizontal separation between the spray applied fire resistive material on the structural support member and the surface of the wall is max 3 in. (76 mm). The joint will accommodate max 50 percent compression or extension when the horizontal separation between the spray applied fire resistive material on the structural support member and the surface of the wall is greater than 3 in. (76 mm) up to a max of 6 in. (152 mm). The joint system shall consist of forming and fill materials, with or without a deflection channel (Item 3A), as follows:

A. **Deflection Channel** — (Optional, Not Shown) — Max 2 in. (51 mm) deep min 24 gauge galv steel channel sized to accommodate ceiling runner (Item 2A). Deflection channel to be installed parallel with structural steel support and located such that a max clearance of 4 in. (102 mm) is present between the finished wall and the spray-applied fire resistive material at the lowest elevation of the structural steel support. Deflection channel secured to steel floor units with steel fasteners or welds spaced max 24 in. (610 mm) OC. The ceiling runner (Item 2A) is installed within the deflection channel to maintain a 1/2 in. to 1-1/4 in. (13 to 32 mm) gap between the top of the ceiling runner and the top of the deflection channel. The ceiling runner nests inside the deflection channel without attachment.

B. **Forming Material*** — Nom 4 pcf (64 kg/m³) density mineral wool batt insulation. Sections of mineral wool batt cut to a width of 4 in. (102 mm) and stacked to attain a thickness which is 50 percent greater than the width of the linear gap between the spray applied fire resistive material on the structural steel member and the surface of the wall

assembly. Stacked sections of mineral wool compressed 33 percent in thickness and installed cut edge first into linear gap until the bottom edge is flush with the bottom surface of the spray applied fire resistive material on the structural steel member. When the spray-applied fire resistive material in the flutes above the wall follows the contour of the steel deck, sections of mineral wool batt cut to the shape of the fluted deck and stacked to a min 6 in. (152 mm) thickness shall be installed in the flutes of the steel floor or roof deck between the top of the deflection channel and the spray-applied fire resistive material. The mineral wool batt insulation is to be installed flush with the gypsum board surface on the side of the wall opposite the structural steel support. Additional sections of mineral wool batt insulation are compressed 50 percent in thickness and are installed cut edge first to completely fill the gap above the top of the gypsum board.

INDUSTRIAL INSULATION GROUP L L C — MinWool-1200 Safing

JOHNS MANVILLE — Safing

ROCK WOOL MANUFACTURING CO — Delta Board

ROCKWOOL MALAYSIA SDN BHD — SAFE

ROCKWOOL — SAFE

THERMAFIBER INC — Type SAF

C. Fill, Void or Cavity Material* — Sealant — Min 1/8 in. (3.2 mm) wet thickness (min 1/16 in. or 1.6 mm dry thickness) of fill material spray applied over the forming material on each side of the wall. Fill material to overlap a min of 1/2 in. (13 mm) onto the gypsum board and a min 2 in. (51 mm) onto the spray applied material (Item 1E or 1AE) on the steel floor unit or on the structural steel support member on each side of the wall. Overlap onto the steel floor or roof units may be decreased to 1/2 in. (13 mm) when spray applied material is omitted.

SPECIFIED TECHNOLOGIES INC — SpecSeal AS200 Elastomeric Spray

*** Indicates such products shall bear the UL or cUL Certification Mark for jurisdictions employing the UL or cUL Certification (such as Canada), respectively.**

Last Updated on 2019-09-26

The appearance of a company's name or product in this database does not in itself assure that products so identified have been manufactured under UL's Follow-Up Service. Only those products bearing the UL Mark should be considered to be Certified and covered under UL's Follow-Up Service. Always look for the Mark on the product.

UL permits the reproduction of the material contained in the Online Certification Directory subject to the following conditions: 1. The Guide Information, Assemblies, Constructions, Designs, Systems, and/or Certifications (files) must be presented in their entirety and in a non-misleading manner, without any manipulation of the data (or drawings). 2. The statement "Reprinted from the Online Certifications Directory with permission from UL" must appear adjacent to the extracted material. In addition, the reprinted material must include a copyright notice in the following format: "© 2020 UL LLC"