



# XHBN.HW-D-0313 - Joint Systems

## Design/System/Construction/Assembly Usage Disclaimer

- Authorities Having Jurisdiction should be consulted in all cases as to the particular requirements covering the installation and use of UL Certified products, equipment, system, devices, and materials.
- Authorities Having Jurisdiction should be consulted before construction.
- Fire resistance assemblies and products are developed by the design submitter and have been investigated by UL for compliance with applicable requirements. The published information cannot always address every construction nuance encountered in the field.
- When field issues arise, it is recommended the first contact for assistance be the technical service staff provided by the product manufacturer noted for the design. Users of fire resistance assemblies are advised to consult the general Guide Information for each product category and each group of assemblies. The Guide Information includes specifics concerning alternate materials and alternate methods of construction.
- Only products which bear UL's Mark are considered Certified.

## XHBN - Joint Systems

### XHBN7 - Joint Systems Certified for Canada

See General Information for Joint Systems

See General Information for Joint Systems Certified for Canada

### System No. HW-D-0313

September 01, 2016

| ANSI/UL2079   | CAN/ULC S115  |
|---|---|
| Assembly Rating — 2 Hr  | F Rating — 2 Hr   |
| Nominal Joint Width - 3/4 In.                                 | FT Rating — 2 Hr  |
| Class II Movement Capabilities — 33% Compression or Extension | FH Rating — 2 Hr)   |
| L Rating At Ambient — Less Than 1 CFM/lin ft                  | FTH Rating — 2 Hr   |
| L Rating At 400 F — Less Than 1 CFM/lin ft                    | Nominal Joint Width - 3/4 In.                                 |
|   | Class II Movement Capabilities — 33% Compression or Extension |
|   | L Rating At Ambient — Less Than 1 CFM/lin ft                  |
|   | L Rating At 400 F — Less Than 1 CFM/lin ft                    |

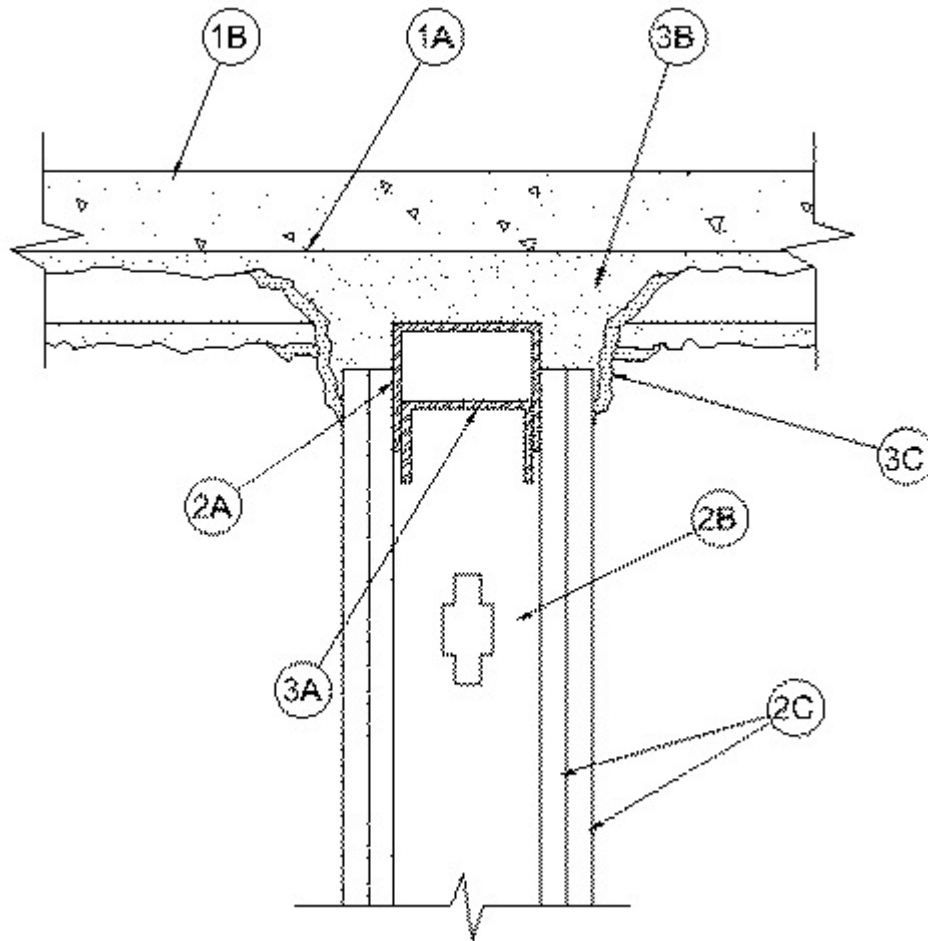

**1. Floor Assembly** — The fluted steel deck/concrete floor assembly shall be constructed of the materials and in the manner described in the individual Floor-Ceiling Design in the UL Fire Resistance Directory and shall include the following construction features:

A. **Steel Floor and Form Units\*** — Max 3 in. (76 mm) deep galv fluted units.

B. **Concrete** — Min 2-1/2 in. (64 mm) thick reinforced concrete, as measured from the top plane of the floor units.

C. **Spray-Applied Fire Resistive Material\*** — After the installation of the ceiling runner (Item 2A) or deflection channel (Item 3A), all surfaces of the steel floor units to be sprayed with the thickness of material specified in the individual D700 Series Design.

**GCP APPLIED TECHNOLOGIES INC** — Type MK-6/HY

**ISOLATEK INTERNATIONAL** — Type 300

**1A. Roof Assembly** — (**Not Shown**) As an alternate to the floor assembly, a fire-rated fluted steel deck roof assembly may be used. The roof assembly shall be constructed of the materials and in the manner described in the individual P700 Series Roof-Ceiling Design in the UL Fire Resistance Directory. The hourly rating of the roof assembly shall be equal to or greater than the hourly rating of the wall assembly.

A. **Steel Roof Deck** — Max 3 in. (76 mm) deep galv steel fluted roof deck.

B. **Roof Insulation** — As specified in the individual P700 Series Design.

C. **Spray - Applied Fire Resistive Materials** — After the installation of the ceiling runner (Item 2A) or deflection channel (Item 3A), the steel roof deck shall be sprayed with the thickness of material specified in the individual P700 Series Design.

**GCP APPLIED TECHNOLOGIES INC** — Type MK-6/HY

**ISOLATEK INTERNATIONAL** — Type 300

**2. Wall Assembly** — The 2 hr fire-rated gypsum board/steel stud wall assembly shall be constructed of the materials and in the manner described in the individual U400, V400 or W400 Series Wall or Partition Design in the UL Fire Resistance Directory. The wall assembly shall include the following construction features:

**A. Steel Floor and Ceiling Runners** — Floor and ceiling runners of wall assembly shall consist of galv steel channels sized to accommodate steel studs (Item 2B). When U-shaped deflection channel (Item 3A) is used, ceiling runner installed within the deflection channel with 3/4 to 1 in. (19 to 25 mm) gap maintained between the top of ceiling runner and top of deflection channel. When deflection channel is not used, ceiling runner installed perpendicular to direction of the fluted steel floor units or roof deck prior to the application of the spray-applied fire resistive material and secured with to valleys of fluted steel floor units or roof deck with steel fasteners or by welds spaced max 24 in. (610 mm) OC.

**A1. Light Gauge Framing\*** — When the thickness of spray-applied fire resistive material does not exceed 1 in. (25 mm), slotted ceiling runner maybe used as an alternate to the ceiling runner in Item 2A. Slotted ceiling runner to consist of galv steel channel with slotted flanges sized to accommodate steel studs (Item 2B). Slotted ceiling runner installed perpendicular to direction of fluted steel floor units or roof deck prior to the application of spray-applied fire resistive material and secured to valleys with steel fasteners spaced max 24 in. (610 mm) OC. When slotted ceiling runner is used deflection channel (Item 3A) shall not be used.

**BRADY CONSTRUCTION INNOVATIONS INC, DBA SLIPTRACK SYSTEMS** — SLP-TRK

**CALIFORNIA EXPANDED METAL PRODUCTS CO** — CST

**CLARKDIETRICH BUILDING SYSTEMS** — Type SLT, SLT-H

**MARINO/WARE, DIV OF WARE INDUSTRIES INC** — Type SLT

**METAL-LITE INC** — The System

**RAM SALES L L C** — RAM Slotted Track

**SCAFCO STEEL STUD MANUFACTURING CO**

**TELLING INDUSTRIES L L C** — True-Action Deflection Track

**A2. Light Gauge Framing\*-Vertical Deflection Ceiling Runner** — When the nom joint width is less than or equal to 3/4 in. (19 mm) and the thickness of spray-applied fire resistive material does not exceed 1 in. (25 mm), deflection ceiling runner may be used as an alternate to the ceiling runners in Items 2A and 2A1. Vertical deflection ceiling runner to consist of galv steel channel with slotted vertical deflection clips mechanically fastened within runner. Slotted clips provided with step bushings for permanent fastening of steel studs. Flanges sized to accommodate steel studs (Item 2B). Vertical deflection ceiling runner installed perpendicular to direction of fluted steel deck prior to the application of spray-applied fire resistive material and secured to valleys with steel fasteners spaced max 24 in. (610 mm) OC. When slotted ceiling runner is used deflection channel (Item 3A) shall not be used.

**THE STEEL NETWORK INC** — VertiTrack VTD362, VTD400, VTD600 and VTD800

**A3. Light Gauge Framing\* - Clipped Ceiling Runner** — When the thickness of spray-applied fire resistive material does not exceed 1 in., clipped ceiling runner may be used as an alternate to the ceiling runners in Items 2A, 2A1 and 2A2. Clipped runner to consist of galv steel channel with clips preformed in track flanges which positively engage the inside flange of the steel studs (Item 2B). Track sized to accommodate steel studs (Item 2B). Track flanges to be min 2-

1/2 in. (64 mm). Clipped ceiling runner installed perpendicular to direction of fluted steel floor units prior to the application of spray-applied fire resistive material and secured to valleys with steel fasteners spaced max 24 in. (610 mm) OC.

**TOTAL STEEL SOLUTIONS L L C** — Snap Trak

B. **Steel Studs** — Studs to be min 3-5/8 in. (92 mm) wide. Studs cut 1/2 to 3/4 in. (13 to 19 mm) less in length than assembly height. Studs attached to ceiling runner (Item 2A) with sheet metal screws a min of 1/2 in. (13 mm) below bottom of deflection channel (Item 3A), when deflection channel is used. When deflection channel is not used, studs shall not be secured to ceiling runner. When slotted ceiling runner is used, studs secured to slotted ceiling runner with No. 8 by 1/2 in. (13 mm) long wafer head steel screws at midheight of slot on each side of wall. When vertical deflection ceiling runner (Item 2A2) is used, steel studs secured to slotted vertical deflection clips, through the bushings, with steel screws at midheight of each slot. Stud spacing not to exceed 24 in. (610 mm) OC.

C. **Gypsum Board\*** — Gypsum board sheets installed to a min total thickness of 1-1/4 in. (32 mm) on each side of wall. Wall to be constructed as specified in the individual Wall and Partition Design in the UL Fire Resistance Directory, except that a nom 3/4 in. (19 mm) gap shall be maintained between the top of the gypsum board and the lower surface of the floor or roof deck. The screws attaching the gypsum board to studs (Item 2B) at the top of the wall shall be located 1 in. (25 mm) below the bottom of the ceiling runner (Item 2A, U-shaped), deflection channel (Item 3A) or slotted ceiling runner (Item 2A1).

3. **Joint System — Max separation between bottom of floor or roof deck and top of wall is 3/4 in. (19 mm). The joint system is designed to accommodate a max 33 percent compression or extension from its installed width.** The joint system is designed to accommodate a max 33 percent compression or extension from its installed width. The joint system consists of a deflection channel, forming material and a fill material as follows:

A. **Deflection Channel (Optional)** — Nom 3 in. (76 mm) deep by min 25 gauge galv steel U-shaped channel sized to accommodate ceiling runner (Item 2A). Deflection channel installed perpendicular to direction of the fluted steel floor units or roof deck prior to the application of the sprayed-applied fire resistive material and secured with steel fasteners or by welds spaced max 24 in. (610 mm) OC. The ceiling runner (Item 2A) is installed within the deflection channel to maintain a 3/4 to 1 in. (19 to 25 mm) gap between the top of the ceiling runner and the top of the deflection channel. The ceiling runner is not fastened to the deflection channel.

B. **Spray-Applied Fire Resistive Materials\*** — Min 3/4 in. (19 mm) thickness of spray-applied fire resistive materials applied to all surfaces of steel floor units or roof deck, within the entire joint system, overlapping onto gypsum board a min 1 in. (25 mm). Spray-applied fire resistive materials to form a radius of min 3 in. (76 mm) from steel floor units to joint system. The spray-applied fire resistive material is mixed with water in accordance with the mixing instructions on the bag and is sprayed and/or troweled to fill the flute above the wall. The minimum average density of the spray-applied fire resistive material shall be 15 pcf (240 kg/m<sup>3</sup>) with a minimum individual density of 14 pcf (224 kg/m<sup>3</sup>). See Design Information in Volume 1 of the Fire Resistance Directory for method of density determination.

**GCP APPLIED TECHNOLOGIES INC** — Type MK-6HY

**ISOLATEK INTERNATIONAL** — Type 300

C. **Fill, Void or Cavity Material\*** — Min 1/16 in. (1.6 mm) dry thickness (min 1/8 in. or 3.2 mm wet thickness) of fill material sprayed or brushed on each side of the joint system, completely covering radius formed from spray-applied fire resistive materials of the joint system and overlapping a min of 1/2 in. (13 mm) onto gypsum board (Item 2C) on both sides of wall.

**HILTI CONSTRUCTION CHEMICALS, DIV OF HILTI INC** — CP 672 Firestop Spray or CFS-SP WB Firestop Joint Spray

**\* Indicates such products shall bear the UL or cUL Certification Mark for jurisdictions employing the UL or cUL Certification (such as Canada), respectively.**

The appearance of a company's name or product in this database does not in itself assure that products so identified have been manufactured under UL's Follow-Up Service. Only those products bearing the UL Mark should be considered to be Certified and covered under UL's Follow-Up Service. Always look for the Mark on the product.

UL permits the reproduction of the material contained in the Online Certification Directory subject to the following conditions: 1. The Guide Information, Assemblies, Constructions, Designs, Systems, and/or Certifications (files) must be presented in their entirety and in a non-misleading manner, without any manipulation of the data (or drawings). 2. The statement "Reprinted from the Online Certifications Directory with permission from UL" must appear adjacent to the extracted material. In addition, the reprinted material must include a copyright notice in the following format: "© 2020 UL LLC"