



# XHBN.HW-D-0283 - Joint Systems

## Design/System/Construction/Assembly Usage Disclaimer

- Authorities Having Jurisdiction should be consulted in all cases as to the particular requirements covering the installation and use of UL Certified products, equipment, system, devices, and materials.
- Authorities Having Jurisdiction should be consulted before construction.
- Fire resistance assemblies and products are developed by the design submitter and have been investigated by UL for compliance with applicable requirements. The published information cannot always address every construction nuance encountered in the field.
- When field issues arise, it is recommended the first contact for assistance be the technical service staff provided by the product manufacturer noted for the design. Users of fire resistance assemblies are advised to consult the general Guide Information for each product category and each group of assemblies. The Guide Information includes specifics concerning alternate materials and alternate methods of construction.
- Only products which bear UL's Mark are considered Certified.

---

## XHBN - Joint Systems

See General Information for Joint Systems

### **System No. HW-D-0283**

June 27, 2011

**Assembly Rating — 1 and 2 Hr (See Item 2)**

**Nominal Joint Width — 1 In.**

**Class II and III Movement Capabilities — 20% Compression Or Extension**

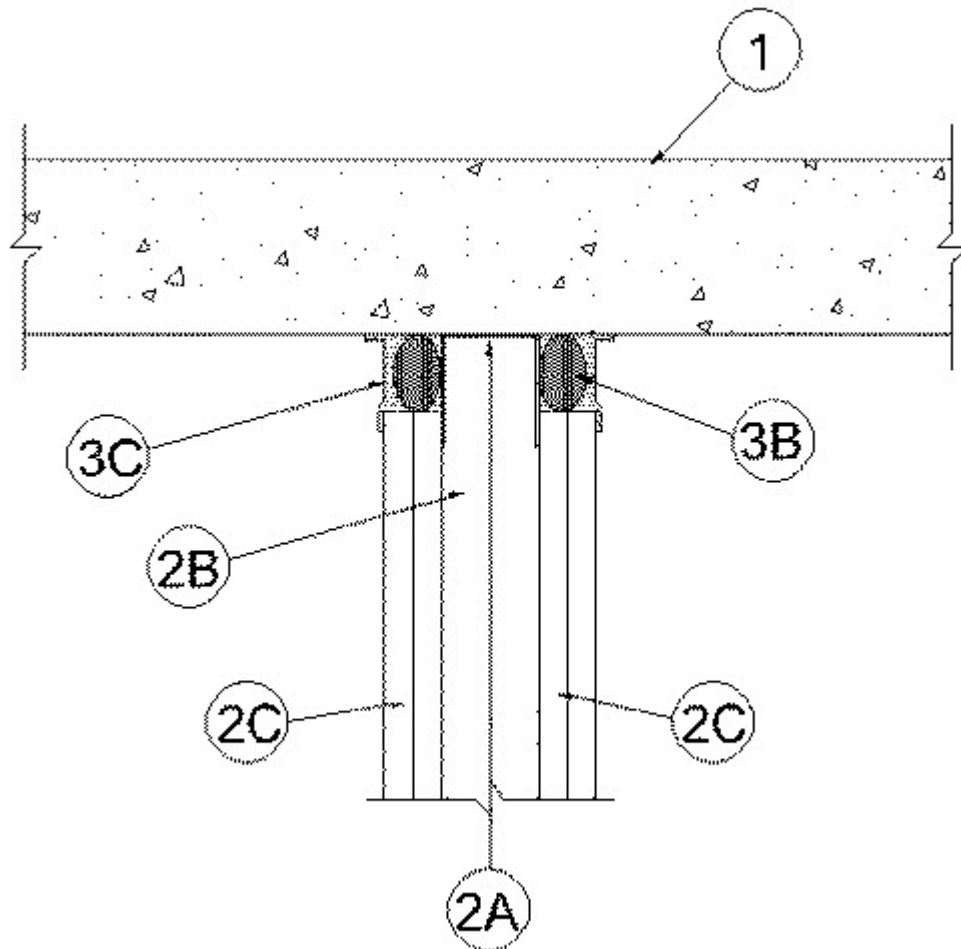

1. **Floor Assembly** — Min 5-1/2 in. thick reinforced light weight or normal weight (100-150 pcf) structural concrete.

2. **Wall Assembly** — The 1 or 2 hr fire rated gypsum board/steel stud wall assembly shall be constructed of the materials and in the manner described in the individual U400-Series Wall or Partition Design in the UL Fire Resistance Directory and shall include the following construction features:

A. **Steel Floor and Ceiling Runners** — Floor and ceiling runners of wall assembly shall consist of galv steel channels sized to accommodate steel studs (Item 2B). Ceiling runner to be provided with 2 in. flange. When U-shaped deflection channel (Item 3A) is used, ceiling runner is installed within the U-shaped deflection channel with a 5/8 in gap maintained between the top of the ceiling runner and the top of the deflection channel. When deflection channel is not used, ceiling runner is secured to floor with steel fasteners spaced max 24 in. OC.

A1. **Light Gauge Framing\*** — Slotted Ceiling Runner - As an alternative to the ceiling runner in Item 2A, slotted ceiling runner to consist of galv steel channel with slotted flanges sized to accommodate steel studs (Item 2B). Slotted ceiling runner secured to concrete floor with steel fasteners spaced max 24 in. OC. When slotted ceiling runner is used, deflection channel (Item 3A) shall not be used.

**BRADY CONSTRUCTION INNOVATIONS INC, DBA SLIPTRACK SYSTEMS** — SLP-TRK

**MARINO/WARE, DIV OF WARE INDUSTRIES INC** — Type SLT

A2. **Light Gauge Framing\*** — Clipped Ceiling Runner As an alternate to the ceiling runner in Items 2A and 2A1, clipped runner to consist of galv steel channel with clips preformed in track flanges which positively engage the inside flange of the steel studs (Item 2B). Track sized to accommodate steel studs (Item 2B). Track flanges to be min 2-1/2 in. Clipped ceiling runner installed to concrete floor (Item 1) with steel masonry anchors spaced max 24 in. OC. When clipped ceiling runner is used, deflection channel (Item 3A) shall not be used.

**CALIFORNIA EXPANDED METAL PRODUCTS CO** — CST

**TOTAL STEEL SOLUTIONS L L C** — Snap Trak

**B. Studs** — Steel studs to be min 3-1/2 in. wide. Studs cut 5/8 in. less in length than assembly height with bottom nesting in and resting on floor runner and with top nesting in ceiling runner. Studs secured to floor runners with sheet metal screw. When deflection channel is used, studs are attached to ceiling runners with sheet metal screws a min. 1/2 in. above the bottom of deflection channel. When deflection channel is not used, studs shall not be attached to ceiling runner. When slotted ceiling runner (Item 2A1) is used, steel studs secured to slotted ceiling runner with No. 8 x 1/2 in. long wafer head steel screws at midheight of slot on each side of wall. Stud spacing not to exceed 24 in. OC.

**C. Gypsum Board\*** — Gypsum board sheets installed to a min total thickness of 5/8 in. or 1-1/4 in. on each side of wall for 1 or 2 hr fire rated assemblies, respectively. Wall to be constructed as specified in the individual Wall and Partition Design in the UL Fire Resistance Directory, except that a nom 1 in. gap shall be maintained between the top of the gypsum board and the bottom of floor. The top row of screws shall be installed into the studs 3 in. below the top edge of the gypsum board.

**3. Joint System** — Max separation between bottom of floor and top of wall at time of installation of joint system is 1 in. The joint system is designed to accommodate a max 20 percent compression or extension from its installed width. The joint system consists of a packing material and a fill material, with or without a deflection channel, as follows:

**A. Deflection Channel (Optional)** — A nom 3-1/2 in. wide by min 2 in. deep, min 24 galv steel U-shaped channel. Deflection channel secured to floor with steel fasteners spaced max 24 in. OC. The ceiling runner (Item 2A) is installed within the deflection channel to maintain a 5/8 in. gap between the top of the ceiling runner and the top of the deflection channel. The ceiling runner is not fastened to the deflection channel.

**B. Packing Material\*** — Foam backer rod firmly packed into gap between top of gypsum board and bottom of concrete floor as a permanent form. Forming material is to be recessed from each surface of wall to accommodate the required thickness of fill material.

**C. Fill, Void or Cavity Material\*** — Min 1/4 in. wet thickness of fill material sprayed or troweled on each side of the wall to completely cover packing material and to overlap a min of 1/2 in. onto wall and floor on both sides of wall.

**EGS NELSON FIRESTOP** — LBS+

**\* Indicates such products shall bear the UL or cUL Certification Mark for jurisdictions employing the UL or cUL Certification (such as Canada), respectively.**

Last Updated on 2011-06-27

---

The appearance of a company's name or product in this database does not in itself assure that products so identified have been manufactured under UL's Follow-Up Service. Only those products bearing the UL Mark should be considered to be Certified and covered under UL's Follow-Up Service. Always look for the Mark on the product.

UL permits the reproduction of the material contained in the Online Certification Directory subject to the following conditions: 1. The Guide Information, Assemblies, Constructions, Designs, Systems, and/or Certifications (files) must be presented in their entirety and in a non-misleading manner, without any manipulation of the data (or drawings). 2. The statement "Reprinted from the Online Certifications Directory with permission from UL" must appear adjacent to the extracted material. In addition, the reprinted material must include a copyright notice in the following format: "© 2020 UL LLC"