



XHBN.HW-D-0160 - Joint Systems

Design/System/Construction/Assembly Usage Disclaimer

- Authorities Having Jurisdiction should be consulted in all cases as to the particular requirements covering the installation and use of UL Certified products, equipment, system, devices, and materials.
- Authorities Having Jurisdiction should be consulted before construction.
- Fire resistance assemblies and products are developed by the design submitter and have been investigated by UL for compliance with applicable requirements. The published information cannot always address every construction nuance encountered in the field.
- When field issues arise, it is recommended the first contact for assistance be the technical service staff provided by the product manufacturer noted for the design. Users of fire resistance assemblies are advised to consult the general Guide Information for each product category and each group of assemblies. The Guide Information includes specifics concerning alternate materials and alternate methods of construction.
- Only products which bear UL's Mark are considered Certified.

XHBN - Joint Systems

XHBN7 - Joint Systems Certified for Canada

See General Information for Joint Systems

See General Information for Joint Systems Certified for Canada

System No. HW-D-0160

December 27, 2019

ANSI/UL2079	CAN/ULC S115
Assembly Ratings — 1 and 2 Hr (See Item 2)	F Ratings — 1 and 2 Hr (See Item 2)
Nominal Joint Width - 1 In.	FT Ratings — 1 and 2 Hr (See Item 2)
Class II or III Movement Capabilities — 25% Compression or Extension	FH Ratings — 1 and 2 Hr (See Item 2)
	FTH Ratings — 1 and 2 Hr (See Item 2)
	Nominal Joint Width - 25 mm.
	Class II or III Movement Capabilities — 25% Compression or Extension

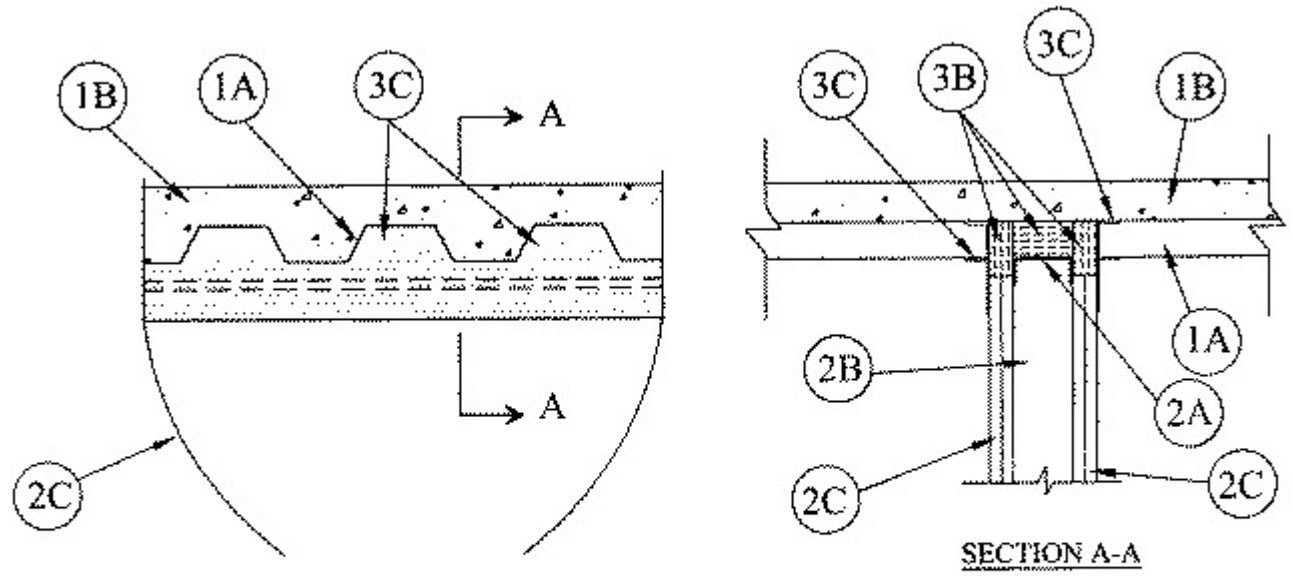

CONFIGURATION A

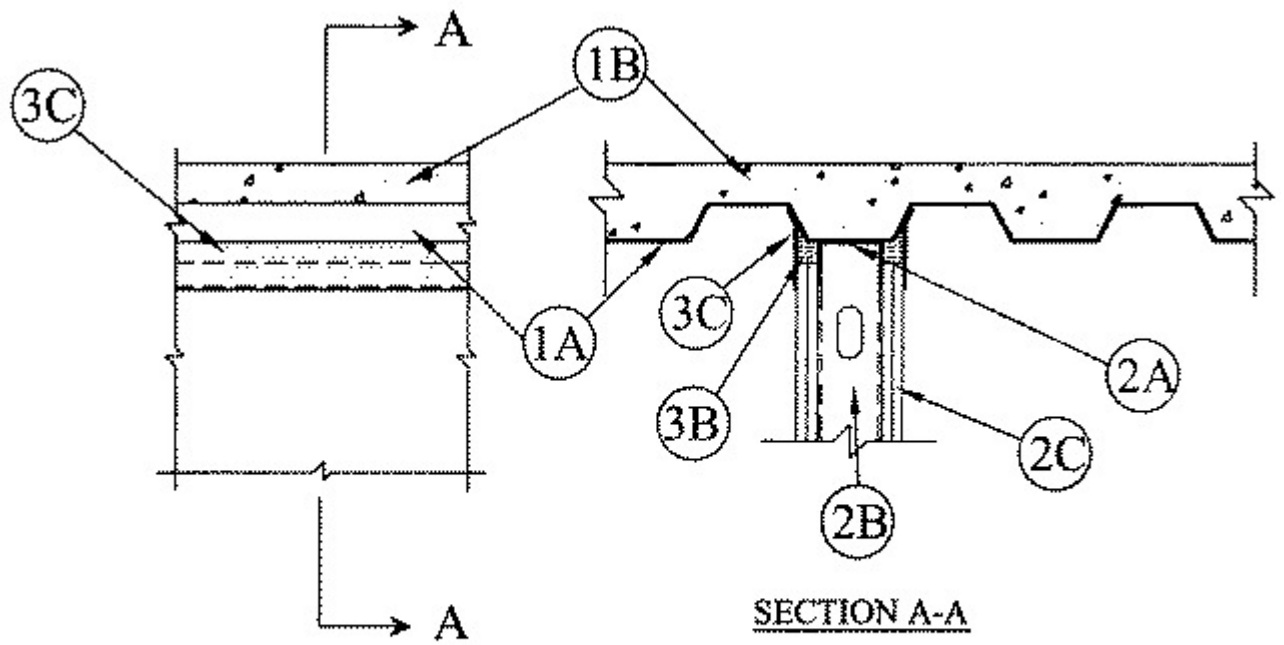

CONFIGURATION B

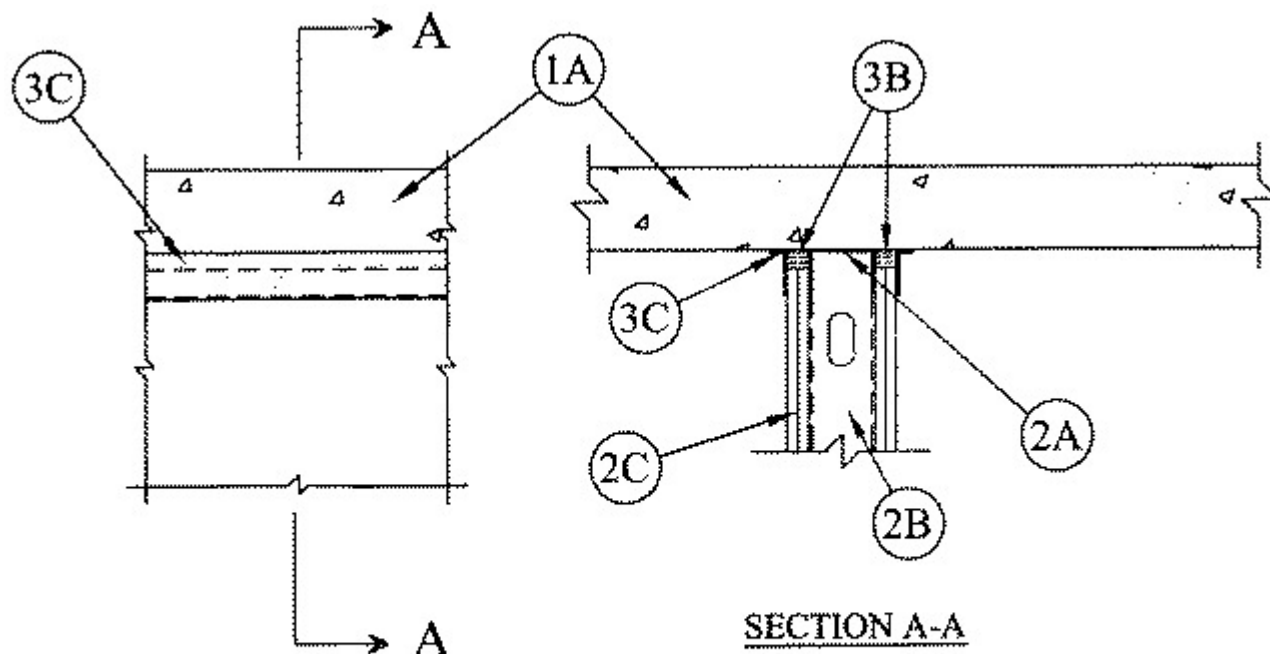

CONFIGURATION C

1. Floor Assembly — The fire-rated fluted steel deck/concrete floor assembly shall be constructed of the materials and in the manner described in the individual P900 Series Floor-Ceiling Design in the UL Fire Resistance Directory and shall include the following construction features:

A. **Steel Floor and Form Units*** — Max 3 in. (76 mm) deep galv steel fluted units.

B. **Concrete** — Min 2-1/2 in. (64 mm) thick reinforced concrete, as measured from the top plane of the floor units.

1A. **Floor Assembly** — As an alternate to Item 1, min 4-1/2 in. (114 mm) thick reinforced lightweight or normal weight (100-150 pcf or 1600-2400 kg/m³) structural concrete.

2. Wall Assembly — The 1 or 2 hr fire rated gypsum board/steel stud wall assembly shall be constructed of the materials and in the manner described in the individual U400- or V400 Series Wall or Partition Design in the UL Fire Resistance Directory and shall include the following construction features:

A. **Steel Floor and Ceiling Runners** — Floor and ceiling runners of wall assembly shall consist of galv steel channels sized to accommodate steel studs (Item 2B). Ceiling runner to be provided with min 1-1/4 in. (32 mm) flanges. When U-shaped deflection channel (Item 3A) is used, ceiling runner installed within the deflection channel with 1 in. (25 mm) gap maintained between the top of ceiling runner and top of deflection channel. When deflection channel is not used, ceiling runner to be provided with min. 1-1/2 in. (38 mm) flanges. Ceiling runner is secured to the bottom of the floor with steel fasteners spaced max 24 in. (610 mm) OC or to the valleys of steel floor units (Item 1A) with steel fasteners or by welds spaced max 24 in. (610 mm) OC.

A1. **Light Gauge Framing* — Slotted Ceiling Runner** — As an alternate to the ceiling runner in Item 2A, slotted ceiling runner to consist of galv steel channel with slotted flanges sized to accommodate steel studs (Item 2B). Slotted ceiling runner is secured to bottom of floor with steel fasteners spaced 24 in. (610 mm) OC or to steel floor units (Item 1A) with steel fasteners or by welds spaced max 24 in. (610 mm) OC.

BRADY CONSTRUCTION INNOVATIONS INC, DBA SLIPTRACK SYSTEMS — SLP-TRK

CALIFORNIA EXPANDED METAL PRODUCTS CO — CST

CONSOLIDATED FABRICATORS CORP, BUILDING PRODUCTS DIV — SDT250, SDT300

OLMAR SUPPLY INC — STT250, STT300

R & P SUPPLY — SCT250, SCT300

SCAFCO STEEL STUD MANUFACTURING CO

TELLING INDUSTRIES L L C — True-Action Deflection Track

A2. Light Gauge Framing* - Vertical Deflection Ceiling Runner — When the nom joint width is less than or equal to 3/4 in. (19 mm) vertical deflection ceiling runner may be used as an alternate to the ceiling runners in Items 2A and 2A1. Vertical deflection ceiling runner to consist of galv steel channel with slotted vertical deflection clips mechanically fastened within runner. Slotted clips provided with step bushings for permanent fastening of steel studs. Flanges sized to accommodate steel studs (Item 2B). Vertical deflection ceiling runner secured to bottom of floor with steel fasteners spaced 24 in. (610 mm) OC or to steel floor units (Item 1A) with steel fasteners or by welds spaced max 24 in. (610 mm) OC.

THE STEEL NETWORK INC — VertiTrack VTD250, VTD362, VTD400, VTD600 and VTD800

B. Studs — Steel studs to be min 3-5/8 in. (92 mm) wide. Studs cut 1/2 to 3/4 in. (13 to 19 mm) less in length than assembly height with bottom nesting in, resting on and attached to the floor runner with sheet metal screws. The top of the studs shall be nesting in ceiling runner without attachment. When slotted ceiling runner (Item 2A1) is used, steel studs secured to slotted ceiling runner with No. 8 by 1/2 in. (13 mm) long wafer head steel screws at midheight of slot on each side of wall. When vertical deflection ceiling runner (Item 2A2) is used, steel studs secured to slotted vertical deflection clips, through the bushings, with steel screws at midheight of each slot. Stud spacing not to exceed 24 in. (610 mm) OC.

C. Gypsum Board* — Gypsum board sheets installed to a min total thickness of 5/8 in. (16 mm) and 1-1/4 in. (32 mm) on each side of wall for 1 and 2 hr rated assemblies, respectively. Wall to be constructed as specified in the individual Wall and Partition Design in the UL Fire Resistance Directory, except that a nom 1 in. (25 mm) gap shall be maintained between the top of the gypsum board and the bottom of the steel floor units and the top row of screws shall be installed into the studs 3-1/2 in. (89 mm) below the lower surface the floor.

The hourly fire rating of the joint system is equal to the hourly fire rating of the wall.

3. Joint System — Max separation between bottom of floor and top of wall is 1 in. (19 mm). The joint system is designed to accommodate a max 25 percent compression or extension from its installed width. The joint system consists of the following:

Joint Configuration A

A. Deflection Channel — (Optional, Not Shown) - A min 3 in. (76 mm) deep by min 24 ga steel U-shaped channel sized to accommodate the ceiling runner (Item 2A). Deflection channel secured to valleys of steel floor units (Item 1A) with steel fasteners or by welds spaced max 24 in. (610 mm) OC. The ceiling runner (Item 2A) is installed within the deflection channel to maintain a 1 in. (25 mm) gap between the top of the ceiling runner and the top of the deflection channel. The ceiling runner is not fastened to the deflection channel.

B. Forming Material* — Min 4 pcf (64 kg/m³) density mineral wool batt insulation cut approx 50 percent wider than the flutes, approx 50 percent thicker than the depth of the steel deck, and with a length equal to the overall width of the wall. Mineral wool compressed and inserted into flutes of the steel floor units between top of ceiling runner and the steel deck. Additional pieces of min 4 pcf (64 kg/m³) mineral wool batt insulation having a thickness equal to the overall thickness of the gypsum board (Item 2C) are to be cut to 1 in. (25 mm) larger than the opening height and inserted into the opening on both sides of the wall.

INDUSTRIAL INSULATION GROUP L L C — MinWool-1200 Safing

JOHNS MANVILLE — Safing

ROCK WOOL MANUFACTURING CO — Delta Board

ROCKWOOL MALAYSIA SDN BHD — Type Safe

ROCKWOOL — Type Safe

THERMAFIBER INC — Type SAF

B1. Forming Material* — (Optional, Not Shown) - Preformed mineral wool plugs, formed to the shape of the fluted floor units, friction fit to completely fill the flutes above the ceiling channel. The plugs shall project beyond each side of the ceiling runner and shall be recessed from both wall surfaces to accommodate the required thickness of fill material (Item 3C). Additional forming material, described in Item 3B, to be used in conjunction with the plugs to fill the gap between the top of gypsum board and bottom of steel deck.

THERMAFIBER INC — TopStop mineral wool deck plugs Type SAF batts

C. Fill, Void or Cavity Material* — Min 1/8 in. (3.2 mm) dry thickness of fill material sprayed or brushed on each side of the wall to completely cover mineral wool and overlap a min of 1/2 in. (13 mm) onto wallboard gypsum board and steel deck.

UNITED STATES GYPSUM CO — Type SA

Joint Configuration B

A. Deflection Channel — (Optional, Not Shown) - A min 3 in. (76 mm) deep by min 24 ga steel U-shaped channel centered on valleys of steel floor units (Item 1A) and sized to accommodate the ceiling runner (Item 2A). Deflection channel secured to valleys of steel floor units (Item 1A) with steel fasteners or by welds spaced max 24 in. (610 mm) OC. The ceiling runner (Item 2A) is installed within the deflection channel to maintain a 1 in. (25 mm) gap between the top of the ceiling runner and the top of the deflection channel. The ceiling runner is not fastened to the deflection channel.

B. Forming Material* — Min 4 pcf (64 kg/m³) density mineral wool batt insulation cut to a thickness equal to the overall thickness of the gypsum board and compressed 50 percent in height and inserted between the top of the gypsum board and the steel deck on both sides of the wall.

INDUSTRIAL INSULATION GROUP L L C — MinWool-1200 Safing

JOHNS MANVILLE — Safing

ROCK WOOL MANUFACTURING CO — Delta Board

ROCKWOOL MALAYSIA SDN BHD — Type Safe

ROCKWOOL — Type Safe

THERMAFIBER INC — Type SAF

C. Fill, Void or Cavity Material* — Min 1/8 in. (3.2 mm) dry thickness of fill material sprayed or brushed on each side of the wall to completely cover mineral wool and overlap a min of 1/2 in. (13 mm) onto wall and steel deck.

UNITED STATES GYPSUM CO — Type SA

Joint Configuration C

A. Deflection Channel — (Optional, Not Shown) - A min 3 in. (76 mm) deep by min 24 ga steel U-shaped channel and sized to accommodate the ceiling runner (Item 2A). Deflection channel secured to bottom of floor with steel fasteners spaced max 24 in. (610 mm) OC. The ceiling runner (Item 2A) is installed within the deflection channel to maintain a 1 in. (25 mm) gap between the top of the ceiling runner and the top of the deflection channel. The ceiling runner is not fastened to the deflection channel.

B. Forming Material* — Min 4 pcf (64 kg/m³) density mineral wool batt insulation cut to a thickness equal to the overall thickness of the gypsum board and compressed 50 percent in height and inserted between the top of the gypsum board and bottom of floor on both sides of the wall.

INDUSTRIAL INSULATION GROUP L L C — MinWool-1200 Safing

JOHNS MANVILLE — Safing

ROCK WOOL MANUFACTURING CO — Delta Board

ROCKWOOL MALAYSIA SDN BHD — Type Safe

ROCKWOOL — Type Safe

THERMAFIBER INC — Type SAF

C. Fill, Void or Cavity Material* — Min 1/8 in. (3.2 mm) dry thickness of fill material sprayed or brushed on each side of the wall to completely cover mineral wool and overlap a min of 1/2 in. (13 mm) onto wall and floor.

UNITED STATES GYPSUM CO — Type SA

*** Indicates such products shall bear the UL or cUL Certification Mark for jurisdictions employing the UL or cUL Certification (such as Canada), respectively.**

Last Updated on 2019-12-27

The appearance of a company's name or product in this database does not in itself assure that products so identified have been manufactured under UL's Follow-Up Service. Only those products bearing the UL Mark should be considered to be Certified and covered under UL's Follow-Up Service. Always look for the Mark on the product.

UL permits the reproduction of the material contained in the Online Certification Directory subject to the following conditions: 1. The Guide Information, Assemblies, Constructions, Designs, Systems, and/or Certifications (files) must be presented in their entirety and in a non-misleading manner, without any manipulation of the data (or drawings). 2. The statement "Reprinted from the Online Certifications Directory with permission from UL" must appear adjacent to the extracted material. In addition, the reprinted material must include a copyright notice in the following format: "© 2020 UL LLC"