



XHBN.HW-D-0101 - Joint Systems

Design/System/Construction/Assembly Usage Disclaimer

- Authorities Having Jurisdiction should be consulted in all cases as to the particular requirements covering the installation and use of UL Certified products, equipment, system, devices, and materials.
- Authorities Having Jurisdiction should be consulted before construction.
- Fire resistance assemblies and products are developed by the design submitter and have been investigated by UL for compliance with applicable requirements. The published information cannot always address every construction nuance encountered in the field.
- When field issues arise, it is recommended the first contact for assistance be the technical service staff provided by the product manufacturer noted for the design. Users of fire resistance assemblies are advised to consult the general Guide Information for each product category and each group of assemblies. The Guide Information includes specifics concerning alternate materials and alternate methods of construction.
- Only products which bear UL's Mark are considered Certified.

XHBN - Joint Systems

XHBN7 - Joint Systems Certified for Canada

See General Information for Joint Systems

See General Information for Joint Systems Certified for Canada

System No. HW-D-0101

December 27, 2019

ANSI/UL2079	CAN/ULC S115
Assembly Ratings — 1 and 2 Hr (See Item 2)	F Ratings — 1 and 2 Hr (See Item 2)
Nominal Joint Width - 1 In.	FT Ratings — 1 and 2 Hr (See Item 2)
Class II Movement Capabilities — 25% Compression or Extension	FH Ratings— 1 and 2 Hr (See Item 2B)
L Rating At Ambient — Less Than 1 CFM/Lin Ft	FTH Ratings — 1 and 2 Hr (See Item 2)
L Rating At 400 F — Less Than 1 CFM/Lin Ft	Nominal Joint Width - 25 mm
	Class II Movement Capabilities — 25% Compression or Extension
	L Rating at Ambient — Less than 1.55 L/s/lin m
	L Rating at 204°C — Less than 1.55 L/s/lin m

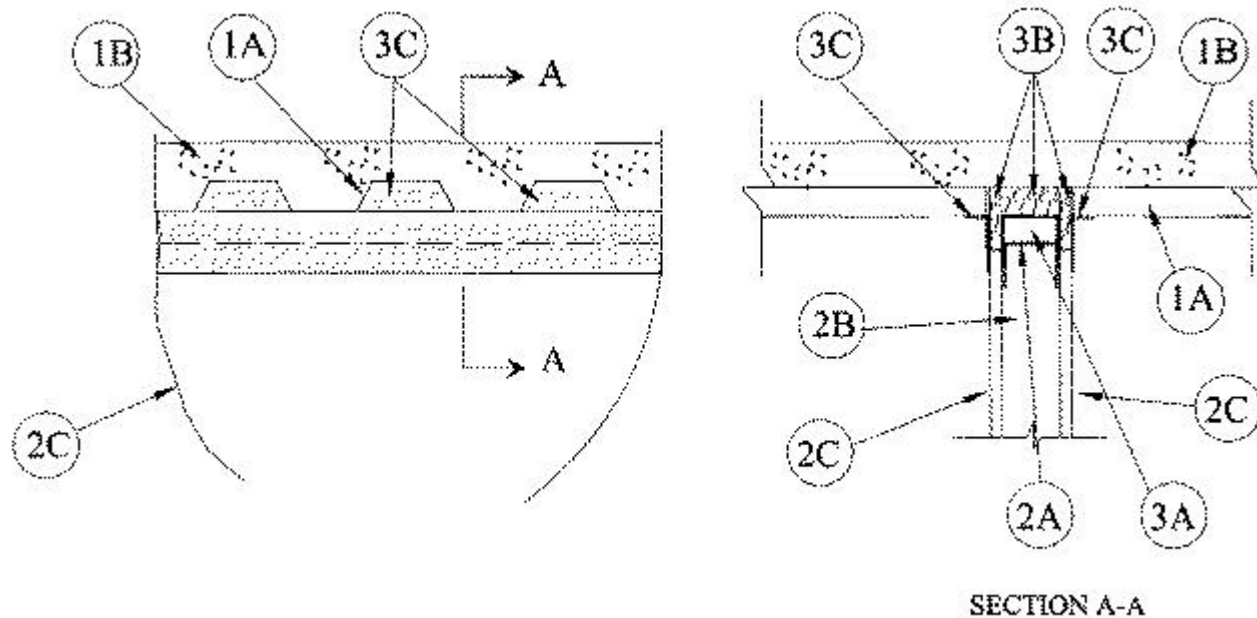

1. **Floor Assembly** — The fire-rated fluted steel deck/concrete floor assembly shall be constructed of the materials and in the manner described in the individual Floor-Ceiling Design in the UL Fire Resistance Directory and shall include the following construction features:

A. **Steel Floor and Form Units*** — Max 3 in. (76 mm) deep galv steel fluted units.

B. **Concrete** — Min 2-1/2 in. (64 mm) thick reinforced concrete, as measured from the top plane of the floor units.

2. **Wall Assembly** — The 1 hr or 2 fire rated gypsum board/steel stud wall assembly shall be constructed of the materials and in the manner described in the individual U400 or V400 Series Wall and Partition Designs in the UL Fire Resistance Directory and shall include the following construction features:

A. **Steel Floor and Ceiling Runners** — Floor and ceiling runners of wall assembly shall consist of galv steel channels sized to accommodate steel studs (Item 2B). When deflection channel (Item 3A) is used, ceiling runner to be installed within the deflection channel with 1 in. (25 mm) gap maintained between the top of ceiling runner and top of deflection channel. When deflection channel is not used, flange height of ceiling runner shall be min 3/4 in. (19 mm) greater than nom joint width. Ceiling runner installed perpendicular to direction of fluted steel deck and secured with steel masonry anchors or by welds spaced max 24 in. (610 mm) OC.

A1. **Light Gauge Framing*** — **Slotted Ceiling Runner** — As an alternate to the ceiling runner in Item 2A, slotted ceiling runner to consist of galv steel channel with slotted flanges sized to accommodate steel studs (Item 2B). Slotted ceiling runner installed perpendicular to direction of fluted steel deck and secured to valleys with steel masonry anchors spaced max 24 in. (610 mm) OC. When slotted ceiling runner is used, deflection channel (Item 3A) shall not be used.

BRADY CONSTRUCTION INNOVATIONS INC, DBA SLIPTRACK SYSTEMS — SLP-TRK

CALIFORNIA EXPANDED METAL PRODUCTS CO — CST

CLARKDIETRICH BUILDING SYSTEMS — Type SLT, SLT-H

MARINO/WARE, DIV OF WARE INDUSTRIES INC — Type SLT

METAL-LITE INC — The System

RAM SALES L L C — RAM Slotted Track

SCAFCO STEEL STUD MANUFACTURING CO

TELLING INDUSTRIES L L C — True-Action Deflection Track

A2. Light Gauge Framing* — Notched Ceiling Runner — As an alternate to the ceiling runners in Items 2A through 2A2, notched ceiling runners to consist of C-shaped galv steel channel with notched return flanges sized to accommodate steel studs (Item 2B). Notched ceiling runner installed perpendicular to direction of fluted steel deck and secured to valleys with steel masonry anchors spaced max 24 in. (610 mm) OC. When notched ceiling runner is used, deflection channel (Item 3A) shall not be used.

OLMAR SUPPLY INC — Type SCR

B. Studs — Steel studs to be min 3-1/2 in. (89 mm) wide. Studs cut 1/2 to 3/4 in. (13 to 19 mm) less in length than assembly height with bottom nesting in and resting on floor runner and with top nesting in ceiling runner without attachment. When slotted ceiling runner (Item 2A1) is used, steel studs secured to slotted ceiling runner with No. 8 by 1/2 in. (13 mm) long wafer head steel screws at midheight of slot on each side of wall. Stud spacing not to exceed 24 in. (610 mm) OC.

C. Gypsum Board* — Gypsum board sheets installed to a min total thickness of 5/8 in. (16 mm) and 1-1/4 in. (32 mm) on each side of wall for 1 and 2 hr rated assemblies, respectively. Wall to be constructed as specified in the individual Wall and Partition Design in the UL Fire Resistance Directory, except that a nom 1 in. (25 mm) gap shall be maintained between the top of the gypsum board and the bottom of the steel floor units and the top row of screws shall be installed into the studs 3-1/2 in. (89 mm) below the lower surface of the floor. The hourly fire rating of the joint system is equal to the hourly fire rating of the wall.

3. Joint System — Max separation between bottom of floor and top of wall is 1 in. (25 mm). The joint system is designed to accommodate a max 25 percent compression or extension from its installed width. The joint system consists of a deflection channel, forming material and a fill material, as follows:

A. Deflection Channel — (Optional)— A nom 3-5/8 in. (92 mm) wide by 3 in. (76 mm) deep min 24 ga steel U-shaped channel. Flange height of deflection channel shall be min 3/4 in. (19 mm) greater than nom joint width. Deflection channel installed perpendicular to direction of fluted steel deck and secured to valleys with steel masonry anchors or by welds spaced max 24 in. (610 mm) OC. The ceiling runner (Item 2A) is installed within the deflection channel to maintain a 1 in. (25 mm) gap between the top of the ceiling runner and the top of the deflection channel. The ceiling runner is not fastened to the deflection channel.

B. Forming Material* — Min 4 in. (102 mm) thickness of min 4 pcf (64 kg/m³) density mineral wool batt insulation cut to the shape of the fluted deck, approx 20 percent larger than the area of the flutes and compressed into flutes of the steel floor units between the top of the deflection channel and the steel deck. Additional pieces of min 4 pcf (64 kg/m³) mineral wool batt insulation are to be cut to the contour of the flutes with an additional 1-3/8 in. (35 mm) high section at the bottom of the shapes to fill the 1 in. (25 mm) gap between the top of the gypsum board and the bottom of the steel floor units. The additional pieces of mineral wool are compressed and firmly packed into the flutes and the gap between the top of the gypsum board and the bottom of the steel floor units on both sides of the wall. The additional pieces shall be a 3/4 in. (19 mm) thick for a 1 hr rated design and a 1-1/2 in. (38 mm) thick for a 2 hr rated design.

INDUSTRIAL INSULATION GROUP L L C — MinWool-1200 Safing

JOHNS MANVILLE — Safing

ROCK WOOL MANUFACTURING CO — Delta Board or Delta-8

ROCKWOOL MALAYSIA SDN BHD — Type Safe

ROCKWOOL — Type Safe

THERMAFIBER INC — Type SAF

C. Fill, Void or Cavity Material* — Min 1/16 in. dry, (1/8 in. wet) thickness of fill material sprayed or brushed on each side of the wall in the flutes of the steel floor units and between the top of the gypsum board and the bottom of the steel floor units to completely cover mineral wool and overlap a min of 1/2 in. onto gypsum board and steel deck on both sides of wall.

3M COMPANY — Firedam™ Spray 200

C1. Fill, Void or Cavity Material* - Tape — As an alternate to Item C, Tape cut to size and press applied within fluted areas of joint to completely cover mineral wool lapping min 1 in. (25 mm) onto the contour of the steel floor units and extending to lap min 1 in. (25 mm) onto the gypsum board. Additional pieces of Tape are applied along the joint to completely cover the remaining mineral wool between bottom of steel deck and top edge of gypsum board along length of joint, lapping min 1 in. (25 mm) onto the steel floor units and gypsum board. Adjoining lengths of Tape shall overlap min 1/2 in. (13 mm). Tape shall be applied at both sides of wall.

3M COMPANY — 3M Fire and Water Barrier Tape

*** Indicates such products shall bear the UL or cUL Certification Mark for jurisdictions employing the UL or cUL Certification (such as Canada), respectively.**

Last Updated on 2019-12-27

The appearance of a company's name or product in this database does not in itself assure that products so identified have been manufactured under UL's Follow-Up Service. Only those products bearing the UL Mark should be considered to be Certified and covered under UL's Follow-Up Service. Always look for the Mark on the product.

UL permits the reproduction of the material contained in the Online Certification Directory subject to the following conditions: 1. The Guide Information, Assemblies, Constructions, Designs, Systems, and/or Certifications (files) must be presented in their entirety and in a non-misleading manner, without any manipulation of the data (or drawings). 2. The statement "Reprinted from the Online Certifications Directory with permission from UL" must appear adjacent to the extracted material. In addition, the reprinted material must include a copyright notice in the following format: "© 2020 UL LLC"