



# XHBN.HW-D-0062 - Joint Systems

## Design/System/Construction/Assembly Usage Disclaimer

- Authorities Having Jurisdiction should be consulted in all cases as to the particular requirements covering the installation and use of UL Certified products, equipment, system, devices, and materials.
- Authorities Having Jurisdiction should be consulted before construction.
- Fire resistance assemblies and products are developed by the design submitter and have been investigated by UL for compliance with applicable requirements. The published information cannot always address every construction nuance encountered in the field.
- When field issues arise, it is recommended the first contact for assistance be the technical service staff provided by the product manufacturer noted for the design. Users of fire resistance assemblies are advised to consult the general Guide Information for each product category and each group of assemblies. The Guide Information includes specifics concerning alternate materials and alternate methods of construction.
- Only products which bear UL's Mark are considered Certified.

## XHBN - Joint Systems

See General Information for Joint Systems

### **System No. HW-D-0062**

December 26, 2019

**Assembly Ratings — 1, 2, 3 and 4 Hr (See Item 2)**

**L Rating At Ambient — Less Than 1 CFM/Lin Ft.**

**L Rating At 400 F — Less Than 1 CFM/Lin Ft.**

**Nominal Joint Width — 3/4 In.**

**Class II Movement Capabilities — 33% Compression & Extension**

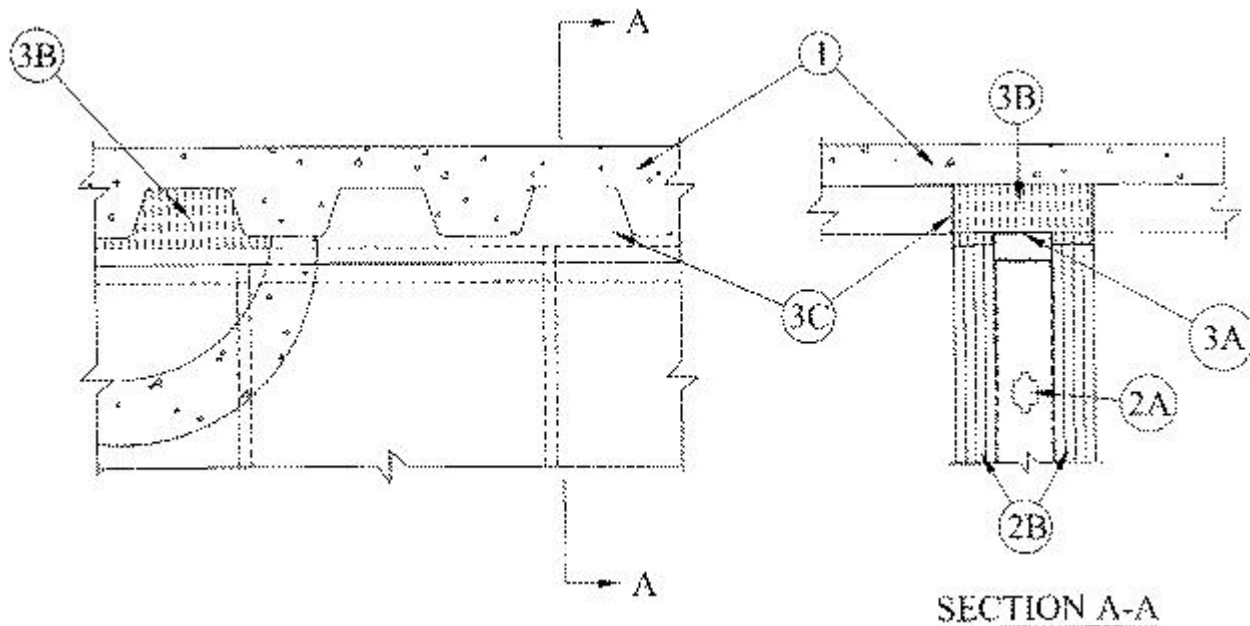

1. **Floor Assembly** — The fluted steel deck/concrete floor assembly shall be constructed of the materials and in the manner described in the individual Floor-Ceiling Design in the UL Fire Resistance Directory and shall include the following construction features:

A. **Steel Floor and Form Units\*** — Max 3 in. (76 mm) deep galv fluted units.

B. **Concrete** — Min 2-1/2 in. (64 mm) thick reinforced concrete, as measured from the top plane of the floor units.

1A. **Roof Assembly — (Not Shown)** — As an alternate to the floor assembly, a fire rated fluted steel deck roof assembly may be used. The roof assembly shall be constructed of the materials and in the manner described in the individual P900 Series Roof-Ceiling Design in the UL Fire Resistance Directory. The hourly rating of the roof assembly shall be equal to or greater than the hourly rating of the wall assembly and shall include the following construction features:

A. **Steel Roof Deck** — Max 3 in. (76 mm) deep galv steel fluted roof deck.

B. **Roof Insulation** — Min 2-1/4 in. (57 mm) thick poured insulating concrete, as measured from the top plane of the floor units.

C. **Roof Covering\*** — Hot-mopped or cold-application materials compatible with insulating concrete.

2. **Wall Assembly** — The 1, 2, 3 or 4 hr fire rated gypsum board/steel stud wall assembly shall be constructed of the materials and in the manner described in the individual U400 or V400 Series Wall and Partition Design in the UL Fire Resistance Directory and shall include the following construction features:

A. **Steel Floor and Ceiling Runners** — Floor and ceiling runners of wall assembly shall consist of galv steel channels sized to accommodate steel studs (Item 2B). When U-shaped deflection channel (Item 3A) is used, ceiling runner installed within the deflection channel with 1 in. (25 mm) gap maintained between the top of ceiling runner and top of deflection plate. When deflection channel is not used, ceiling runner installed perpendicular to direction of fluted steel deck and secured to valleys with steel masonry anchors or by welds spaced max 24 in. (610 mm) OC.

A1. **Light Gauge Framing\* — Slotted Ceiling Runner** — As an alternate to the ceiling runner in Item 2A, slotted ceiling runner to consist of galv steel channel with slotted flanges sized to accommodate steel studs (Item 2B). Slotted ceiling runner installed perpendicular to direction of fluted steel deck and secured to valleys with steel masonry anchors spaced max 24 in. (610 mm) OC. When slotted ceiling runner is used, deflection channel (Item 3A) shall not be used.

**BRADY CONSTRUCTION INNOVATIONS INC, DBA SLIPTRACK SYSTEMS** — SLP-TRK

**CALIFORNIA EXPANDED METAL PRODUCTS CO** — CST

**CLARKDIETRICH BUILDING SYSTEMS** — Type SLT, SLT-H

**MARINO/WARE, DIV OF WARE INDUSTRIES INC** — Type SLT

**METAL-LITE INC** — The System

**RAM SALES L L C** — RAM Slotted Track

**SCAFCO STEEL STUD MANUFACTURING CO**

**TELLING INDUSTRIES L L C** — True-Action Deflection Track

**A2. Light Gauge Framing\* — Vertical Deflection Ceiling Runner** — As an alternate to the ceiling runner in Items 2A, 2A1 or 2A2, vertical deflection ceiling runner to consist of galv steel channel with slotted vertical deflection clips mechanically fastened within runner. Slotted clips, provided with step bushings, for permanent fastening of steel studs. Vertical deflection ceiling runner installed perpendicular to direction of fluted steel deck and secured to valleys with steel masonry anchors spaced max 24 in. (610 mm) OC. When vertical deflection ceiling runner is used, deflection channel (Item 3A) shall not be used.

**THE STEEL NETWORK INC** — VertiTrack VTD362, VTD400, VTD600 and VTD800

**A3. Light Gauge Framing\*- Notched Ceiling Runner** — As an alternate to the ceiling runners in Items 2A through 2A3, notched ceiling runners to consist of C-shaped galv steel channel with notched return flanges sized to accommodate steel studs (Item 2B). Notched ceiling runner installed perpendicular to direction of fluted steel deck and secured to valleys with steel masonry anchors spaced max 24 in. (610 mm) OC. When notched ceiling runner is used, deflection channel (Item 3A) shall not be used.

**OLMAR SUPPLY INC** — Type SCR

**B. Studs** — Steel studs to be min 3-5/8 in. (92 mm) wide. Studs cut 1/2 to 3/4 in. (13 to 19 mm) less in length than assembly height. Studs attached to ceiling runner with sheet metal screws a min of 1/2 in. (13 mm) below bottom of deflection channel, when deflection channel is used. When deflection channel is not used, studs shall not be secured to ceiling runner. When slotted ceiling runner (Item 2A1) is used steel studs secured to slotted ceiling runner with No. 8 by 1/2 in. (13 mm) long wafer head steel screws at midheight of slot on each side of wall. When vertical deflection ceiling runner (Item 2A3) is used, steel studs secured to slotted vertical deflection clips, through bushings, with steel screws at midheight of each slot. Stud spacing not to exceed 24 in. (610 mm) OC.

**C. Gypsum Board\*** — Gypsum board sheets installed to a min total thickness of 5/8, 1-1/4, 1-7/8 or 2-1/2 in. (16, 32, 48 or 64 mm) on each side of wall for 1, 2, 3, and 4 hr rated assemblies, respectively. Wall to be constructed as specified in the individual Wall and Partition Design in the UL Fire Resistance Directory, except that a nom 3/4 in. (19 mm) gap shall be maintained between the top of the gypsum board and the lower surface of the floor. The screws attaching the gypsum board to studs at the top of the wall shall be located 1 in. (25 mm) below the bottom of the deflection channel, when deflection channel is used. When deflection channel is not used, the screws attaching the gypsum board to studs at the top of the wall shall be located 1 in. (25 mm) below the bottom of the ceiling runner.

**The hourly fire rating of the joint system is dependent on the hourly fire rating of the wall.**

**3. Joint System — Max separation between bottom of floor and top of wall is 3/4 in. (19 mm). The joint system is designed to accommodate a max 33 percent compression or extension from its installed width.** The joint system consists of a deflection channel, forming material and a fill material, as follows:

**A. Deflection Channel** — A nom 3-5/8 in. (92 mm) wide by min 2 in. (51 mm) deep min 24 ga steel U-shaped channel. Deflection channel installed perpendicular to direction of fluted steel deck and secured to valleys with steel masonry anchors or by welds spaced max 24 in. (610 mm) OC. The ceiling runner (Item 2A) is installed within the deflection

channel to maintain a 1 in. (25 mm) gap between the top of the ceiling runner and the top of the deflection channel. The ceiling runner is not fastened to the deflection channel.

**B. Forming Material\*** — Min 4-7/8 in. (124 mm) thickness of min 4 pcf (64 kg/m<sup>3</sup>) density mineral wool batt insulation for 1 and 2 hr rated assemblies, min 7-3/8 in. (187 mm) and min 8-5/8 in. (219 mm) thickness of min 4 pcf (64 kg/m<sup>3</sup>) density mineral wool batt insulation for 3 and 4 hr rated assemblies, respectively, cut to the shape of the fluted deck, approximately 25 percent larger than the area of the flutes and compressed into flutes of the steel floor units between the top of the deflection channel and the steel deck, flush with both sides of wall. Additional pieces of min 5/8 in. (16 mm) thickness of min 4 pcf (64 kg/m<sup>3</sup>) mineral wool batt insulation for 1 and 2 hr rated assemblies, min 1-7/8 in. (48 mm) and min 2-1/2 in. (64 mm) thickness of min 4 pcf (64 kg/m<sup>3</sup>) density mineral wool batt insulation for 3 and 4 hr rated assemblies, respectively, cut into strips and compressed approximately 25 percent to fill the max 3/4 in. (19 mm) gap between the top of the gypsum board and bottom of the steel floor units, flush with both sides of wall.

**INDUSTRIAL INSULATION GROUP L L C** — MinWool-1200 Safing

**ROCK WOOL MANUFACTURING CO** — Delta Safing Board

**THERMAFIBER INC** — Type SAF

**C. Fill, Void or Cavity Material\*** — Min 1/16 in. (1.6 mm) dry thickness (min 1/8 in. or 3.2 mm wet thickness) of fill material sprayed or brushed on each side of the wall in the flutes of the steel floor units and between the top of the gypsum board and the bottom of the steel floor units to completely cover mineral wool and overlap a min of 1 in. (25 mm) onto gypsum board and steel deck on both sides of wall.

**PASSIVE FIRE PROTECTION PARTNERS** — 3500SI, 5100 SP

**\* Indicates such products shall bear the UL or cUL Certification Mark for jurisdictions employing the UL or cUL Certification (such as Canada), respectively.**

Last Updated on 2019-12-26

---

The appearance of a company's name or product in this database does not in itself assure that products so identified have been manufactured under UL's Follow-Up Service. Only those products bearing the UL Mark should be considered to be Certified and covered under UL's Follow-Up Service. Always look for the Mark on the product.

UL permits the reproduction of the material contained in the Online Certification Directory subject to the following conditions: 1. The Guide Information, Assemblies, Constructions, Designs, Systems, and/or Certifications (files) must be presented in their entirety and in a non-misleading manner, without any manipulation of the data (or drawings). 2. The statement "Reprinted from the Online Certifications Directory with permission from UL" must appear adjacent to the extracted material. In addition, the reprinted material must include a copyright notice in the following format: "© 2020 UL LLC"