



XHBN.HW-D-0054 - Joint Systems

Design/System/Construction/Assembly Usage Disclaimer

- Authorities Having Jurisdiction should be consulted in all cases as to the particular requirements covering the installation and use of UL Certified products, equipment, system, devices, and materials.
- Authorities Having Jurisdiction should be consulted before construction.
- Fire resistance assemblies and products are developed by the design submitter and have been investigated by UL for compliance with applicable requirements. The published information cannot always address every construction nuance encountered in the field.
- When field issues arise, it is recommended the first contact for assistance be the technical service staff provided by the product manufacturer noted for the design. Users of fire resistance assemblies are advised to consult the general Guide Information for each product category and each group of assemblies. The Guide Information includes specifics concerning alternate materials and alternate methods of construction.
- Only products which bear UL's Mark are considered Certified.

XHBN - Joint Systems XHBN7 - Joint Systems Certified for Canada

See General Information for Joint Systems

See General Information for Joint Systems Certified for Canada

System No. HW-D-0054

September 26, 2019

ANSI/UL2079	CAN/ULC S115
Assembly Ratings - 1, 2, 3 and 4 Hr (See Item 2)	F Ratings - 1, 2, 3, and 4 Hr (See Item 2)
Nominal Joint Widths - 1-1/2 and 2-1/2 In. (See Item 3)	FT Ratings - 1, 2, 3, and 4 Hr (See Item 2)
Class II Movement Capabilities - 40 or 50% Compression or Extension (See Item 3)	FH Ratings - 1, 2, 3, and 4 Hr (See Item 2)
L Rating At Ambient - Less Than 1 CFM/Lin Ft	FTH Ratings - 1, 2, 3, and 4 Hr (See Item 2)
L Rating At 400 F - Less Than 1 CFM/Lin Ft	Nominal Joint Widths - 1-1/2 and 2-1/2 In. (See Item 3)
	Class II Movement Capabilities - 40 or 50% Compression or Extension (See Item 3)
	L Rating At Ambient - Less Than 1 CFM/Lin Ft
	L Rating At 400 F - Less Than 1 CFM/Lin Ft

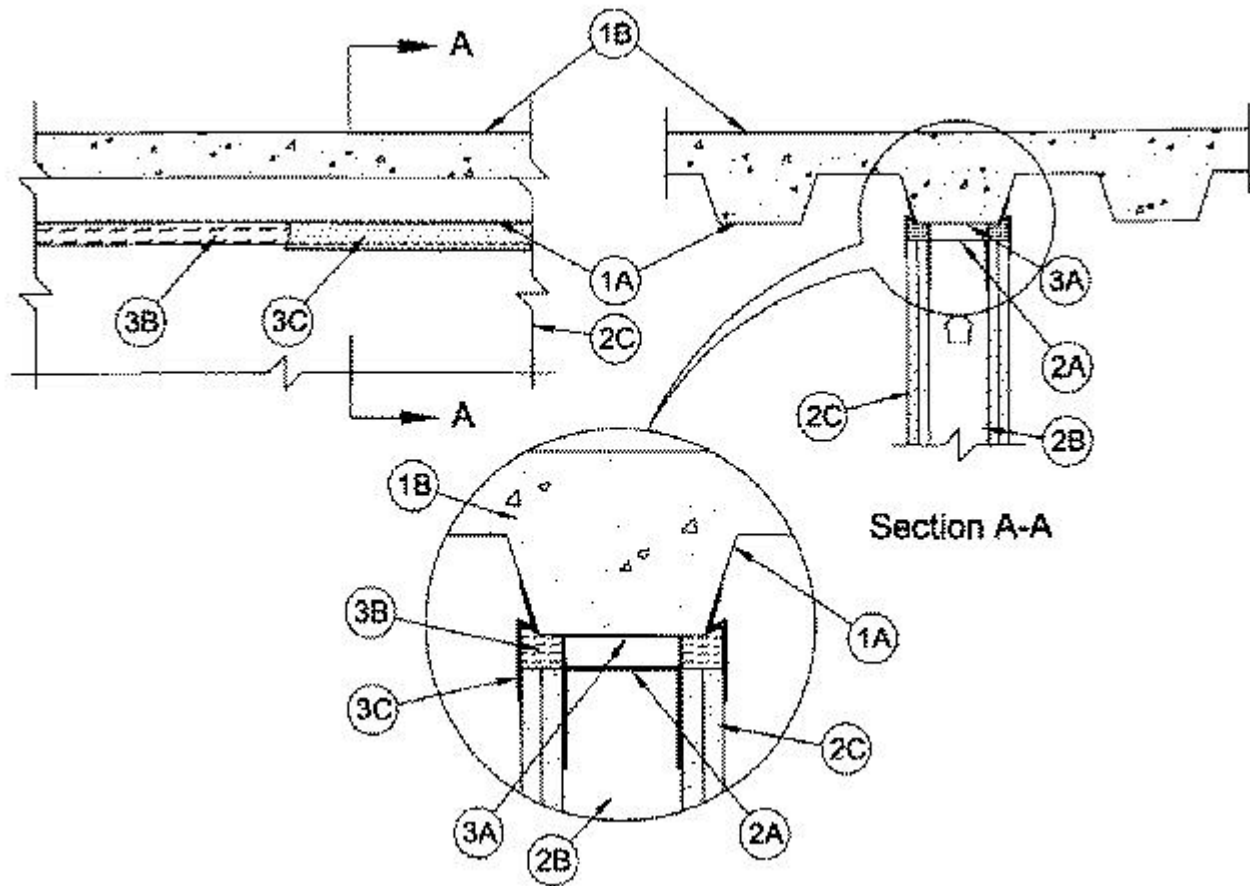

1. Floor Assembly — The fire-rated fluted steel deck/concrete floor assembly shall be constructed of the materials and in the manner described in the individual Floor-Ceiling Design in the UL Fire Resistance Directory and shall include the following construction features:

A. **Steel Floor and Form Units*** — Max 3 in. (76 mm) deep galv steel fluted floor units having a min valley width of 4-3/4 in. (121 mm).

B. **Concrete** — Min 2-1/2 in. (64 mm) thick reinforced concrete, as measured from the top plane of the floor units.

1A. Roof Assembly — (Not Shown) — As an alternate to the floor assembly (Item 1), a fire rated fluted steel deck roof assembly may be used. The roof assembly shall be constructed of the materials and in the manner described in the individual P900 Series Roof-Ceiling Design in the UL Fire Resistance Directory. The hourly fire rating of the roof assembly shall be equal to or greater than the hourly fire rating of the wall assembly. The roof assembly shall include the following construction features:

A. **Steel Roof Deck** — Max 3 in. (76 mm) deep galv steel fluted roof deck having a min valley width of 4-3/4 in.

B. **Roof Insulation** — Min 2-1/4 in. (57 mm) thick poured insulating concrete, as measured from the top plane of the steel roof deck.

C. **Roof Covering*** — Hot mopped or cold-application materials compatible with insulating concrete.

2. Wall Assembly — The 1, 2, 3 or 4 hr fire-rated gypsum board/stud wall assembly shall be constructed of the materials and in the manner described in the individual U400, V400 or W400 Series Wall and Partition Design in the UL Fire Resistance Directory and shall include the following construction features:

A. **Steel Floor and Ceiling Runners** — Floor and ceiling runners of wall assembly shall consist of galv steel channels sized to accommodate steel studs. Ceiling runner to be provided with min 1-1/4 in. (32 mm) to max 3 in. (76 mm) flanges. When deflection channel (Item 3A) is used, flange height of ceiling runner is to be equal to or greater than flange height of deflection channel and the ceiling runner is to nest within the deflection channel with a 3/4 to 1 in. (19 to 25 mm) gap maintained between the top of the ceiling runner and the top of the deflection channel. When

deflection channel is not used, ceiling runner installed parallel to direction of fluted steel deck, centered beneath valley, and secured with steel masonry anchors or welds spaced max 24 in. (610 mm) OC.

A1. Light Gauge Framing* — Slotted Ceiling Runner — As an alternate to the ceiling runner in Items 2A and 2A1, slotted ceiling runner consisting of galv steel channel with slotted flanges sized to accommodate steel studs (Item 2B). Slotted ceiling runner installed parallel with direction of fluted steel deck, centered beneath valley, and secured with steel masonry anchors or welds spaced max 24 in. (610 mm) OC. When slotted ceiling runner is used, deflection channel (Item 3A) shall not be used.

BRADY CONSTRUCTION INNOVATIONS INC, DBA SLIPTRACK SYSTEMS — SLP-TRK

CALIFORNIA EXPANDED METAL PRODUCTS CO — CST

CLARKDIETRICH BUILDING SYSTEMS — Type SLT, SLT-H

MARINO/WARE, DIV OF WARE INDUSTRIES INC — Type SLT

QUAIL RUN BUILDING MATERIALS INC — Slotted Deflection Track

RAM SALES L L C — RAM Slotted Track

SCAFCO STEEL STUD MANUFACTURING CO

STEELER INC — Steeler Slotted Ceiling Runner

TELLING INDUSTRIES L L C — True-Action Deflection Track

A2. Light Gauge Framing* - Vertical Deflection Ceiling Runner — As an alternate to the ceiling runner in Items 2A, 2A1 and 2A2, vertical deflection ceiling runner consisting of galv steel channel with slotted vertical deflection clips mechanically fastened within runner. Slotted clips, provided with step bushings, for permanent fastening of steel studs. Vertical deflection ceiling runner installed parallel with direction of fluted steel deck, centered beneath valley, and secured with steel masonry anchors or welds spaced max 24 in. (610 mm) OC. When vertical deflection ceiling runner is used, deflection channel (Item 3A) shall not be used.

A3. Light Gauge Framing*- Notched Ceiling Runner — As an alternate to the ceiling runners in Items 2A through 2A3, notched ceiling runners to consist of C-shaped galv steel channel with notched return flanges sized to accommodate steel studs (Item 2B). Notched ceiling runner installed parallel to direction of fluted steel deck, centered beneath valley, and secured with steel masonry anchors spaced max 24 in. (610 mm) OC. When notched ceiling runner is used, deflection channel (Item 3A) shall not be used.

OLMAR SUPPLY INC — Type SCR

B. Studs — Steel studs to be min 3-5/8 in. (92 mm) wide. Studs cut 1/2 to 3/4 in. (13 to 19 mm) less in length than assembly height with bottom nesting in and secured to floor runner. When deflection channel (Item 3A) is used, steel studs attached to ceiling runner (Item 2A) with sheet metal screws located 3/4 in. (19 mm) below the bottom to the deflection channel. When deflection channel is not used, studs to nest in ceiling runner without attachment. When slotted ceiling runner (Item 2A2) is used, steel studs secured to slotted ceiling runner with No. 8 by 1/2 in. (13 mm) long wafer head steel screws at midheight of slot on each side of wall. When vertical deflection ceiling runner (Item 2A3) is used, steel studs secured to slotted vertical deflection clips, through bushings, with steel screws at midheight of each slot. Stud spacing not to exceed 24 in. (610 mm) OC.

B1. Light Gauge Framing* —Slotted Studs — Slotted steel stud to be used in conjunction with **Light Gauge Framing* —Floor and Ceiling Runners** (Item 2A2). Slotted steel studs to be min 3-5/8 in. (92 mm) wide. Slotted steel

studs cut 1/2 in. to 3/4 in. (13 to 19 mm) less in length than assembly height with bottom nesting in and secured to both ceiling and floor runners. Ceiling runner secured to preformed slot within steel stud by means of No. 10 by 3/4 in. (19 mm) long low profile head steel screw. Floor runner attached to bottom of steel stud by means of No. 8 by 1/2 in. (13 mm) long pan head steel screw. Slotted steel stud spacing not to exceed 24 in. (610 mm) OC.

STEELER INC — Steeler Slotted Stud

C. **Gypsum Board*** — Gypsum board sheets installed to a min total 5/8 in., 1-1/4 in., 1-1/2 in. or 2 in. (16, 32, 38 or 51 mm) thickness on each side of wall for 1, 2, 3 and 4 hr rated assemblies, respectively. Wall to be constructed as specified in the individual U400 or V400, U400 or W400 Series Design in the UL Fire Resistance Directory, except that a max 2 in. (51 mm) gap shall be maintained between the top of the gypsum board and the lower surface of the steel floor or roof deck. The screws attaching the gypsum board to the studs along the top of the wall shall be located 1 in. (25 mm) below the bottom of the ceiling runner. No gypsum board attachment screws shall be driven into the ceiling runner or into the optional deflection channel.

The hourly fire rating of the joint system is equal to the hourly fire rating of the wall.

3. Joint System — Max separation between bottom of floor or roof deck and top of gypsum board (at time of installation of joint system) is 2-1/2 in. (64 mm) for 1 and 2 hr Ratings and 1 in. (25 mm) for 3 and 4 hr Ratings. The joint system is designed to accommodate a max 50 percent compression or extension from its installed width for max 1-1/2 in. (38 mm) wide joints and a max 40 percent compression or extension from its installed width for max 2-1/2 in. (64 mm) wide joints. The joint system shall consist of forming and fill materials, with or without a deflection channel (Item 3A), as follows:

A. **Deflection Channel** — Max 3 in. (76 mm) deep min 24 gauge galv steel channel sized to accommodate ceiling runner (Item 2A). Deflection channel installed parallel to direction of fluted steel deck, centered beneath valley, and secured with steel masonry anchors or welds spaced max 24 in. (610 mm) OC. The ceiling runner (Item 2A) is installed within the deflection channel to maintain a 1/2 to 1 in. (13 to 25 mm) gap between the top of the ceiling runner and the top of the deflection channel. The ceiling runner nests inside the deflection channel without attachment.

B. **Forming Material*** — Sections of nom 4 pcf (64 kg/m³) density mineral wool batt insulation to be cut to the width of the gypsum board layers. Strips of mineral wool compressed 50 percent in thickness and installed cut edge first to fill the gap between the top of the gypsum board and the bottom of the steel floor or roof deck. The forming material shall be installed flush with both surfaces of wall.

INDUSTRIAL INSULATION GROUP L L C — MinWool-1200 Safing

ROCK WOOL MANUFACTURING CO — Delta Board

ROCKWOOL MALAYSIA SDN BHD — Safe

ROCKWOOL — Safe

THERMAFIBER INC — Type SAF

C. **Fill, Void or Cavity Material* — Sealant** — Min 1/8 in. (3.2 mm) wet thickness (min 1/16 in. or 1.6 mm dry thickness) of fill material spray applied on each side of the wall between the top of the wall and the bottom of the steel floor or roof deck, overlapping min 1/2 in. (13 mm) on both the gypsum board and the steel floor or roof deck on both sides of wall.

SPECIFIED TECHNOLOGIES INC — SpecSeal AS 200 Elastomeric Spray

*** Indicates such products shall bear the UL or cUL Certification Mark for jurisdictions employing the UL or cUL Certification (such as Canada), respectively.**

The appearance of a company's name or product in this database does not in itself assure that products so identified have been manufactured under UL's Follow-Up Service. Only those products bearing the UL Mark should be considered to be Certified and covered under UL's Follow-Up Service. Always look for the Mark on the product.

UL permits the reproduction of the material contained in the Online Certification Directory subject to the following conditions: 1. The Guide Information, Assemblies, Constructions, Designs, Systems, and/or Certifications (files) must be presented in their entirety and in a non-misleading manner, without any manipulation of the data (or drawings). 2. The statement "Reprinted from the Online Certifications Directory with permission from UL" must appear adjacent to the extracted material. In addition, the reprinted material must include a copyright notice in the following format: "© 2020 UL LLC"