



XHBN.HW-D-0045 - Joint Systems

Design/System/Construction/Assembly Usage Disclaimer

- Authorities Having Jurisdiction should be consulted in all cases as to the particular requirements covering the installation and use of UL Certified products, equipment, system, devices, and materials.
- Authorities Having Jurisdiction should be consulted before construction.
- Fire resistance assemblies and products are developed by the design submitter and have been investigated by UL for compliance with applicable requirements. The published information cannot always address every construction nuance encountered in the field.
- When field issues arise, it is recommended the first contact for assistance be the technical service staff provided by the product manufacturer noted for the design. Users of fire resistance assemblies are advised to consult the general Guide Information for each product category and each group of assemblies. The Guide Information includes specifics concerning alternate materials and alternate methods of construction.
- Only products which bear UL's Mark are considered Certified.

XHBN - Joint Systems

See General Information for Joint Systems

System No. HW-D-0045

February 07, 2019

Assembly Rating — 1 and 2 Hr (See Item 2)

Nominal Joint Width — 3/4 In.

Class II Movement Capabilities — 33% Compression or Extension

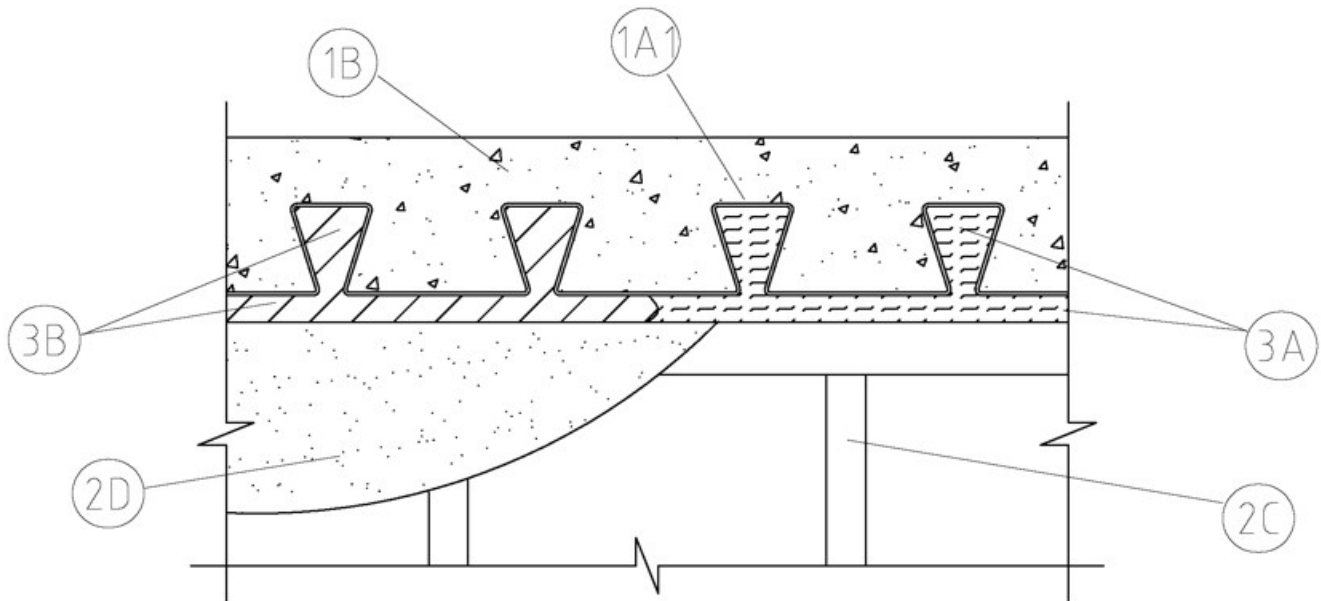
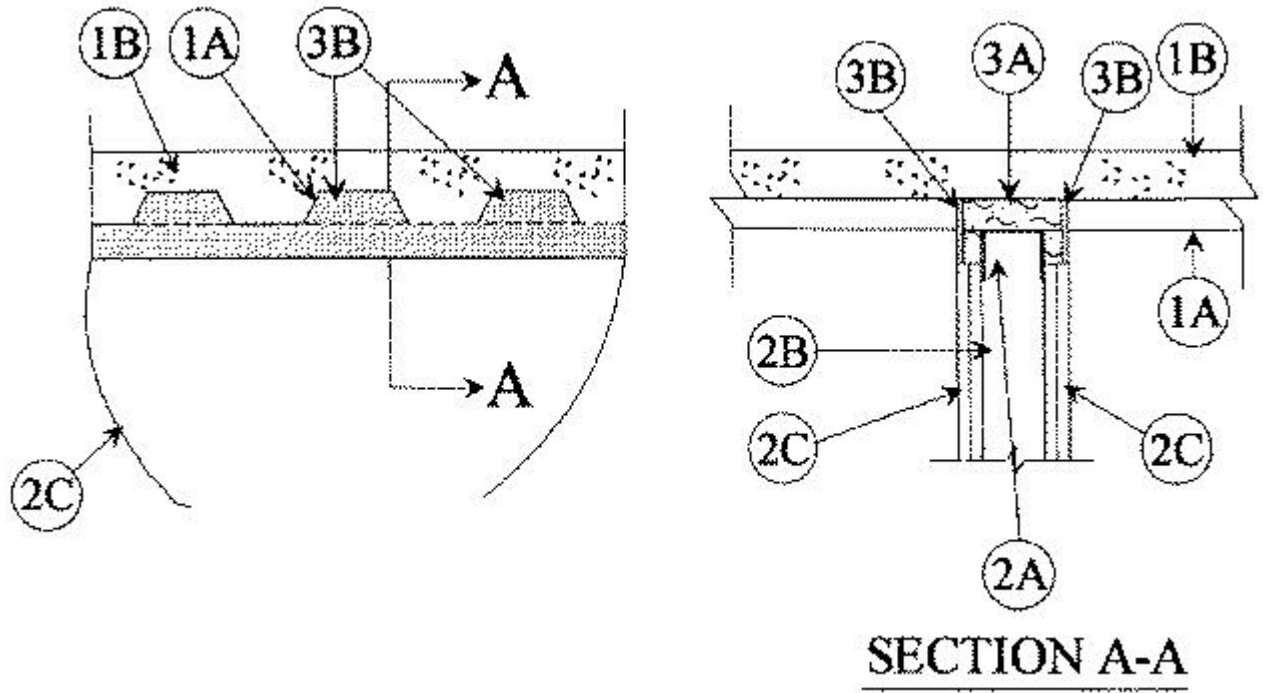

CONFIGURATION B

1. **Floor Assembly** — The fire-rated fluted steel floor unit/concrete floor assembly shall be constructed of the materials and in the manner described in the individual Floor-Ceiling Design in the Fire Resistance Directory and shall include the following construction features:

A. **Steel Floor and Form Units*** — Max 3 in. (76 mm) deep galv steel fluted floor units.

A1. **Steel Floor And Form Units* (Configuration B)** — Composite max 2.5 in. (64 mm) deep galv steel fluted units.
EPIC METALS CORP — Types "EC" or "Toris C"

B. **Concrete** — Min 2-1/2 in. (64 mm) thick reinforced concrete, as measured from the top plane of the floor units.

1A. **Roof Assembly** — (Not Shown) — As an alternate to the floor assembly, a fire rated fluted steel deck roof assembly may be used. The roof assembly shall be constructed of the materials and in the manner described in the individual P900 Series Roof-Ceiling Design in the UL Fire Resistance Directory. The hourly rating of the roof assembly shall be equal to or greater than the hourly rating of the wall assembly. The roof assembly shall include the following construction features:

A. **Steel Roof Deck** — Max 3 in. (76 mm) deep galv steel fluted roof deck.

A1. **Steel Floor And Form Units* (Configuration B)** — Composite max 2.5 in. (64 mm) deep galv steel fluted units.
EPIC METALS CORP — Types "Toris C" or "ER2R"

B. **Roof Insulation** — Min 2-1/4 in. (57 mm) thick poured insulating concrete, as measured from the top plane of the floor units.

2. **Wall Assembly** — The 1 or 2 hr fire-rated gypsum board /stud wall assembly shall be constructed of the materials and in the manner specified in the individual U400 or V400 Series Wall and Partition Design in the UL Fire Resistance Directory and shall include the following construction features:

A. **Steel Floor and Ceiling Runners** — Floor and ceiling runners of wall assembly shall consist of galv steel channels sized to accommodate steel studs (Item 2B). Flange height of ceiling runner shall be min 1/4 in. (6 mm) greater than max extended joint width. . Ceiling runner installed perpendicular to direction of fluted steel deck and secured to valleys with steel fasteners or by welds spaced max 24 in. (610 mm) OC.

A1. **Light Gauge Framing* — Slotted Ceiling Runner** — As an alternate to the ceiling runner in Item 2A, slotted ceiling runner to consist of galv steel channel with slotted flanges sized to accommodate steel studs (Item 2B). Slotted ceiling runner installed perpendicular to direction of fluted steel deck and secured to valleys with steel fasteners or welds spaced max 24 in. (610 mm) OC.

BRADY CONSTRUCTION INNOVATIONS INC, DBA SLIPTRACK SYSTEMS — SLP-TRK

CALIFORNIA EXPANDED METAL PRODUCTS CO — CST

CLARKDIETRICH BUILDING SYSTEMS — Type SLT, SLT-H

MARINO/WARE, DIV OF WARE INDUSTRIES INC — Type SLT

METAL-LITE INC — The System

RAM SALES L L C — RAM Slotted Track

SCAFCO STEEL STUD MANUFACTURING CO

TELLING INDUSTRIES L L C — True-Action Deflection Track

A2. **Light Gauge Framing* — Vertical Deflection Ceiling Runner** — As an alternate to the ceiling runners in Item 2A and 2A1, vertical deflection ceiling runner to consist of galv steel channel with slotted vertical deflection clips

mechanically fastened within runner. Slotted clips provided with step bushings for permanent fastening of steel studs. Flanges sized to accommodate steel studs (Item 2B). Vertical deflection ceiling runner installed perpendicular to direction of fluted steel deck and secured to valleys with steel fasteners or welds spaced max 24 in. (610 mm) OC.

THE STEEL NETWORK INC — VertiTrack VTD250, VTD362, VTD400, VTD600 and VTD800

A3. Light Gauge Framing* — Notched Ceiling Runner — As an alternate to the ceiling runners in Items 2A through 2A3, notched ceiling runners to consist of C-shaped galv steel channel with notched return flanges sized to accommodate steel studs (Item 2B). Notched ceiling runner installed perpendicular to direction of fluted steel deck and secured to valleys with steel fasteners or welds spaced max 24 in. (610 mm) OC.

OLMAR SUPPLY INC — Type SCR

B. Studs — Steel studs to be min 2-1/2 in. (64 mm) wide. Studs cut 1/2 to 3/4 in. (13 to 19 mm) less in length than assembly height with bottom nesting in and resting on floor runner and with top nesting in ceiling runner without attachment. When Epic Metals composite floor or roof deck (Item 1A1) is used, steel studs to be min 3-5/8 in. (92 mm) wide. When slotted ceiling runner (Item 2A1) is used, steel studs secured to slotted ceiling runner with No. 8 by 1/2 in. (13 mm) long wafer head steel screws at midheight of slot on each side of wall. When vertical deflection ceiling runner (Item 2A2) is used, steel studs secured to slotted vertical deflection clips, through the bushings, with steel screws at midheight of each slot. Stud spacing not to exceed 24 in. (610 mm) OC.

C. Gypsum Board* — For 1 hr assembly, one layer of 5/8 in. (16 mm) thick gypsum board is required in the individual Wall and Partition Design. For 2 hr assembly, two layers of 5/8 in. (16 mm) thick gypsum board is required in the individual Wall and Partition Design. For both hourly ratings, a nominal 3/4 in. (19 mm) gap shall be maintained between the top of the gypsum board and the bottom surface of the steel floor units and the top row of screws shall be installed into the studs 3 in. (76 mm) below the valleys of the steel floor units.

The hourly rating of the joint system is dependent on the hourly fire rating of the wall.

3. Joint System — Max separation between bottom of floor or roof and top of wall is 3/4 in. (19 mm). The joint system is designed to accommodate a max 33 percent compression or extension from its installed width. The joint system consists of a packing material and a fill material between the top of the gypsum board and the bottom of the floor or roof, as follows:

A. Forming Material* — Nom 4 pcf (64 kg/m³) mineral wool batt insulation, cut to the shape of the trapezoidal fluted deck, approx 20 percent larger than the area of the flutes and compressed into the flutes of the steel deck flutes above the ceiling runner. The mineral wool insulation is to project beyond each side of the ceiling runner, recessed 1/2 in. (13 mm) from both wall surfaces. When Epic Metals Type "EC", Type "ER2R" or Type "Toris C" decks (Item 1A1) are used, the mineral wool is to be tightly packed into the inverted flutes and recessed 1/2 in. (13 mm) from both wall surfaces to accommodate Item 3B. In addition, for the Epic Metals "Toris C" deck, the mineral wool is to be packed to min 25% compression within the recessed indentations immediately above the ceiling runners. For 2 hr assembly, an additional 1-1/2 in. (38 mm) thick by 3/4 in. (19 mm) wide sections of mineral wool batt insulation compressed 50 percent and installed cut edge first to fill the 3/4 in. (19 mm) gap between the top of gypsum board and bottom of the steel deck. The forming material shall be recessed 1/2 in. (13 mm) from each side of the wall.

ROCK WOOL MANUFACTURING CO — Delta Board

ROCKWOOL — SAFE

THERMAFIBER INC — Type SAF

A1. Forming Material* — Plugs — (Optional, Not Shown) — Preformed mineral wool plugs, formed to the shape of the fluted floor units, friction fit to completely fill the flutes above the ceiling channel. The plugs shall project beyond each side of the ceiling runner and shall be recessed 1/2 in. (13 mm) from both wall surfaces. Additional forming

material, described in Item 3A, to be used in conjunction with the plugs to fill the gap between the top of gypsum board and bottom of steel deck.

HILTI CONSTRUCTION CHEMICALS, DIV OF HILTI INC — CP777 Speed Plugs

B. Fill, Void or Cavity Material* — Sealant — Min 1/2 in. (13 mm) thickness of fill material installed on each side of the wall in the flutes of the steel deck and between the top of the gypsum board and the bottom of the steel deck, flush with each surface of the wall.

HILTI CONSTRUCTION CHEMICALS, DIV OF HILTI INC — CP606 Flexible Firestop Sealant

*** Indicates such products shall bear the UL or cUL Certification Mark for jurisdictions employing the UL or cUL Certification (such as Canada), respectively.**

Last Updated on 2019-02-07

The appearance of a company's name or product in this database does not in itself assure that products so identified have been manufactured under UL's Follow-Up Service. Only those products bearing the UL Mark should be considered to be Certified and covered under UL's Follow-Up Service. Always look for the Mark on the product.

UL permits the reproduction of the material contained in the Online Certification Directory subject to the following conditions: 1. The Guide Information, Assemblies, Constructions, Designs, Systems, and/or Certifications (files) must be presented in their entirety and in a non-misleading manner, without any manipulation of the data (or drawings). 2. The statement "Reprinted from the Online Certifications Directory with permission from UL" must appear adjacent to the extracted material. In addition, the reprinted material must include a copyright notice in the following format: "© 2020 UL LLC"