



BXUV.H508 -

Design/System/Construction/Assembly Usage Disclaimer

- Authorities Having Jurisdiction should be consulted in all cases as to the particular requirements covering the installation and use of UL Certified products, equipment, system, devices, and materials.
- Authorities Having Jurisdiction should be consulted before construction.
- Fire resistance assemblies and products are developed by the design submitter and have been investigated by UL for compliance with applicable requirements. The published information cannot always address every construction nuance encountered in the field.
- When field issues arise, it is recommended the first contact for assistance be the technical service staff provided by the product manufacturer noted for the design. Users of fire resistance assemblies are advised to consult the general Guide Information for each product category and each group of assemblies. The Guide Information includes specifics concerning alternate materials and alternate methods of construction.
- Only products which bear UL's Mark are considered Certified.

BXUV - Fire Resistance Ratings - ANSI/UL 263 Certified for United States

BXUV7 - Fire Resistance Ratings - CAN/ULC-S101 Certified for Canada

See General Information for Fire-resistance Ratings - ANSI/UL 263 Certified for United States
Design Criteria and Allowable Variances

See General Information for Fire Resistance Ratings - CAN/ULC-S101 Certified for Canada
Design Criteria and Allowable Variances

Design No. H508

October 23, 2018

Unrestrained Assembly Rating — 1 Hr.

This design was evaluated using a load design method other than the Limit States Design Method (e.g., Working Stress Design Method). For jurisdictions employing the Limit States Design Method, such as Canada, a load restriction factor shall be used — See Guide BXUV or BXUV7

*** Indicates such products shall bear the UL or cUL Certification Mark for jurisdictions employing the UL or cUL Certification (such as Canada), respectively.**

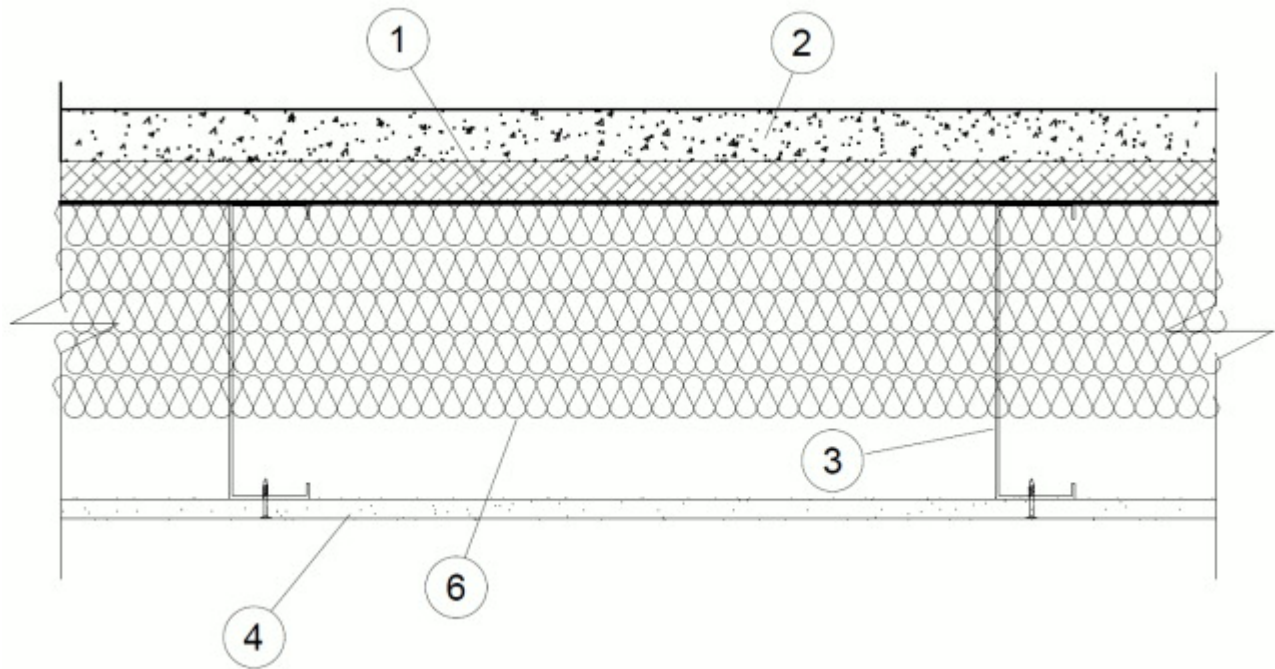

1. Units, Partition Panel* — Steel faced panels. Minimum 11/16 in. thick panels secured to top chord of steel joists with #8, 1-5/8 in. cement board Grabber screws spaced 6 in. OC.

CALIFORNIA EXPANDED METAL PRODUCTS CO — Sure-Board® Series 200S

MARINO/WARE, DIV OF WARE INDUSTRIES INC — Sure-Board® Series 200S

2. Floor Topping Mixture* — Compressive strength to be 2500 psi min. Minimum thickness to be 1 in. as measured from the top plane of the **Floor Mat Material***. Refer to manufacturer's instructions accompanying the material for specific mix design.

UNITED STATES GYPSUM CO — LRK

Floor Mat Materials* — (Not shown) — Floor mat material loose laid over the partition panels (Item 1).

UNITED STATES GYPSUM CO — Types LEVELROCK® Brand Sound Reduction Board

3. Steel Joists — C-shaped, galvanized steel sections, 12 in. min depth with 2 in. min. flanges and 5/8 in. min. stiffening flanges. The web of each joist may be provided with maximum 1-1/2 in. high by 3-1/2 in. long rectangular or oval shaped knockouts at the joist mid-depth. Knockouts spaced 24 in. OC minimum. The minimum coated steel thickness shall be 0.070 in. Joists spaced max 24 in. OC. At joist rim splices bearing on supports, joists rims are connected using an overlapping section of a 20 in. long splice plate (a joist piece), with four 3/4 in. long self-drilling #10-16 TEK screws to each rim piece. Joists secured to joist rims with three 3/4 in. TEK screws secured through both legs of minimum 3 in. by 3 in. by 9 in. long .070 in. thick steel angles.

3A. Bridging — (Not Shown) — For use with Item 3 — Location of lateral bracing to be specified on joist engineering. 10 in. deep sections with 1-1/4 in. min flanges. Minimum coated steel thickness shall be .055 in. Bridging secured with three 3/4 in. TEK screws secured through both legs of minimum 3 in. by 3 in. by 9 in. long steel angles.

3B. Structural Steel Members* — As an alternate to Item 3. The proprietary Sure-Span joists are channel-shaped, 12 in. min depth. Joists are fabricated from min coated 0.070 in. steel thickness. Joists spaced max 24 in. OC. Joists attached to rim joist with a minimum of three #10 3/4 in. long self-drilling screws at the rim track clip to the outside of the web joist, and a #10 1/2 in. long screw through the top and bottom flange of the joists to the top and bottom flange of the rim track. At rim joist splices bearing on supports, rim joists are connected using an overlapping section of a 12 in. long splice plate (a joist piece), with a minimum of six 3/4 in. long self-drilling #10 screws to each rim piece.

CALIFORNIA EXPANDED METAL PRODUCTS CO — Type SSCJ floor joists, SSRT rim joists or Type SSTT rim joists. When Type SSTT rim joists are used, secured to preformed clip tabs in accordance with manufacturers installation instructions.

3C. Joist Bridging — Not Shown — For use with Item 3B. - Installed immediately after joists are erected and before construction loads are applied. The structural bridging, Type CEMCO Sure Bridging, consisting of No. 14 MSG galv steel, 2-1/2 in. wide by 25-1/2 in. long with 1-5/16 in. long legs structural bridging staggered between the steel joists and attached to the bottom joist flange with two #10 1/2 in. long self-drilling screws at each end tab of bridging. Solid bridging consisting of cut to length joist sections placed between outer joists and at center joist with 8 ft OC max spacing. Solid bridging is seated in the structural bridging and is screw-attached at joist web using Type CEMCO Sure-Support Clips (1-1/2 in. by 1-1/2 in. by 7 in. long, 14 MSG, min 50 ksi support clip) with three #10 3/4 in. long self-drilling screws per leg on one side and the other side with Type CEMCO Sure-Support Clips (4 in. by 1-1/2 in. by 7 in. long, 14 MSG, min 50 ksi support clip) with three #10 3/4 in. long self-drilling screws per leg.

4. Gypsum Board* — Single layer of nom 5/8 in. thick, 48 in. wide gypsum panels installed with long dimension perpendicular to steel joists. Gypsum panels secured with 1-1/4 in. long Type S bugle-head screws. Screws spaced 1-1/2 from side edges of the board and 6 in. OC in the field. Butt joints of adjacent pieces offset minimum 4 ft.

NATIONAL GYPSUM CO — Type FSW-C

5. Insulation Pins — (not shown) - 9-1/2 in. long, 12 ga steel pins with 2 in. by 2 in. perforated bases. Secured to underside of steel faced panels (Item 1) with one No. 8 by 1/2 in. self-drilling steel screw. Six pins spaced symmetrically in field of 2 ft. by 4 ft. sections of insulation batts (Item 7) so as to be spaced nominally 20 in. apart, offset 4 in. from batt edges. Pins penetrated through insulation batts. Batts secured to pins with 1-1/2 in. by 1-1/2 in. by .016 in. locking washers.

6. Batts and Blankets* — Mineral wool or glass fiber insulation, min 9-1/2 in. thick and 0.4 psf. Insulation fitted in the concealed space, draped over the resilient channels.

7. Joint System — Not Shown — Vinyl, dry or premixed joint compound, applied in two coats to joints and screw heads; paper tape, 2 in. wide, embedded in first layer of compound over all joints.

*** Indicates such products shall bear the UL or cUL Certification Mark for jurisdictions employing the UL or cUL Certification (such as Canada), respectively.**

Last Updated on 2018-10-23

The appearance of a company's name or product in this database does not in itself assure that products so identified have been manufactured under UL's Follow-Up Service. Only those products bearing the UL Mark should be considered to be Certified and covered under UL's Follow-Up Service. Always look for the Mark on the product.

UL permits the reproduction of the material contained in the Online Certification Directory subject to the following conditions: 1. The Guide Information, Assemblies, Constructions, Designs, Systems, and/or Certifications (files) must be presented in their entirety and in a non-misleading manner, without any manipulation of the data (or drawings). 2. The statement "Reprinted from the Online Certifications Directory with permission from UL" must appear adjacent to the extracted material. In addition, the reprinted material must include a copyright notice in the following format: "© 2020 UL LLC"