



## BXUV.G588 -

## Design/System/Construction/Assembly Usage Disclaimer

- Authorities Having Jurisdiction should be consulted in all cases as to the particular requirements covering the installation and use of UL Certified products, equipment, system, devices, and materials.
- Authorities Having Jurisdiction should be consulted before construction.
- Fire resistance assemblies and products are developed by the design submitter and have been investigated by UL for compliance with applicable requirements. The published information cannot always address every construction nuance encountered in the field.
- When field issues arise, it is recommended the first contact for assistance be the technical service staff provided by the product manufacturer noted for the design. Users of fire resistance assemblies are advised to consult the general Guide Information for each product category and each group of assemblies. The Guide Information includes specifics concerning alternate materials and alternate methods of construction.
- Only products which bear UL's Mark are considered Certified.

## BXUV - Fire Resistance Ratings - ANSI/UL 263 Certified for United States

## BXUV7 - Fire Resistance Ratings - CAN/ULC-S101 Certified for Canada

See General Information for Fire-resistance Ratings - ANSI/UL 263 Certified for United States  
Design Criteria and Allowable Variances

See General Information for Fire Resistance Ratings - CAN/ULC-S101 Certified for Canada  
Design Criteria and Allowable Variances

**Design No. G588**

November 12, 2019

**Unrestrained Assembly Rating — 1, 1-1/2 and 2 Hr (See Items 1 and 2)**

**This design was evaluated using a load design method other than the Limit States Design Method (e.g., Working Stress Design Method). For jurisdictions employing the Limit States Design Method, such as Canada, a load restriction factor shall be used — See Guide BXUV or BXUV7**

**\* Indicates such products shall bear the UL or cUL Certification Mark for jurisdictions employing the UL or cUL Certification (such as Canada), respectively.**

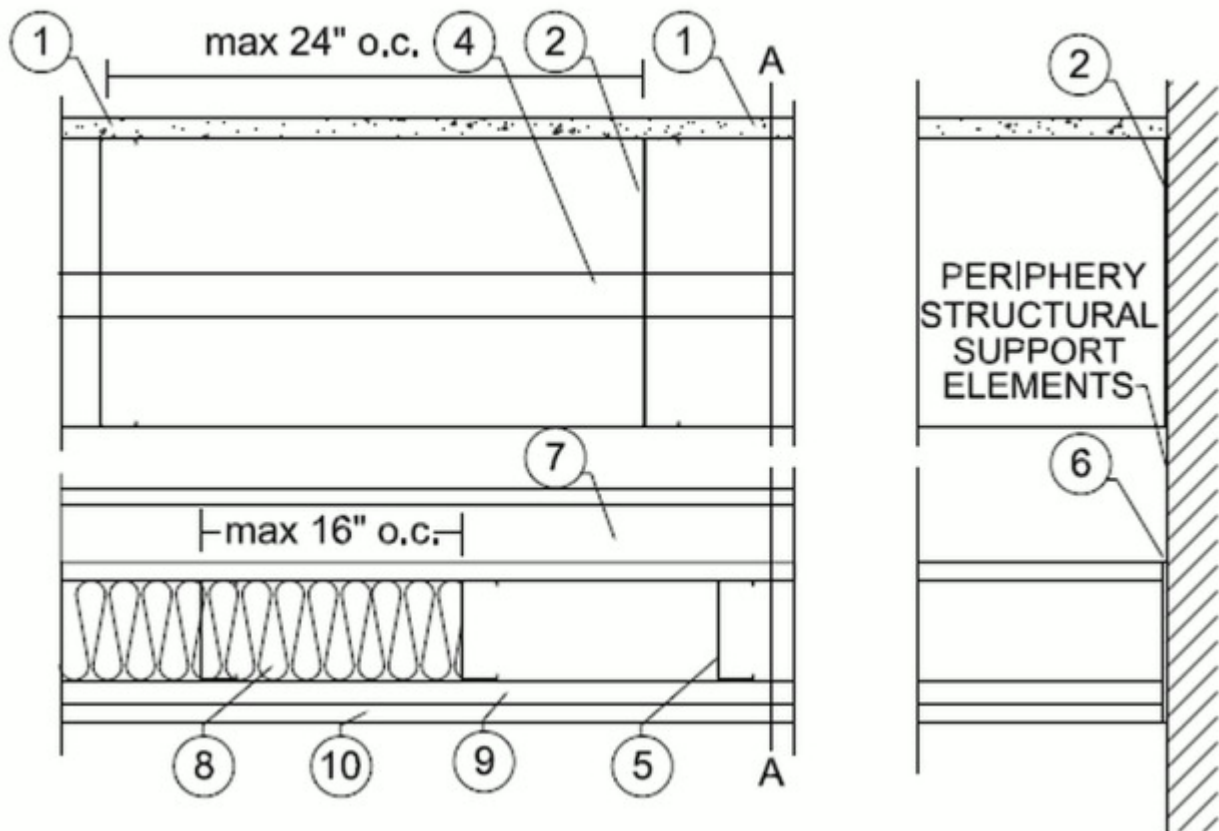

## 1 or 1-1/2 Hr Rating

1A. **Structural Cement-Fiber Units\*** — Nom 3/4 in. thick, with long edges tongue and grooved. Long dimension of panels to be perpendicular to joists with end joints staggered a min of 2 ft and centered over the joists. Panels secured to steel joists with 1-5/8 in. long No. 8 self-drilling, self-countersinking steel screws spaced a max of 12 in. OC in the field with a screw located 1 in. and 2 in. from each edge, and 8 in. OC on the perimeter with a screw located 2 in. from each edge, located 1/2 in. from the side edges of the panel. Unrestrained Assembly Rating is 1 hour when Item 2A or 2B is used. **Unrestrained Assembly Rating is 1-1/2 hour when Item 2 is used.**

**UNITED STATES GYPSUM CO** — Types STRUCTO-CRETE, USGSP

## 2 Hr Rating System A

1A. **Structural Cement-Fiber Units\*** — Nom 3/4 in. thick, with long edges tongue and grooved. Long dimension of panels to be perpendicular to joists with end joints staggered a min of 2 ft and centered over the joists. Panels secured to steel joists with 1-5/8 in. long No. 8 self-drilling, self-countersinking steel screws spaced a max of 12 in. OC in the field with a screw located 1 in. and 2 in. from each edge, and 8 in. OC on the perimeter with a screw located 2 in. from each edge, located 1/2 in. from the side edges of the panel.

**UNITED STATES GYPSUM CO** — Types STRUCTO-CRETE, USGSP

1B. **Gypsum Board\* (Not Shown)** — Min 1/2 in. thick, 4 ft by 4 ft gypsum board underlayment, Classified as to Surface Burning Characteristics. Bonded and attached to Structural Cement Fiber Units (Item 1A) with a mortar applied with a 1/4 in. by 1/4 in. notched trowel, and 1-1/4 in. long coarse thread screws spaced max 8 in. OC. Joints between Structural Cement Fiber Units and of Gypsum Board staggered a min of 6 in.

**UNITED STATES GYPSUM CO** — Type FRX-G

**USG MEXICO S A DE C V** — Types LRK, HSLRK, CSD

## System B

1A. **Structural Cement-Fiber Units\*** — Nom 3/4 in. thick, with long edges tongue and grooved. Long dimension of panels to be perpendicular to joists with end joints staggered a min of 2 ft and centered over the joists. Panels secured to steel joists with 1-5/8 in. long No. 8 self-drilling, self-countersinking steel screws spaced a max of 12 in. OC in the field with a screw located 1 in. and 2 in. from each edge, and 8 in. OC on the perimeter with a screw located 2 in. from each edge, located 1/2 in. from the side edges of the panel.

**UNITED STATES GYPSUM CO** — Types STRUCTO-CRETE, USGSP

1B. **Floor Topping Mixture\*** — Min 3/4 in. thickness of floor topping mixture having a minimum compressive strength of 1800 psi. Refer to manufacturer's instructions accompanying the material for specific mix design.

**UNITED STATES GYPSUM CO** — Types LRK, HSLRK, CSD

**Floor Mat Materials\*** — (Optional) - Floor mat material loose laid over the subfloor. Refer to manufacturer's instructions regarding the minimum thickness of floor topping over each floor mat material.

**UNITED STATES GYPSUM CO** — Types SAM, LEVELROCK® Brand Sound Reduction Board, LEVELROCK® Brand Floor Underlayment SRM-25

**Alternate Floor Mat Materials\*** — (Optional) - Floor mat material nom 3/8 in. thick loose laid over the subfloor. Floor topping thickness a min 3/4 in. over the floor mat.

**GRASSWORX L L C** — Type SC50

2. **Steel Joists** — Channel-shaped, min 10 in. deep with min 1-5/8 in. wide flanges and 1/2 in. long stiffening flanges. Fabricated from min No. 16 MSG galv steel. Min yield strength of 50,000 psi. Joists spaced max 24 in. OC. Supplied with appropriate rim tracks of same size and gauge.

2A. **Steel Joists** — (Not Shown) -As an alternate to Item 2 - For maximum clear spans not exceeded 8 ft. Channel-shaped, min 6 in. deep with min 1-9/16 in. wide flanges and 3/8 in. long stiffening flanges. Fabricated from min No. 18 MSG galv steel. Min yield strength of 33,000 psi. Joists spaced max 24 in. OC. Supplied with appropriate rim tracks of same size and gauge.

2B. **Steel Joists** — (Not Shown) -As an alternate to Item 2 - Channel-shaped, min 8 in. deep with min 1-9/16 in. wide flanges and 3/8 in. long stiffening flanges. Fabricated from min No. 16 MSG galv steel. Min yield strength of 33,000 psi. Joists spaced max 24 in. OC. Supplied with appropriate rim tracks of same size and gauge.

2C. **Steel Joists** — (Not shown) - As an alternate to item 2 - The joists are channel-shaped, 10 in. min depth. Joists are fabricated from min No. 16 MSG galv steel. Joists spaced max 24 in. OC. Joists attached to rim joist with a minimum of three #10 3/4 in. long self-drilling screws at the rim track clip to the outside of the web joist, and a #10 1/2 in. long screw through the top and bottom flange of the joists to the top and bottom flange of the rim track. At rim joist splices bearing on supports, rim joists are connected using an overlapping section of a 12 in. long splice plate (a joist piece), with a minimum of six 3/4 in. long self-drilling #10 screws to each rim piece. For use with item 3C.

**CALIFORNIA EXPANDED METAL PRODUCTS CO** — Type SSCJ floor joists, SSRT rim joists or Type SSTT rim joists. When Type SSTT rim joists are used, secured to preformed clip tabs in accordance with manufacturers installation instructions.

2D. **Structural Steel Members\*** — (Not Shown) - As an alternate to Item 2, 2a, 2b and 2c - Pre-fabricated light gauge steel truss system consisting of cold-formed, galv steel chord and web sections. Trusses fabricated in various sizes, depths and from various steel thicknesses spaced a maximum of 24 in. OC.

**TRUSSTEEL, DIV OF ITW BUILDING COMPONENTS INC** — TrusSteel

2E. **Structural Steel Members\*** — JoistRite channel-shaped joists, min 9-1/4 in. deep with min 2 in. wide flanges and 3/4 in. long stiffening flanges. The web of each joist is provided with 3/4 in. deep lip-reinforced trapezoidal cutouts as shown in the illustration. JoistRite rim track, min 9-3/8 in. deep with min 1-1/2 in. top flange and min 2-5/16 in. bottom flange. The joists and rim tracks are fabricated from min 16 MSG galv steel. Joists spaced max 24 in. OC. Floor joists attached to rim track using channel-shaped steel web stiffeners. At rim track splices bearing on supports, rim tracks are connected using an overlapping section of a 12 in. long splice plate, with four 3/4 in. long self-drilling #10 screws to each rim piece.

**MARINO/WARE, DIV OF WARE INDUSTRIES INC** — Type JR JoistRite floor joists, Type JT JoistRite rim track.

3. **Clip Angles (Not shown)** — For use with 10 in. deep joists (Item 2). No. 16 MSG, 9-3/4 in. long steel angles with 2 in. legs. Secured to track and joist with eight No.10, 3/4 in. long, self drilling, hex head screws, located 1 in. from each end of clip angle, with the other two screws on each leg evenly spaced. Only one clip angle per joist end.

3A. **Clip Angles** — (Not Shown) - As an alternate to Item 3, for use with 6 or 8 in. deep joists (Item 2A or 2B). No. 16 MSG, 5-1/2 in. long steel angles with 1-1/2 in. legs for 6 in. deep joists and No. 18 MSG, 7-1/4 in. long steel angles with 1-1/2 in. legs for 8 in. deep joists. Secured to track and joist with six No.10, 3/4 in. long, self-drilling, hex head screws, located 1 in. from each end of the clip angle and at the centerline. Only one clip angle per joist end.

4. **Joist Bridging** — For use with Items 2 and 2B - Installed immediately after joists are erected and before construction loads are applied. The bridging consisting of joist sections cut to length and placed between outer supports, adjacent to openings and at mid span with 8 ft OC max spacing. Bridging channels are screw-attached at each end to joist web using angle clips. V-bracing of 1-1/2 in. by 20-ga galvanized steel is screw-attached to bottom joist flange between bridging channels.

4A. **Joist Bridging** — (Not Shown) - For use with Items 2A and 2B - 1-1/2 in. wide strips formed from 20 MSG - The structural bridging is installed perpendicular to and on the bottom surface of the joists at mid-span with one #10 x 3/4 in. long hex head steel screw at each interface.

4B. **Joist Bridging** — (Not Shown) - For use with Item 2A - Installed immediately after joists are erected and before construction loads are applied. The bridging consisting of rim track sections cut to length, with two 4 in. long folded back flanges, and placed between outer supports, adjacent to openings and at mid span with 10 ft OC max spacing. Bridging channels are screw-attached to each of the four top and bottom joist flanges with two No. 8 by 1/2 in. long wafer head steel screws.

4C. **Joist Bridging** — Not shown — For use with Item 2C. Installed immediately after joists are erected and before construction loads are applied. The structural bridging, Type CEMCO Sure Bridging, consisting of No. 18 MSG galv steel, 2-1/2 in. wide by 25-1/2 in. long with 1-5/16 in. long legs structural bridging staggered between the steel joists and attached to the bottom joist flange with two #10 1/2 in. long self-drilling screws at each end tab of bridging. Solid bridging consisting of cut to length joist sections placed between outer joists and at center joist with 8 ft OC max spacing. Solid bridging is seated in the structural bridging and is screw-attached at joist web using Type CEMCO Sure-Support Clips (1-1/2 in. by 1-1/2 in. by 7 in. long, 16 MSG, min 50 ksi support clip) with three #10 3/4 in. long self-drilling screws per leg on one side and the other side with Type CEMCO Sure-Support Clips (4 in. by 1-1/2 in. by 7 in. long, 16 MSG, min 50 ksi support clip) with three #10 3/4 in. long self-drilling screws per leg.

4D. **Bridging** — (Not Shown)—For use with Item 2D - Location of lateral bracing for truss chord and web sections to be specified on truss engineering.

4E. **Blocking & Bridging** — Not shown - For use with Item 2E - Installed before construction loads are applied. The blocking consists of JoistRite solid blocking placed between each joist. Blocking attached to the top and bottom joist flanges with one #10 3/4 in. long self-drilling screw at each end tab of blocking. Blocking is fabricated from min 18 MSG galv steel, min 1-15/16

in. flanges, having the same depth as the joists. In addition, bridging consists of 1/2 in. by 1-1/2 in. cold-rolled channel, min No. 16 GA, attached to the bottom flanges of the joists and blocking. Cold-rolled channel attached to each blocking bottom flange with four #10 3/4 in. long self-drilling screws and to joist bottom flange with two screws.

4F. **Web Stiffeners** — Not shown — For use with Item 2E - JoistRite web stiffeners, min 3-5/8 in. wide with min 9/16 in. flange and min 1-1/4 in. flange, having the same depth as the joists. Fabricated from min 16 MSG galv steel. Secured to each joist and track with #10, 3/4 in. long self-drilling screws.

5. **Ceiling Joists** — Channel shaped sections, min 3-1/2 in. deep with min 1-9/16 in. flanges and 9/16 in. stiffening flanges. Joists fabricated from min No. 18 MSG painted or galv steel with a min 50 ksi yield strength. Joists designed in accordance with the American Iron and Steel Institute specifications adopted August 1986. Joists spaced max 16 in. OC. A separation of minimum 2 inches shall be maintained between the top of the ceiling joists and the bottom of the floor joists.

6. **Ceiling Joists Track** — Cold formed channels min 3-5/8 in. deep with min 1-1/4 in. flanges. Ceiling tracks fabricated from min No. 18 MSG painted or galv steel, to provide supporting surface between ceiling joists (Item 8) and at periphery structural support elements. Ends of ceiling joists secured to ceiling tracks with 1 in. long, 1/8 in. fillet welds at top and bottom joist flanges.

7. **Ceiling Joist Bridging** — Continuous channel shaped sections, min 2-1/2 in. deep with min 1-9/16 in. flanges and 1/2 in. stiffening flanges. Bridging fabricated from min No. 18 MSG painted or galv steel. Bridging provided on top of ceiling joists at mid-span. Bottom flange of bridging secured to top flange of each ceiling joist with 1 in. long, 1/8 in. fillet weld.

8. **Insulation - Batts and Blankets\*** — (Optional) - Glass fiber batt insulation draped over the top flanges of the 3-1/2 in. deep "C" ceiling joists (Item 5), or draped over the resilient channels (Item 9), or supported between the "C" channel (Item 2) floor joists, just below the structural cement fiber units (Item 1), Any glass fiber batt insulation bearing the UL Classification Marking for Surface Burning Characteristics may be used. See Batts and Blankets (BKNV) category in the Building Materials Directory for names of manufacturers.

9. **Resilient Channels** — Formed of No. 25 MSG galv steel, 1/2 in. deep, spaced max 12 in. OC, perpendicular to ceiling joists (Item 5). Channel splices located beneath joists and overlapped 4 in. Channels secured to each joist with one 1/2 in. long Type S-12 low profile steel screw. Two channels spaced 6 in. OC, oriented opposite each gypsum board end joint as shown on the illustration above. Additional channels shall extend min 6 in. beyond each side edge of board.

9A. **Steel Framing Members\*** — (Optional, Not Shown) — As an alternate to Item 9 — Furring channels and Steel Framing Members as described below:

a. **Furring channels** — Formed of No. 25 MSG galv steel, 2-3/8 in. wide by 7/8 in. deep, spaced 12 in. OC, perpendicular to joists. Channel secured to joists as described in Item b. Ends of adjoining channels overlapped 6 in. and tied together with double strand of No. 18 SWG galv steel wire near each end of overlap. Additional channels shall be positioned so that the distance from the end of the board to the center of the first channel is 3 in. and from the board end to the center of the next channel is 12 in.

b. **Steel Framing Members\*** — Used to attach furring channels (Item a) to joists (Item 2). Clips spaced 48 in. OC and secured to the bottom chord of joists with min 1-5/8 in. long No. 8 self-drilling, self-tapping, bugle, flat or hex head screw through the center grommet. Furring channels are friction fitted into clips. Additional clips required to hold furring channel that supports the gypsum board butt joints.

**PLITEQ INC** — Type Genie Clip

9B. **Alternate Steel Framing Members\*** — (Optional, Not Shown) — As an alternate to Items 9 and 9A, furring channels and Steel Framing Members as described below.

a. **Furring channels** — Formed of No. 25 MSG galv steel. 2-9/16 in. or 2-23/32 in. wide by 7/8 in. deep, spaced 12 in. OC, perpendicular to joists. Channels secured to joists as described in Item b. Ends of adjoining channels overlapped 6 in. and tied together with double strand of No. 18 SWG galv steel wire near each end of overlap.

b. **Steel Framing Members\*** — Used to attach furring channels (Item a) to the steel joists (Item 2). Clips spaced a max of 48 in. OC. RSIC-1 and RSIC-1 (2.75) clips secured to alternating joists with No. 8 x 2-1/2 in. coarse drywall screw through the center grommet. Furring channels are friction fitted into clips. RSIC-1 clips for use with 2-9/16 in. wide furring channels. RSIC-1 (2.75) clips for use with 2-23/32 in. wide furring channels. Adjoining channels are overlapped as described in Item a. As an alternate, ends of adjoining channels may be overlapped 6 in. and secured together with two self-tapping No. 6 framing screws, min. 7/16 in. long at the midpoint of the overlap, with one screw on each flange of the channel. Additional clips required to hold furring channel that supports the wallboard butt joints, as described in Item 10.

**PAC INTERNATIONAL L L C** — Types RSIC-1 or RSIC-1 (2.75)

10. **Gypsum Board\*** — One layer of nom 5/8 in. thick by 48 in. wide gypsum panels installed with long dimension perpendicular to resilient/furring channels. Gypsum panels secured to resilient/furring channels with 1 in. long Type S bugle-head screws spaced 8 in. OC, with screws located 4 in. from and on each side of the gypsum panel midspan, and 1-1/2 in. from side edges of the board. End joints secured to both resilient/furring channels as shown in end joint detail. When **Steel Framing Members** (Item 9A or 9B) are used, the butt joints in the gypsum board shall be supported by two furring channels. The two furring channels shall be spaced approximately 3-1/2 in. OC, and be attached to underside of the joist with one RSIC-1, RSIC-1 (2.75) or Genie clip at each end of the channel.

**CGC INC** — Types C, IP-X2, IPC-AR, ULIX

**UNITED STATES GYPSUM CO** — Types C, IP-X2, IPC-AR, ULIX

**USG BORAL DRYWALL SFZ LLC** — Type C

**USG MEXICO S A DE C V** — Types C, IP-X2, IPC-AR

11. **Finishing System - (Not Shown)** — Vinyl, dry or premixed joint compound, applied in two coats to joints and screw-heads. Nom 2 in. wide paper tape embedded in first layer of compound over all joints. As an alternate, nom 3/32 in. thick veneer plaster may be applied to the entire surface of gypsum panels.

**\* Indicates such products shall bear the UL or cUL Certification Mark for jurisdictions employing the UL or cUL Certification (such as Canada), respectively.**

Last Updated on 2019-11-12

---

The appearance of a company's name or product in this database does not in itself assure that products so identified have been manufactured under UL's Follow-Up Service. Only those products bearing the UL Mark should be considered to be Certified and covered under UL's Follow-Up Service. Always look for the Mark on the product.

UL permits the reproduction of the material contained in the Online Certification Directory subject to the following conditions: 1. The Guide Information, Assemblies, Constructions, Designs, Systems, and/or Certifications (files) must be presented in their entirety and in a non-misleading manner, without any manipulation of the data (or drawings). 2. The statement "Reprinted from the Online Certifications Directory with permission from UL" must appear adjacent to the extracted material. In addition, the reprinted material must include a copyright notice in the following format: "© 2020 UL LLC"