



Expanding Your Solutions



**Sure-Span<sup>®</sup>**

Light Gauge Steel Floor Joist System  
Product Guide 2019

# Table of Contents

## Introduction

Sure-Span® Steel Floor Joist System ..... 3

## Overview

Product Information for SSCJ (Joists) and SSTT (Rim Track) ..... 4  
Steel Thickness/Punch-Out Dimensions ..... 5  
Flange Joist Bridging ..... 6  
Definitions of Structural Properties Notations ..... 7

## Tables

Sure-Span® Joist | Structural Properties and Load Capacities: 7.25" to 14" Web ..... 8  
Sure-Span® Rim Track | Structural Properties and Load Capacities ..... 9  
Joist Span | 10" Minimum Hole Offset From Bearing Support ..... 10–18  
Sure-Span® Joists | Allowable Web Crippling Capacities ..... 19

The technical information supplied by this publication is intended ONLY to assist the professional architects and/or engineers in the selection or analysis of CEMCO Sure-Span® Cold-Formed Steel Floor Joist System, and does not replace the professional judgments of a qualified architect and/or engineer. Because physical properties vary from competitive products, information from this publication should be used ONLY with CEMCO stud and track sections. CEMCO assumes no liability for failure resulting from the use of its drawings, computations, or for failure resulting from the use of alternative materials, or improper application or installation. Although the data found herein are derived from the sources believed to be reliable, no warranty, express or implied is made to the adequacy, completeness, legality, reliability, or usefulness of any information.

ALL WARRANTIES OF ANY KIND, EXPRESS OR IMPLIED, INCLUDING BUT NOT LIMITED TO THE IMPLIED WARRANTIES OF MERCHANTABILITY AND FITNESS FOR A PARTICULAR PURPOSE ARE DISCLAIMED.

# Introduction

## Sure-Span® Steel Floor Joist System

CEMCO's Sure-Span® steel floor joist system is a patented, tested, and approved solution for commercial, mid-rise, and residential floor framing assemblies. Sure-Span floor joists are manufactured with extra-large openings (punch-outs) to allow for mechanical, electrical, and plumbing access without damaging the structural integrity of the floor framing system commonly seen with typical c-shaped joists that require cutting of the joist to accommodate these lines. Sure-Span provides long and sturdy floor spans, along with fire-resistant and sound-reducing solutions for architects, engineers, and developers.

## Material Specifications for SSCJ (Joists) & SSTT (Rim-Track)

All CEMCO Sure-Span products are manufactured from hot-dipped galvanized steel meeting or exceeding the following ASTM, AISI, and UL standards.

- C955 (Structural Product)
- C1007 (Installation)
- A924/A924M (Coating)
- A653/A653M (Steel)
- A1003/A1003M (Steel)
- AISI S100-2016: Design of Cold-Formed Steel Structural Members
- UL® testing standards and UL® Certified Products and Follow-Up Service (FUS)
- UL G556, G557, G560, G565, G574, G580, G588, G595, H503, H508, P546, P561, P562
- US Patent No. 20090064611A1

## LEED v4 for Building & Design Construction

- MR Prerequisite: Construction and Demolition Waste Management Planning.
- MR Credit: Construction and Demolition Waste Management.
- MR Credit: Building Product Disclosure and Optimization – Sourcing of Raw Materials, Option 2.
- MR Credit: Building Product Disclosure and Optimization – Environmental Product Declarations, Options 1 & 2.
- MR Credit: Building Product Disclosure and Optimization – Material Ingredients, Option 1.
- MR Credit: Building Life-Cycle Impact Reduction, Option 4.

## California's Proposition 65 Warning

California's Safe Drinking Water and Toxic Enforcement Act of 1986 – commonly referred to as Proposition 65 ("Prop 65") (27 Cal. Code Reg. § 25600, et seq.) – has recently changed, requiring manufacturers to provide a warning based on its knowledge about the presence of one or more of the almost 900 listed chemicals which are known to the State of California to cause cancer and birth defects, or other reproductive harm. With a few exceptions, manufacturers operating in the state of California as well as those entities who distribute, import, package, and/or supply products into the State of California are now required provide a "clear and reasonable" warning to consumers that their products may contain one or more of these listed chemicals or compounds. The complete list is available at [www.P65Warnings.ca.gov](http://www.P65Warnings.ca.gov).

In compliance with the new requirements, we are notifying each of our customers that CEMCO products contain Nickel (metallic) and/or other chemicals listed which are known to the State of California to cause cancer and birth defects or other reproductive harm. Safety data sheets from our major suppliers are available from CEMCO on our website at [www.cemcosteel.com](http://www.cemcosteel.com).



CEMCO assumes no liability for failure resulting from the use of its drawings, or for failure resulting from the use of alternate materials, or improper application or installation. This drawing is supplied solely to assist in the selection and application of CEMCO products. This drawing is generic in nature and should not be used in design or construction without an independent evaluation by a qualified Architect or Engineer of Record.

# Product Information for SSCJ (Joists) & SSTT (Rim Track)

- **Thicknesses ranging from 43 mils (18 ga.) to 97 mils (12 ga.)**
- **SSCJ Joists are available in the following configurations:**
  - 7-1/4", 8", 9-1/4", & 11-1/4" depths with 1-3/4" flanges
  - 10", 12", & 14" depths with 2" flanges
  - First punch-out is located at 18" from one end, and 48" on-center after that
- **SSTT Rim Tracks are available in the following configurations:**
  - 7-1/4", 8", 9-1/4", 10", 11-1/4", 12", & 14" web depths with 2" legs
  - Pre-Spaced/Pre-Attached clips at 12", 16", or 24" on-center
  - All Rim Tracks available in either 16' or 32' lengths
- **Grades of Steel**
  - $F_y$  (min yield strength) = 33 KSI
    - > 43 mils (18 ga.)
      - ~ SSCJ Joists and SSTT Rim Tracks
      - ~ SB Sure-Bridge clips
      - ~ Corner/Utility clips
  - $F_y$  (min yield strength) = 50 KSI
    - > 54 mils (16 ga.)
      - ~ SSCJ Joists and SSTT Rim Tracks
      - ~ Corner/Utility clips
    - > 68 mils (14 ga.)
      - ~ SSCJ Joists and SSTT Rim Tracks
      - ~ Corner/Utility clips
    - > 97 mils (12 ga.)
      - ~ SSCJ Joists and SSTT Rim Tracks
      - ~ Corner/Utility clips

## Steel Thickness

Minimum Base Metal Thickness (mil)	Design Thickness (in) <sup>1</sup>	Minimum Thickness (in) <sup>1,2</sup>	Color Code
43	0.0451" (1.15 mm)	0.0428" (1.09 mm)	Yellow
54	0.0566" (1.44 mm)	0.0538" (1.37 mm)	Green
68	0.0713" (1.81 mm)	0.0677" (1.72 mm)	Orange
97	0.1017" (2.58 mm)	0.0966" (2.45 mm)	Red

1) Uncoated steel thickness. Thickness is for carbon sheet steel.

2) Minimum thickness represents 95% of the design thickness and is the minimum acceptable thickness delivered to the job site, based on Section A4.3 of the AISI S100-2012.

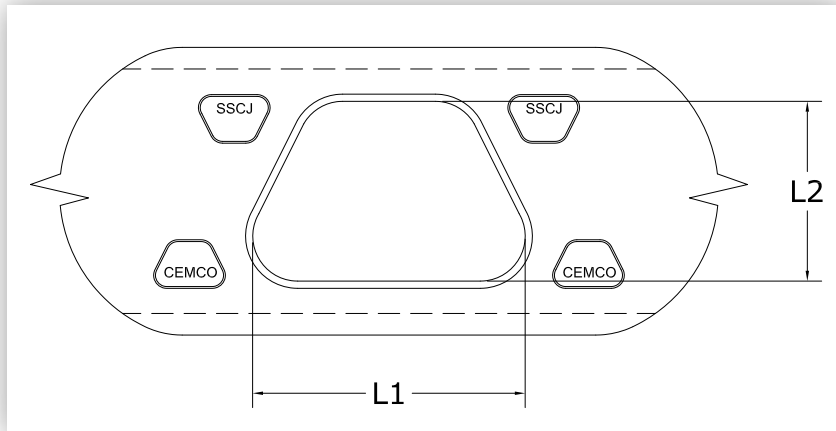

Detail of SSCJ Punch-Outs

## SSCJ Punch-Out Dimensions

Section	L1 (in)	L2 (in)	Spacing Between Punch-Outs (in)
725SSCJ175 - XX	7-5/32	4-1/4	48
800SSCJ175 - XX	7-5/32	4-1/4	48
925SSCJ175 - XX	9-15/32	6-1/4	48
1000SSCJ200 - XX	9-15/32	6-1/4	48
1125SSCJ175 - XX	9-15/32	6-1/4	48
1200SSCJ200 - XX	9-1/32	8	48
1400SSCJ200 - XX	11-1/16	10	48

CEMCO assumes no liability for failure resulting from the use of its drawings, or for failure resulting from the use of alternate materials, or improper application or installation. This drawing is supplied solely to assist in the selection and application of CEMCO products. This drawing is generic in nature and should not be used in design or construction without an independent evaluation by a qualified Architect or Engineer of Record.

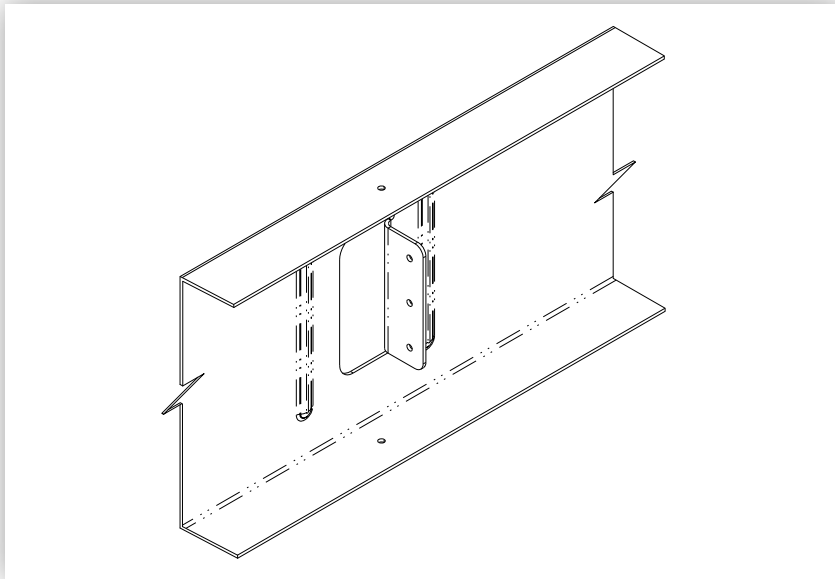

Detail of SST

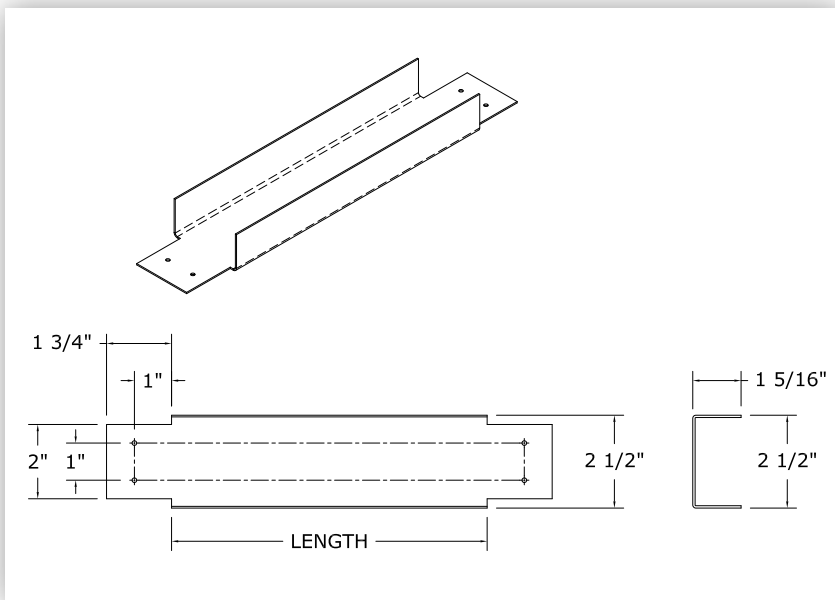

Detail of Sure Bridging

### Sure-Bridging for 1-3/4" Flange Joists

Thickness (mils)	Part No.	Length	Joist Spacing
43	175SB4312	10"	12" O.C.
	175SB4316	14"	16" O.C.
	175SB4324	22"	24" O.C.

### Sure-Bridging for 2" Flange Joists

Thickness (mils)	Part No.	Length	Joist Spacing
43	200SB4312	9-3/4"	12" O.C.
	200SB4316	13-3/4"	16" O.C.
	200SB4324	21-3/4"	24" O.C.

CEMCO assumes no liability for failure resulting from the use of its drawings, or for failure resulting from the use of alternate materials, or improper application or installation. This drawing is supplied solely to assist in the selection and application of CEMCO products. This drawing is generic in nature and should not be used in design or construction without an independent evaluation by a qualified Architect or Engineer of Record.

## Definitions of Structural Properties Notations

Symbol	Definition
$I_x$	Full Moment of Inertia about the X axis (strong axis)
$I_y$	Full Moment of Inertia about the Y axis (weak axis)
$S_x$	Full Section Modulus about the X axis
$S_y$	Full Section Modulus about the Y axis
$R_x, R_y$	Radius of Gyration about the X and Y axis, respectively
$X_o$	Distance between Centroid and Shear Center
$J$	St. Venant's Torsion Constant

Symbol	Definition
$C_w$	Torsion Warping Constant
$R_o$	Polar Radius of Gyration about the Shear Center
$\beta$	Torsional-Flexural Constant
$A_N$	Cross-sectional Area at Punch-out
$I_{xN}$	Moment of Inertia at Punch-out about the X axis
$M_{ALL}$	Allowable Moment for fully braced joist
$V_{ALL}$	Allowable shear

### Notes

- The minimum yield strength,  $F_y$ , is 33 ksi for 18 gauge and 50 ksi for 16, 14, and 12 gauge steel.
- Punch-out Depth = 4.25" (web depth 7.25", 8")  
 = 6.25" (web depth 9.25", 10" and 11.25")  
 = 8" (web depth 12")  
 = 10" (web depth 14")
- For Allowable Stress Design (ASD) method, use a factor of safety of 1.67 for both moment and shear capacities. These factors of safety are as per AISI S100-2016.
- Allowable moment,  $M_{ALL}$ , and shear,  $V_{ALL}$ , capacities for joists are obtained by applying factors of safety to the least nominal capacities (between full and net capacities).



Section Designation	Dim.		Gross Section Properties										Net Section Properties (at Punch-Outs)					Allowable Capacities				Effective Section Properties				
	Flange Width, w (in)	Design Thickness, t (in)	Weight (plf)	Area (in <sup>2</sup> )	I <sub>x</sub> (in <sup>4</sup> )	I <sub>y</sub> (in <sup>4</sup> )	S <sub>x</sub> (in <sup>3</sup> )	S <sub>y</sub> (in <sup>3</sup> )	R <sub>x</sub> (in)	R <sub>y</sub> (in)	Torsional Properties					A <sub>n</sub> (in <sup>2</sup> )	I <sub>xn</sub> (in <sup>4</sup> )	r <sub>xn</sub> (in)	I <sub>yn</sub> (in <sup>4</sup> )	r <sub>yn</sub> (in)	M <sub>ap</sub> (k-in)	V <sub>ap</sub> (k)	M <sub>af</sub> (k-in)	V <sub>af</sub> (k)	S <sub>xe</sub> (in <sup>3</sup> )	S <sub>xen</sub> (in <sup>3</sup> )
											X <sub>c</sub> (in)	J x 1000 (in <sup>4</sup> )	C <sub>w</sub> (in <sup>6</sup> )	R <sub>o</sub> (in)	β											
<b>7.25" Depth</b>																										
725SSCJ175-43	1.75	0.0451	1.826	0.537	3.998	0.225	1.103	0.175	2.728	0.647	-1.204	0.364	2.468	3.051	0.844	0.376	3.878	3.213	0.160	0.653	17.426	0.900	19.679	1.163	0.996	1.056
725SSCJ175-54	1.75	0.0566	2.276	0.700	4.951	0.275	1.366	0.214	2.719	0.641	-1.190	0.715	3.003	3.037	0.846	0.466	4.796	3.209	0.195	0.648	32.771	1.637	37.575	2.316	1.255	1.311
725SSCJ175-68	1.75	0.0713	2.841	0.836	6.124	0.334	1.689	0.260	2.707	0.633	-1.173	1.416	3.626	3.017	0.849	0.577	5.920	3.203	0.236	0.64	52.100	1.931	48.844	4.679	1.631	1.633
<b>8.00" Depth</b>																										
800SSCJ175-43	1.75	0.0451	1.941	0.571	5.069	0.231	1.267	0.176	2.980	0.636	-1.149	0.387	3.047	3.256	0.875	0.410	4.950	3.471	0.175	0.654	24.153	1.319	21.978	1.051	1.112	1.222
800SSCJ175-54	1.75	0.0566	2.421	0.712	6.282	0.282	1.571	0.215	2.970	0.630	-1.136	0.760	3.710	3.242	0.877	0.508	6.127	3.472	0.214	0.648	45.750	2.433	42.027	2.091	1.404	1.528
800SSCJ175-68	1.75	0.0713	3.023	0.889	7.777	0.344	1.944	0.262	2.958	0.622	-1.118	1.507	4.484	3.222	0.880	0.631	7.573	3.466	0.259	0.641	63.683	2.934	54.937	4.220	1.835	1.893
<b>9.25" Depth</b>																										
925SSCJ175-54	1.75	0.0566	2.661	0.783	8.951	0.293	1.935	0.217	3.382	0.612	-1.056	0.836	5.090	3.595	0.914	0.466	8.218	4.200	0.195	0.648	43.982	1.637	49.446	1.799	1.652	1.759
925SSCJ175-68	1.75	0.0713	3.326	0.978	11.095	0.357	2.399	0.264	3.368	0.604	-1.039	1.658	6.159	3.576	0.916	0.577	10.153	4.195	0.236	0.64	69.243	1.931	65.091	3.627	2.174	2.195
925SSCJ175-97	1.75	0.1017	4.666	1.372	15.297	0.472	3.308	0.350	3.339	0.587	-1.004	4.731	8.056	3.535	0.919	0.794	13.895	4.183	0.309	0.624	105.47	2.368	97.422	10.708	3.254	3.004
<b>10.00" Depth</b>																										
1000SSCJ200-54	2.00	0.0566	2.902	0.853	11.542	0.411	2.308	0.266	3.677	0.694	-1.196	0.911	8.211	3.929	0.907	0.537	10.809	4.488	0.294	0.74	62.946	2.433	56.383	1.660	1.883	2.102
1000SSCJ200-68	2.00	0.0713	3.629	1.067	14.327	0.502	2.866	0.324	3.664	0.686	-1.178	1.809	9.973	3.909	0.909	0.666	13.385	4.483	0.357	0.733	88.863	2.934	76.371	3.345	2.551	2.677
1000SSCJ200-97	2.00	0.1017	5.098	1.500	19.813	0.669	3.963	0.433	3.635	0.668	-1.142	5.170	13.154	3.868	0.913	0.921	18.411	4.471	0.473	0.716	127.030	3.798	114.860	9.862	3.836	3.682
<b>11.25" Depth</b>																										
1125SSCJ175-54	1.75	0.0566	3.046	0.896	14.516	0.307	2.581	0.220	4.025	0.585	-0.952	0.957	7.842	4.177	0.948	0.579	13.783	4.879	0.238	0.641	67.472	3.760	61.281	1.471	2.047	2.254
1125SSCJ175-68	1.75	0.0713	3.811	1.121	18.023	0.373	3.204	0.268	4.010	0.577	-0.935	1.900	9.500	4.158	0.949	0.720	17.081	4.872	0.289	0.634	87.802	4.605	81.336	2.961	2.717	2.933
1125SSCJ175-97	1.75	0.1017	5.358	1.576	24.935	0.494	4.433	0.355	3.978	0.560	-0.902	5.433	12.459	4.117	0.952	0.997	23.533	4.857	0.381	0.618	144.880	6.181	124.190	8.714	4.148	4.127
<b>12.00" Depth</b>																										
1200SSCJ200-54	2.00	0.0566	3.287	0.967	18.062	0.429	3.010	0.269	4.323	0.666	-1.087	1.032	12.315	4.507	0.942	0.551	16.312	5.442	0.301	0.74	78.565	2.698	57.295	1.102	2.292	2.624
1200SSCJ200-68	2.00	0.0713	4.114	1.210	22.454	0.524	3.742	0.328	4.308	0.658	-1.070	2.050	14.973	4.487	0.943	0.684	20.215	5.437	0.366	0.732	111.840	3.268	93.622	2.770	3.127	3.369
1200SSCJ200-97	2.00	0.1017	5.790	1.703	31.140	0.699	5.190	0.438	4.276	0.641	-1.036	5.871	19.795	4.446	0.946	0.947	27.854	5.425	0.485	0.716	160.150	4.274	143.110	8.145	4.78	4.642
<b>14.00" Depth</b>																										
1400SSCJ200-68	2.00	0.0713	4.600	1.353	32.997	0.541	4.714	0.331	4.939	0.632	-0.981	2.292	21.157	5.075	0.963	0.684	28.282	6.430	0.366	0.732	134.120	3.268	110.840	2.364	3.702	4.040
1400SSCJ200-97	2.00	0.1017	6.481	1.906	45.872	0.721	6.553	0.442	4.905	0.615	-0.948	6.572	28.014	5.034	0.965	0.947	38.999	6.419	0.485	0.719	192.200	4.274	171.410	6.938	5.725	5.571

Notations

- I<sub>x</sub> Full Moment of Inertia about the X axis
- I<sub>y</sub> Full Moment of Inertia about the Y axis
- S<sub>x</sub> Full Section Modulus about the X axis
- S<sub>y</sub> Full Section Modulus about the Y axis
- R<sub>x</sub>, R<sub>y</sub> Radius of Gyration about the X and Y axis, respectively
- X<sub>o</sub> Distance between Centroid and Shear Center
- J St. Venant's Torsion Constant
- C<sub>w</sub> Torsional Warping Constant
- R<sub>o</sub> Polar Radius of Gyration about the Shear Center
- β Torsional-Flexural Constant
- A<sub>n</sub> Net Area at Punch-out
- I<sub>xn</sub>, I<sub>yn</sub> Moment of Inertia at Punch-out about the X axis
- r<sub>xn</sub>, r<sub>yn</sub> Net Section Radius of Gyration about the X and Y axes, respectively
- M<sub>ap</sub> Fully-braced Allowable Moment at Punch-out
- V<sub>ap</sub> Allowable Shear at Punch-out
- M<sub>af</sub> Fully-braced Allowable Moment at Full Section
- V<sub>af</sub> Allowable Shear at Full Section
- S<sub>xe</sub> Effective Section Modulus about the X axis at Full Section
- S<sub>xen</sub> Effective Section Modulus about the X axis at Net Section

Notes

1. The yield strength, F<sub>y</sub>, is 33 ksi for 18 gauge and 50 ksi for 16, 14, and 12 gauge steel.
2. Tabulated weight values based on 4'-0" o.c. punch-out progression.
3. Punch-out Depth = 4.25" (web depth 7.25" and 8")  
6.25" (web depth 9.25", 10", and 11.25")  
8.00" (web depth 12")  
10.00" (web depth 14")
4. For Allowable Stress Design (ASD) method, factors of safety of 1.67 and 1.6 respectively, are used for moment and shear capacities as per AISI S100-2016.

Section Designation	Dimensions			Gross Section Properties												Capacities				
	H (in)	Gauge	t (in)	Weight (plf)	Area (in <sup>2</sup> )	I <sub>x</sub> (in <sup>4</sup> )	I <sub>y</sub> (in <sup>4</sup> )	S <sub>x</sub> (in <sup>3</sup> )	S <sub>y</sub> (in <sup>3</sup> )	R <sub>x</sub> (in)	R <sub>y</sub> (in)	Torsional Properties					M <sub>at</sub> (k-in)	V <sub>at</sub> (k)	M <sub>af</sub> (k-in)	V <sub>af</sub> (k)
												X <sub>o</sub> (in)	J x 1000 (in <sup>4</sup> )	C <sub>w</sub> (in <sup>6</sup> )	R <sub>o</sub> (in)	β				
<b>7.25" Depth</b>																				
725SSTT200-43	7.340	18	0.0451	1.636	0.481	3.484	0.117	0.949	0.388	2.691	0.494	-0.793	0.326	1.139	2.848	0.922	11.086	0.638	12.125	1.149
725SSTT200-54	7.363	16	0.0566	2.050	0.603	4.367	0.146	1.186	0.476	2.691	0.492	-0.791	0.644	1.418	2.848	0.923	21.318	0.999	23.330	2.279
725SSTT200-68	7.393	14	0.0713	2.576	0.758	5.490	0.182	1.485	0.582	2.692	0.490	-0.787	1.284	1.765	2.847	0.923	31.451	1.569	34.359	4.584
<b>8.00" Depth</b>																				
800SSTT200-43	8.090	18	0.0451	1.751	0.515	4.419	0.120	1.093	0.422	2.929	0.482	-0.754	0.349	1.432	3.063	0.939	12.624	0.737	13.718	1.039
800SSTT200-54	8.113	16	0.0566	2.194	0.645	5.539	0.149	1.366	0.517	2.930	0.481	-0.751	0.689	1.782	3.062	0.940	24.267	1.156	26.388	2.061
800SSTT200-68	8.143	14	0.0713	2.758	0.811	6.963	0.186	1.710	0.631	2.930	0.478	-0.748	1.375	2.218	3.061	0.940	35.798	1.822	38.868	4.143
<b>9.25" Depth</b>																				
925SSTT200-54	9.363	16	0.0566	2.435	0.716	7.902	0.153	1.688	0.584	3.322	0.463	-0.694	0.765	2.494	3.425	0.959	28.935	1.361	31.290	1.777
925SSTT200-68	9.393	14	0.0713	3.061	0.900	9.932	0.191	2.115	0.711	3.321	0.461	-0.691	1.526	3.104	3.423	0.959	42.704	2.149	46.111	3.570
925SSTT200-97	9.453	12	0.1017	4.348	1.279	14.096	0.266	2.982	0.947	3.320	0.456	-0.684	4.409	4.314	3.420	0.960	76.736	4.330	82.570	10.464
<b>10.00" Depth</b>																				
1000SSTT200-54	10.113	16	0.0566	2.676	0.787	10.301	0.228	2.037	0.740	3.618	0.538	-0.820	0.840	4.300	3.749	0.952	31.363	0.921	34.953	1.641
1000SSTT200-68	10.143	14	0.0713	3.364	0.989	12.950	0.284	2.554	0.905	3.618	0.536	-0.816	1.677	5.361	3.747	0.953	46.460	1.449	51.663	3.296
1000SSTT200-97	10.203	12	0.1017	4.781	1.406	18.393	0.397	3.605	1.217	3.617	0.531	-0.810	4.848	7.479	3.744	0.953	84.119	2.896	93.086	9.655
<b>11.25" Depth</b>																				
1125SSTT200-54	11.363	16	0.0566	2.820	0.829	12.870	0.159	2.265	0.688	3.939	0.438	-0.619	0.886	3.913	4.012	0.976	34.449	1.115	38.408	1.456
1125SSTT200-68	11.393	14	0.0713	3.546	1.043	16.174	0.198	2.839	0.835	3.938	0.435	-0.616	1.767	4.871	4.010	0.976	50.972	1.760	56.710	2.923
1125SSTT200-97	11.453	12	0.1017	5.040	1.482	22.954	0.275	4.008	1.105	3.935	0.431	-0.610	5.111	6.772	4.005	0.977	92.082	3.539	101.970	8.552
<b>12.00" Depth</b>																				
1200SSTT200-54	12.113	16	0.0566	3.060	0.900	16.177	0.236	2.671	0.864	4.239	0.512	-0.739	0.961	6.547	4.334	0.971	38.248	0.969	42.614	1.091
1200SSTT200-68	12.143	14	0.0713	3.849	1.132	20.336	0.294	3.350	1.054	4.238	0.509	-0.736	1.918	8.164	4.332	0.971	56.706	1.914	63.060	2.737
1200SSTT200-97	12.203	12	0.1017	5.472	1.609	28.881	0.410	4.733	1.409	4.236	0.505	-0.729	5.549	11.391	4.328	0.972	102.860	3.858	113.920	8.004
<b>14.00" Depth</b>																				
1400SSTT200-68	14.143	14	0.0713	4.334	1.275	29.986	0.301	4.241	1.197	4.850	0.486	-0.670	2.160	11.622	4.920	0.981	66.361	2.244	73.476	2.340
1400SSTT200-97	14.203	12	0.1017	6.164	1.813	42.587	0.421	5.997	1.593	4.847	0.482	-0.664	6.250	16.219	4.916	0.982	120.820	4.539	133.230	6.835

## Notations

I <sub>x</sub>	Full Moment of Inertia about the X axis
I <sub>y</sub>	Full Moment of Inertia about the Y axis
S <sub>x</sub>	Full Section Modulus about the X axis
S <sub>y</sub>	Full Section Modulus about the Y axis
R <sub>x</sub> , R <sub>y</sub>	Radius of Gyration about the X and Y axis, respectively
X <sub>o</sub>	Distance between Centroid and Shear Center
J	St. Venant's Torsion Constant
C <sub>w</sub>	Torsional Warping Constant
R <sub>o</sub>	Polar Radius of Gyration about the Shear Center
β	Torsional-Flexural Constant
I <sub>xn</sub>	Moment of Inertia at Slit about the X axis
A <sub>n</sub>	Cross-sectional Area at Punch-Out
M <sub>at</sub>	Fully-braced Allowable Moment at Emboss Slit
V <sub>at</sub>	Allowable Shear at Slit
M <sub>af</sub>	Fully-braced Allowable Moment at Full Section
V <sub>af</sub>	Allowable Shear at Full Section

## Notes

- The yield strength, F<sub>y</sub>, is 33 ksi for 18 gauge and 50 ksi for 16, 14, and 12 gauge steel.
- Tabulated weight values based on 4'-0" o.c. punch-out progression.



Joist Designation	10 psf Dead Load and 40 psf Live Load							
	TL Deflection = L/240, LL Deflection = L/360 Single Span • Spacing (in) o.c.				TL Deflection = L/240, LL Deflection = L/480 Single Span • Spacing (in) o.c.			
	12	16	19.2	24	12	16	19.2	24
725SSCJ175-43	15' 3"	13' 2"	12' 1"	10' 9"	14' 10"	13' 2"	12' 1"	10' 9"
725SSCJ175-54	17' 7"	15' 11"	15' 0"	13' 11"	15' 11"	14' 6"	13' 8"	12' 8"
725SSCJ175-68	18' 10"	17' 1"	16' 1"	14' 11"	17' 1"	15' 7"	14' 8"	13' 7"
800SSCJ175-43	17' 1"	14' 10"	13' 6"	12' 1"	16' 1"	14' 7"	13' 6"	12' 1"
800SSCJ175-54	19' 0"	17' 3"	16' 3"	15' 1"	17' 3"	15' 8"	14' 9"	13' 8"
800SSCJ175-68	20' 5"	18' 6"	17' 5"	16' 2"	18' 6"	16' 10"	15' 10"	14' 9"
925SSCJ175-54	21' 5"	19' 5"	18' 3"	17' 0"	19' 5"	17' 8"	16' 7"	15' 5"
925SSCJ175-68	23' 0"	20' 10"	19' 8"	18' 3"	20' 10"	19' 0"	17' 10"	16' 7"
925SSCJ175-97	25' 7"	23' 3"	21' 10"	20' 4"	23' 3"	21' 1"	19' 10"	18' 5"
1000SSCJ200-54	23' 3"	21' 2"	19' 11"	18' 6"	21' 2"	19' 3"	18' 1"	16' 9"
1000SSCJ200-68	25' 0"	22' 9"	21' 5"	19' 10"	22' 9"	20' 8"	19' 5"	18' 0"
1000SSCJ200-97	27' 10"	25' 4"	23' 10"	22' 1"	25' 4"	23' 0"	21' 8"	20' 1"
1125SSCJ175-54	25' 1"	22' 10"	21' 6"	19' 11"	22' 10"	20' 9"	19' 6"	18' 1"
1125SSCJ175-68	27' 0"	24' 6"	23' 1"	21' 5"	24' 6"	22' 3"	21' 0"	19' 6"
1125SSCJ175-97	30' 1"	27' 4"	25' 9"	23' 11"	27' 4"	24' 10"	23' 4"	21' 8"
1200SSCJ200-54	27' 0"	23' 11"	21' 10"	19' 7"	24' 7"	22' 4"	21' 0"	19' 6"
1200SSCJ200-68	29' 1"	26' 5"	24' 10"	23' 1"	26' 5"	24' 0"	22' 7"	20' 11"
1200SSCJ200-97	32' 5"	29' 5"	27' 8"	25' 9"	29' 5"	26' 9"	25' 2"	23' 4"
1400SSCJ200-68	33' 0"	30' 0"	28' 3"	26' 3"	30' 0"	27' 3"	25' 8"	23' 10"
1400SSCJ200-97	36' 10"	33' 6"	31' 6"	29' 3"	33' 6"	30' 5"	28' 8"	26' 7"

The technical information contained in these 'Tables' was prepared to assist professional engineers and architects in the selection of the Sure-Span® Floor Joist System and should only be used with the guidance and judgment of such architect or engineer.

**Span Table Notes**

- Spans are based on continuous lateral support of compression flange.
- Clip angle must be attached to the hard side of joist.
- Spans are not valid if any portion of the Sure-Span® flared hole falls over a bearing support.
- Minimum F<sub>y</sub> is 33 ksi for 18 gauge, 50 ksi for 16, 14, and 12 gauge steel.
- The minimum bearing joist length is 1.625'. Please consult CEMCO Design Engineer for use of smaller bearing joist length.
- Recommended bridging/blocking is 8' - 0" on-center maximum.
- Rim Track is to have continuous bearing support along the length (i.e. top of wall installation). Please consult CEMCO Design Engineer for all other support conditions.
- If an additional concentrated load is located at the end bearings of joist, web crippling must be checked separately.

- Leading edge of first hole shall be typically 10" minimum from edge of bearing support.
- TL = Total Load; LL = Live Load
- Applications involving multiple spans, cantilevers, concentrated loads, impact loading, and etc., should be investigated separately.
- Deflection and stress calculations did not consider composite action of sheathing materials.
- Values in 'Tables' are subject to change contingent upon authorized national/international evaluating agency's approval.

The data contained in this CEMCO publication is intended to be informative and only as a design aid. It should be used as a technical guideline only and does not replace the judgment and design intent of a qualified Architect and/or Engineer.

Because physical properties vary from competitive products, information from this Publication should be used only with CEMCO joist and track sections. CEMCO assumes no liability for failure resulting from the use of its drawings, computations, or for failure resulting from the use of alternative materials, or improper application or installation.

Joist Designation	15 psf Dead Load and 125 psf Live Load							
	TL Deflection = L/240, LL Deflection = L/360 Single Span • Spacing (in) o.c.				TL Deflection = L/240, LL Deflection = L/480 Single Span • Spacing (in) o.c.			
	12	16	19.2	24	12	16	19.2	24
725SSCJ175-43	9' 1"	7' 11"	7' 2"	6' 5"	9' 1"	7' 11"	7' 2"	6' 5"
725SSCJ175-54	12' 0"	10' 10"	9' 11"	8' 10"	10' 11"	9' 11"	9' 4"	8' 8"
725SSCJ175-68	12' 11"	11' 9"	11' 0"	10' 3"	11' 9"	10' 8"	10' 0"	9' 4"
800SSCJ175-43	10' 3"	8' 10"	8' 1"	7' 3"	10' 3"	8' 10"	8' 1"	7' 3"
800SSCJ175-54	13' 0"	11' 10"	11' 1"	10' 0"	11' 10"	10' 9"	10' 1"	9' 4"
800SSCJ175-68	13' 11"	12' 8"	11' 11"	11' 1"	12' 8"	11' 6"	10' 10"	10' 1"
925SSCJ175-54	14' 8"	13' 3"	12' 2"	10' 10"	13' 3"	12' 1"	11' 4"	10' 7"
925SSCJ175-68	15' 9"	14' 3"	13' 5"	12' 5"	14' 3"	13' 0"	12' 2"	11' 4"
925SSCJ175-97	17' 6"	15' 11"	14' 11"	13' 11"	15' 11"	14' 5"	13' 7"	12' 7"
1000SSCJ200-54	15' 11"	14' 2"	12' 11"	11' 7"	14' 6"	13' 2"	12' 4"	11' 6"
1000SSCJ200-68	17' 1"	15' 7"	14' 8"	13' 6"	15' 7"	14' 1"	13' 3"	12' 4"
1000SSCJ200-97	19' 1"	17' 4"	16' 4"	15' 2"	17' 4"	15' 9"	14' 10"	13' 9"
1125SSCJ175-54	17' 1"	14' 10"	13' 6"	12' 1"	15' 7"	14' 2"	13' 4"	12' 1"
1125SSCJ175-68	18' 6"	16' 9"	15' 7"	13' 11"	16' 9"	15' 3"	14' 4"	13' 4"
1125SSCJ175-97	20' 7"	18' 8"	17' 7"	16' 4"	18' 8"	17' 0"	16' 0"	14' 10"
1200SSCJ200-54	16' 6"	14' 4"	13' 1"	11' 8"	16' 6"	14' 4"	13' 1"	11' 8"
1200SSCJ200-68	19' 10"	18' 1"	16' 8"	14' 11"	18' 1"	16' 5"	15' 5"	14' 4"
1200SSCJ200-97	22' 2"	20' 2"	18' 11"	17' 7"	20' 2"	18' 4"	17' 3"	16' 0"
1400SSCJ200-68	22' 7"	19' 11"	18' 2"	16' 3"	20' 6"	18' 8"	17' 7"	16' 3"
1400SSCJ200-97	25' 3"	22' 11"	21' 7"	20' 0"	22' 11"	20' 10"	19' 7"	18' 2"

The technical information contained in these 'Tables' was prepared to assist professional engineers and architects in the selection of the Sure-Span® Floor Joist System and should only be used with the guidance and judgment of such architect or engineer.

### Span Table Notes

- Spans are based on continuous lateral support of compression flange.
- Clip angle must be attached to the hard side of joist.
- Spans are not valid if any portion of the Sure-Span® flared hole falls over a bearing support.
- Minimum  $F_y$  is 33 ksi for 18 gauge, 50 ksi for 16, 14, and 12 gauge steel.
- The minimum bearing joist length is 1.625'. Please consult CEMCO Design Engineer for use of smaller bearing joist length.
- Recommended bridging/blocking is 8' - 0" on-center maximum.
- Rim Track is to have continuous bearing support along the length (i.e. top of wall installation). Please consult CEMCO Design Engineer for all other support conditions.
- If an additional concentrated load is located at the end bearings of joist, web crippling must be checked separately.
- Leading edge of first hole shall be typically 10" minimum from edge of bearing support.
- TL = Total Load; LL = Live Load
- Applications involving multiple spans, cantilevers, concentrated loads, impact loading, and etc., should be investigated separately.
- Deflection and stress calculations did not consider composite action of sheathing materials.
- Values in 'Tables' are subject to change contingent upon authorized national/international evaluating agency's approval.

The data contained in this CEMCO publication is intended to be informative and only as a design aid. It should be used as a technical guideline only and does not replace the judgment and design intent of a qualified Architect and/or Engineer.

Because physical properties vary from competitive products, information from this Publication should be used only with CEMCO joist and track sections. CEMCO assumes no liability for failure resulting from the use of its drawings, computations, or for failure resulting from the use of alternative materials, or improper application or installation.



Joist Designation	15 psf Dead Load and 40 psf Live Load							
	TL Deflection = L/240, LL Deflection = L/360 Single Span • Spacing (in) o.c.				TL Deflection = L/240, LL Deflection = L/480 Single Span • Spacing (in) o.c.			
	12	16	19.2	24	12	16	19.2	24
725SSCJ175-43	14' 6"	12' 7"	11' 6"	10' 3"	14' 6"	12' 7"	11' 6"	10' 3"
725SSCJ175-54	17' 7"	15' 11"	15' 0"	13' 11"	15' 11"	14' 6"	13' 8"	12' 8"
725SSCJ175-68	18' 10"	17' 1"	16' 1"	14' 11"	17' 1"	15' 7"	14' 8"	13' 7"
800SSCJ175-43	16' 4"	14' 2"	12' 11"	11' 6"	16' 1"	14' 2"	12' 11"	11' 6"
800SSCJ175-54	19' 0"	17' 3"	16' 3"	15' 1"	17' 3"	15' 8"	14' 9"	13' 8"
800SSCJ175-68	20' 5"	18' 6"	17' 5"	16' 2"	18' 6"	16' 10"	15' 10"	14' 9"
925SSCJ175-54	21' 5"	19' 5"	18' 3"	17' 0"	19' 5"	17' 8"	16' 7"	15' 5"
925SSCJ175-68	23' 0"	20' 10"	19' 8"	18' 3"	20' 10"	19' 0"	17' 10"	16' 7"
925SSCJ175-97	25' 7"	23' 3"	21' 10"	20' 4"	23' 3"	21' 1"	19' 10"	18' 5"
1000SSCJ200-54	23' 3"	21' 2"	19' 11"	18' 6"	21' 2"	19' 3"	18' 1"	16' 9"
1000SSCJ200-68	25' 0"	22' 9"	21' 5"	19' 10"	22' 9"	20' 8"	19' 5"	18' 0"
1000SSCJ200-97	27' 10"	25' 4"	23' 10"	22' 1"	25' 4"	23' 0"	21' 8"	20' 1"
1125SSCJ175-54	25' 1"	22' 10"	21' 6"	19' 3"	22' 10"	20' 9"	19' 6"	18' 1"
1125SSCJ175-68	27' 0"	24' 6"	23' 1"	21' 5"	24' 6"	22' 3"	21' 0"	19' 6"
1125SSCJ175-97	30' 1"	27' 4"	25' 9"	23' 11"	27' 4"	24' 10"	23' 4"	21' 8"
1200SSCJ200-54	26' 4"	22' 10"	20' 10"	18' 8"	24' 7"	22' 4"	20' 10"	18' 8"
1200SSCJ200-68	29' 1"	26' 5"	24' 10"	23' 1"	26' 5"	24' 0"	22' 7"	20' 11"
1200SSCJ200-97	32' 5"	29' 5"	27' 8"	25' 9"	29' 5"	26' 9"	25' 2"	23' 4"
1400SSCJ200-68	33' 0"	30' 0"	28' 3"	25' 11"	30' 0"	27' 3"	25' 8"	23' 10"
1400SSCJ200-97	36' 10"	33' 6"	31' 6"	29' 3"	33' 6"	30' 5"	28' 8"	26' 7"

The technical information contained in these 'Tables' was prepared to assist professional engineers and architects in the selection of the Sure-Span® Floor Joist System and should only be used with the guidance and judgment of such architect or engineer.

**Span Table Notes**

1. Spans are based on continuous lateral support of compression flange.
2. Clip angle must be attached to the hard side of joist.
3. Spans are not valid if any portion of the Sure-Span® flared hole falls over a bearing support.
4. F<sub>y</sub> is 33 ksi for 18 gauge, 50 ksi for 16, 14, and 12 gauge steel.
5. The minimum bearing stud flange width is 1.625". Please consult CEMCO Design Engineer for use of smaller bearing stud flanges width.
6. Recommended bridging/blocking is 8'-0" on center, maximum.
7. Rim Track is to have continuous bearing support along the length (i.e. top of wall installation). Please consult CEMCO Design Engineer for all other support conditions.
8. If an additional concentrated load is located at the end bearing of joist, web crippling must be checked separately.

9. Leading edge of first hole shall be typically 10" minimum from inside face of bearing support.
10. TL = Total Load; LL = Live Load
11. Applications involving multiple spans, cantilevers, concentrated loads, impact loading, and etc., should be investigated separately.
12. Deflection and stress calculations did not consider composite action of sheathing materials.
13. Values in 'Tables' are subject to change contingent upon ICC ES approval.

The data contained in this CEMCO publication is intended to be informative and accurate. It should be used as a Technical Guideline only and does not replace the Judgment and Design of a qualified Architect and/or Engineer.

Because physical properties vary from competitive products, information from this Publication should be used only with CEMCO Stud and Track Sections. CEMCO assumes no liability for failure resulting from the use of its drawings, computations or for failure resulting from the use of alternative materials, or improper application or installation.

Joist Designation	20 psf Dead Load and 125 psf Live Load							
	TL Deflection = L/240, LL Deflection = L/360 Single Span • Spacing (in) o.c.				TL Deflection = L/240, LL Deflection = L/480 Single Span • Spacing (in) o.c.			
	12	16	19.2	24	12	16	19.2	24
725SSCJ175-43	8' 11"	7' 9"	7' 1"	6' 4"	8' 11"	7' 9"	7' 1"	6' 4"
725SSCJ175-54	12' 0"	10' 8"	9' 8"	8' 8"	10' 11"	9' 11"	9' 4"	8' 8"
725SSCJ175-68	12' 11"	11' 9"	11' 0"	10' 3"	11' 9"	10' 8"	10' 0"	9' 4"
800SSCJ175-43	10' 1"	8' 8"	7' 11"	7' 1"	10' 1"	8' 8"	7' 11"	7' 1"
800SSCJ175-54	13' 0"	11' 10"	11' 0"	9' 10"	11' 10"	10' 9"	10' 1"	9' 4"
800SSCJ175-68	13' 11"	12' 8"	11' 11"	11' 1"	12' 8"	11' 6"	10' 10"	10' 1"
925SSCJ175-54	14' 8"	13' 1"	11' 11"	10' 8"	13' 3"	12' 1"	11' 4"	10' 7"
925SSCJ175-68	15' 9"	14' 3"	13' 5"	12' 3"	14' 3"	13' 0"	12' 2"	11' 4"
925SSCJ175-97	17' 6"	15' 11"	14' 11"	13' 11"	15' 11"	14' 5"	13' 7"	12' 7"
1000SSCJ200-54	15' 11"	13' 11"	12' 9"	11' 5"	14' 6"	13' 2"	12' 4"	11' 5"
1000SSCJ200-68	17' 1"	15' 7"	14' 8"	13' 3"	15' 7"	14' 1"	13' 3"	12' 4"
1000SSCJ200-97	19' 1"	17' 4"	16' 4"	15' 2"	17' 4"	15' 9"	14' 10"	13' 9"
1125SSCJ175-54	16' 9"	14' 6"	13' 3"	11' 10"	15' 7"	14' 2"	13' 3"	11' 10"
1125SSCJ175-68	18' 6"	16' 9"	15' 3"	13' 8"	16' 9"	15' 3"	14' 4"	13' 4"
1125SSCJ175-97	20' 7"	18' 8"	17' 7"	16' 4"	18' 8"	17' 0"	16' 0"	14' 10"
1200SSCJ200-54	16' 3"	14' 1"	12' 10"	11' 6"	16' 3"	14' 1"	12' 10"	11' 6"
1200SSCJ200-68	19' 10"	18' 0"	16' 5"	14' 8"	18' 1"	16' 5"	15' 5"	14' 4"
1200SSCJ200-97	22' 2"	20' 2"	18' 11"	17' 7"	20' 2"	18' 4"	17' 3"	16' 0"
1400SSCJ200-68	22' 7"	19' 7"	17' 10"	16' 0"	20' 6"	18' 8"	17' 7"	16' 0"
1400SSCJ200-97	25' 3"	22' 11"	21' 7"	19' 10"	22' 11"	20' 10"	19' 7"	18' 2"

The technical information contained in these 'Tables' was prepared to assist professional engineers and architects in the selection of the Sure-Span® Floor Joist System and should only be used with the guidance and judgment of such architect or engineer.

### Span Table Notes

- Spans are based on continuous lateral support of compression flange.
- Clip angle must be attached to the hard side of joist.
- Spans are not valid if any portion of the Sure-Span® flared hole falls over a bearing support.
- $F_y$  is 33 ksi for 18 gauge, 50 ksi for 16, 14, and 12 gauge steel.
- The minimum bearing stud flange width is 1.625". Please consult CEMCO Design Engineer for use of smaller bearing stud flanges width.
- Recommended bridging/blocking is 8'-0" on center, maximum.
- Rim Track is to have continuous bearing support along the length (i.e. top of wall installation). Please consult CEMCO Design Engineer for all other support conditions.
- If an additional concentrated load is located at the end bearing of joist, web crippling must be checked separately.
- Leading edge of first hole shall be typically 10" minimum from inside face of bearing support.
- TL = Total Load; LL = Live Load
- Applications involving multiple spans, cantilevers, concentrated loads, impact loading, and etc., should be investigated separately.
- Deflection and stress calculations did not consider composite action of sheathing materials.
- Values in 'Tables' are subject to change contingent upon ICC ES approval.

The data contained in this CEMCO publication is intended to be informative and accurate. It should be used as a Technical Guideline only and does not replace the Judgment and Design of a qualified Architect and/or Engineer.

Because physical properties vary from competitive products, information from this Publication should be used only with CEMCO Stud and Track Sections. CEMCO assumes no liability for failure resulting from the use of its drawings, computations or for failure resulting from the use of alternative materials, or improper application or installation.



Joist Designation	20 psf Dead Load and 40 psf Live Load							
	TL Deflection = L/240, LL Deflection = L/360 Single Span • Spacing (in) o.c.				TL Deflection = L/240, LL Deflection = L/480 Single Span • Spacing (in) o.c.			
	12	16	19.2	24	12	16	19.2	24
725SSCJ175-43	13' 11"	12' 1"	11' 0"	9' 10"	13' 11"	12' 1"	11' 0"	9' 10"
725SSCJ175-54	17' 7"	15' 11"	15' 0"	13' 6"	15' 11"	14' 6"	13' 8"	12' 8"
725SSCJ175-68	18' 10"	17' 1"	16' 1"	14' 11"	17' 1"	15' 7"	14' 8"	13' 7"
800SSCJ175-43	15' 8"	13' 6"	12' 4"	11' 1"	15' 8"	13' 6"	12' 4"	11' 1"
800SSCJ175-54	19' 0"	17' 3"	16' 3"	15' 1"	17' 3"	15' 8"	14' 9"	13' 8"
800SSCJ175-68	20' 5"	18' 6"	17' 5"	16' 2"	18' 6"	16' 10"	15' 10"	14' 9"
925SSCJ175-54	21' 5"	19' 5"	18' 3"	16' 7"	19' 5"	17' 8"	16' 7"	15' 5"
925SSCJ175-68	23' 0"	20' 10"	19' 8"	18' 3"	20' 10"	19' 0"	17' 10"	16' 7"
925SSCJ175-97	25' 7"	23' 3"	21' 10"	20' 4"	23' 3"	21' 1"	19' 10"	18' 5"
1000SSCJ200-54	23' 3"	21' 2"	19' 9"	17' 8"	21' 2"	19' 3"	18' 1"	16' 9"
1000SSCJ200-68	25' 0"	22' 9"	21' 5"	19' 10"	22' 9"	20' 8"	19' 5"	18' 0"
1000SSCJ200-97	27' 10"	25' 4"	23' 10"	22' 1"	25' 4"	23' 0"	21' 8"	20' 1"
1125SSCJ175-54	25' 1"	22' 7"	20' 8"	18' 5"	22' 10"	20' 9"	19' 6"	18' 1"
1125SSCJ175-68	27' 0"	24' 6"	23' 1"	21' 3"	24' 6"	22' 3"	21' 0"	19' 6"
1125SSCJ175-97	30' 1"	27' 4"	25' 9"	23' 11"	27' 4"	24' 10"	23' 4"	21' 8"
1200SSCJ200-54	25' 3"	21' 10"	19' 11"	17' 10"	24' 7"	21' 10"	19' 11"	17' 10"
1200SSCJ200-68	29' 1"	26' 5"	24' 10"	22' 10"	26' 5"	24' 0"	22' 7"	20' 11"
1200SSCJ200-97	32' 5"	29' 5"	27' 8"	25' 9"	29' 5"	26' 9"	25' 2"	23' 4"
1400SSCJ200-68	33' 0"	30' 0"	27' 9"	24' 10"	30' 0"	27' 3"	25' 8"	23' 10"
1400SSCJ200-97	36' 10"	33' 6"	31' 6"	29' 3"	33' 6"	30' 5"	28' 8"	26' 7"

The technical information contained in these 'Tables' was prepared to assist professional engineers and architects in the selection of the Sure-Span® Floor Joist System and should only be used with the guidance and judgment of such architect or engineer.

### Span Table Notes

- Spans are based on continuous lateral support of compression flange.
- Clip angle must be attached to the hard side of joist.
- Spans are not valid if any portion of the Sure-Span® flared hole falls over a bearing support.
- F<sub>y</sub> is 33 ksi for 18 gauge, 50 ksi for 16, 14, and 12 gauge steel.
- The minimum bearing stud flange width is 1.625". Please consult CEMCO Design Engineer for use of smaller bearing stud flanges width.
- Recommended bridging/blocking is 8'-0" on center, maximum.
- Rim Track is to have continuous bearing support along the length (i.e. top of wall installation). Please consult CEMCO Design Engineer for all other support conditions.
- If an additional concentrated load is located at the end bearing of joist, web crippling must be checked separately.

- Leading edge of first hole shall be typically 10" minimum from inside face of bearing support.
- TL = Total Load; LL = Live Load
- Applications involving multiple spans, cantilevers, concentrated loads, impact loading, and etc., should be investigated separately.
- Deflection and stress calculations did not consider composite action of sheathing materials.
- Values in 'Tables' are subject to change contingent upon ICC ES approval.

The data contained in this CEMCO publication is intended to be informative and accurate. It should be used as a Technical Guideline only and does not replace the Judgment and Design of a qualified Architect and/or Engineer.

Because physical properties vary from competitive products, information from this Publication should be used only with CEMCO Stud and Track Sections. CEMCO assumes no liability for failure resulting from the use of its drawings, computations or for failure resulting from the use of alternative materials, or improper application or installation.

Joist Designation	25 psf Dead Load and 125 psf Live Load							
	TL Deflection = L/240, LL Deflection = L/360 Single Span • Spacing (in) o.c.				TL Deflection = L/240, LL Deflection = L/480 Single Span • Spacing (in) o.c.			
	12	16	19.2	24	12	16	19.2	24
725SSCJ175-43	8' 10"	7' 7"	6' 11"	6' 3"	8' 10"	7' 7"	6' 11"	6' 3"
725SSCJ175-54	12' 0"	10' 5"	9' 6"	8' 6"	10' 11"	9' 11"	9' 4"	8' 6"
725SSCJ175-68	12' 11"	11' 9"	11' 0"	10' 3"	11' 9"	10' 8"	10' 0"	9' 4"
800SSCJ175-43	9' 11"	8' 7"	7' 10"	7' 0"	9' 11"	8' 7"	7' 10"	7' 0"
800SSCJ175-54	13' 0"	11' 10"	10' 10"	9' 8"	11' 10"	10' 9"	10' 1"	9' 4"
800SSCJ175-68	13' 11"	12' 8"	11' 11"	11' 1"	12' 8"	11' 6"	10' 10"	10' 1"
925SSCJ175-54	14' 8"	12' 10"	11' 9"	10' 6"	13' 3"	12' 1"	11' 4"	10' 6"
925SSCJ175-68	15' 9"	14' 3"	13' 5"	12' 0"	14' 3"	13' 0"	12' 2"	11' 4"
925SSCJ175-97	17' 6"	15' 11"	14' 11"	13' 11"	15' 11"	14' 5"	13' 7"	12' 7"
1000SSCJ200-54	15' 10"	13' 9"	12' 6"	11' 2"	14' 6"	13' 2"	12' 4"	11' 2"
1000SSCJ200-68	17' 1"	15' 7"	14' 7"	13' 0"	15' 7"	14' 1"	13' 3"	12' 4"
1000SSCJ200-97	19' 1"	17' 4"	16' 4"	15' 2"	17' 4"	15' 9"	14' 10"	13' 9"
1125SSCJ175-54	16' 6"	14' 4"	13' 1"	11' 8"	15' 7"	14' 2"	13' 1"	11' 8"
1125SSCJ175-68	18' 6"	16' 6"	15' 0"	13' 5"	16' 9"	15' 3"	14' 4"	13' 4"
1125SSCJ175-97	20' 7"	18' 8"	17' 7"	16' 4"	18' 8"	17' 0"	16' 0"	14' 10"
1200SSCJ200-54	15' 11"	13' 10"	12' 7"	11' 3"	15' 11"	13' 10"	12' 7"	11' 3"
1200SSCJ200-68	19' 10"	17' 8"	16' 2"	14' 5"	18' 1"	16' 5"	15' 5"	14' 4"
1200SSCJ200-97	22' 2"	20' 2"	18' 11"	17' 7"	20' 2"	18' 4"	17' 3"	16' 0"
1400SSCJ200-68	22' 2"	19' 3"	17' 7"	15' 8"	20' 6"	18' 8"	17' 7"	15' 8"
1400SSCJ200-97	25' 3"	22' 11"	21' 7"	19' 6"	22' 11"	20' 10"	19' 7"	18' 2"

The technical information contained in these 'Tables' was prepared to assist professional engineers and architects in the selection of the Sure-Span® Floor Joist System and should only be used with the guidance and judgment of such architect or engineer.

### Span Table Notes

- Spans are based on continuous lateral support of compression flange.
- Clip angle must be attached to the hard side of joist.
- Spans are not valid if any portion of the Sure-Span® flared hole falls over a bearing support.
- $F_y$  is 33 ksi for 18 gauge, 50 ksi for 16, 14, and 12 gauge steel.
- The minimum bearing stud flange width is 1.625". Please consult CEMCO Design Engineer for use of smaller bearing stud flanges width.
- Recommended bridging/blocking is 8'-0" on center, maximum.
- Rim Track is to have continuous bearing support along the length (i.e. top of wall installation). Please consult CEMCO Design Engineer for all other support conditions.
- If an additional concentrated load is located at the end bearing of joist, web crippling must be checked separately.
- Leading edge of first hole shall be typically 10" minimum from inside face of bearing support.
- TL = Total Load; LL = Live Load
- Applications involving multiple spans, cantilevers, concentrated loads, impact loading, and etc., should be investigated separately.
- Deflection and stress calculations did not consider composite action of sheathing materials.
- Values in 'Tables' are subject to change contingent upon ICC ES approval.

The data contained in this CEMCO publication is intended to be informative and accurate. It should be used as a Technical Guideline only and does not replace the Judgment and Design of a qualified Architect and/or Engineer.

Because physical properties vary from competitive products, information from this Publication should be used only with CEMCO Stud and Track Sections. CEMCO assumes no liability for failure resulting from the use of its drawings, computations or for failure resulting from the use of alternative materials, or improper application or installation.



Joist Designation	25 psf Dead Load and 40 psf Live Load							
	TL Deflection = L/240, LL Deflection = L/360 Single Span • Spacing (in) o.c.				TL Deflection = L/240, LL Deflection = L/480 Single Span • Spacing (in) o.c.			
	12	16	19.2	24	12	16	19.2	24
725SSCJ175-43	13' 4"	11' 7"	10' 7"	9' 5"	13' 4"	11' 7"	10' 7"	9' 5"
725SSCJ175-54	17' 1"	15' 6"	14' 6"	13' 0"	15' 11"	14' 6"	13' 8"	12' 8"
725SSCJ175-68	18' 4"	16' 8"	15' 8"	14' 7"	17' 1"	15' 7"	14' 8"	13' 7"
800SSCJ175-43	15' 0"	13' 0"	11' 10"	10' 7"	15' 0"	13' 0"	11' 10"	10' 7"
800SSCJ175-54	18' 6"	16' 10"	15' 10"	14' 8"	17' 3"	15' 8"	14' 9"	13' 8"
800SSCJ175-68	19' 10"	18' 1"	17' 0"	15' 9"	18' 6"	16' 10"	15' 10"	14' 9"
925SSCJ175-54	20' 10"	18' 11"	17' 10"	15' 11"	19' 5"	17' 8"	16' 7"	15' 5"
925SSCJ175-68	22' 4"	20' 4"	19' 1"	17' 9"	20' 10"	19' 0"	17' 10"	16' 7"
925SSCJ175-97	24' 11"	22' 7"	21' 3"	19' 9"	23' 3"	21' 1"	19' 10"	18' 5"
1000SSCJ200-54	22' 8"	20' 7"	19' 0"	17' 0"	21' 2"	19' 3"	18' 1"	16' 9"
1000SSCJ200-68	24' 4"	22' 2"	20' 10"	19' 4"	22' 9"	20' 8"	19' 5"	18' 0"
1000SSCJ200-97	27' 2"	24' 8"	23' 2"	21' 6"	25' 4"	23' 0"	21' 8"	20' 1"
1125SSCJ175-54	24' 6"	21' 9"	19' 10"	17' 9"	22' 10"	20' 9"	19' 6"	17' 9"
1125SSCJ175-68	26' 4"	23' 11"	22' 6"	20' 5"	24' 6"	22' 3"	21' 0"	19' 6"
1125SSCJ175-97	29' 4"	26' 7"	25' 1"	23' 3"	27' 4"	24' 10"	23' 4"	21' 8"
1200SSCJ200-54	24' 3"	21' 0"	19' 2"	17' 2"	24' 3"	21' 0"	19' 2"	17' 2"
1200SSCJ200-68	28' 4"	25' 8"	24' 2"	21' 11"	26' 5"	24' 0"	22' 7"	20' 11"
1200SSCJ200-97	31' 7"	28' 8"	27' 0"	25' 0"	29' 5"	26' 9"	25' 2"	23' 4"
1400SSCJ200-68	32' 2"	29' 2"	26' 8"	23' 10"	30' 0"	27' 3"	25' 8"	23' 10"
1400SSCJ200-97	35' 11"	32' 7"	30' 8"	28' 6"	33' 6"	30' 5"	28' 8"	26' 7"

The technical information contained in these 'Tables' was prepared to assist professional engineers and architects in the selection of the Sure-Span® Floor Joist System and should only be used with the guidance and judgment of such architect or engineer.

### Span Table Notes

- Spans are based on continuous lateral support of compression flange.
- Clip angle must be attached to the hard side of joist.
- Spans are not valid if any portion of the Sure-Span® flared hole falls over a bearing support.
- F<sub>y</sub> is 33 ksi for 18 gauge, 50 ksi for 16, 14, and 12 gauge steel.
- The minimum bearing stud flange width is 1.625". Please consult CEMCO Design Engineer for use of smaller bearing stud flanges width.
- Recommended bridging/blocking is 8'-0" on center, maximum.
- Rim Track is to have continuous bearing support along the length (i.e. top of wall installation). Please consult CEMCO Design Engineer for all other support conditions.
- If an additional concentrated load is located at the end bearing of joist, web crippling must be checked separately.

- Leading edge of first hole shall be typically 10" minimum from inside face of bearing support.
- TL = Total Load; LL = Live Load
- Applications involving multiple spans, cantilevers, concentrated loads, impact loading, and etc., should be investigated separately.
- Deflection and stress calculations did not consider composite action of sheathing materials.
- Values in 'Tables' are subject to change contingent upon ICC ES approval.

The data contained in this CEMCO publication is intended to be informative and accurate. It should be used as a Technical Guideline only and does not replace the Judgment and Design of a qualified Architect and/or Engineer.

Because physical properties vary from competitive products, information from this Publication should be used only with CEMCO Stud and Track Sections. CEMCO assumes no liability for failure resulting from the use of its drawings, computations or for failure resulting from the use of alternative materials, or improper application or installation.

Joist Designation	40 psf Dead Load and 125 psf Live Load							
	TL Deflection = L/240, LL Deflection = L/360 Single Span • Spacing (in) o.c.				TL Deflection = L/240, LL Deflection = L/480 Single Span • Spacing (in) o.c.			
	12	16	19.2	24	12	16	19.2	24
725SSCJ175-43	8' 5"	7' 3"	6' 8"	5' 11"	8' 5"	7' 3"	6' 8"	5' 11"
725SSCJ175-54	11' 6"	10' 0"	9' 1"	8' 2"	10' 11"	9' 11"	9' 1"	8' 2"
725SSCJ175-68	12' 11"	11' 9"	11' 0"	9' 11"	11' 9"	10' 8"	10' 0"	9' 4"
800SSCJ175-43	9' 5"	8' 2"	7' 5"	6' 8"	9' 5"	8' 2"	7' 5"	6' 8"
800SSCJ175-54	13' 0"	11' 3"	10' 4"	9' 3"	11' 10"	10' 9"	10' 1"	9' 3"
800SSCJ175-68	13' 11"	12' 8"	11' 11"	11' 1"	12' 8"	11' 6"	10' 10"	10' 1"
925SSCJ175-54	14' 2"	12' 3"	11' 2"	9' 12"	13' 3"	12' 1"	11' 2"	10' 0"
925SSCJ175-68	15' 9"	14' 1"	12' 10"	11' 6"	14' 3"	13' 0"	12' 2"	11' 4"
925SSCJ175-97	17' 6"	15' 11"	14' 11"	13' 11"	15' 11"	14' 5"	13' 7"	12' 7"
1000SSCJ200-54	15' 1"	13' 1"	11' 11"	10' 8"	14' 6"	13' 1"	11' 11"	10' 8"
1000SSCJ200-68	17' 1"	15' 3"	13' 11"	12' 5"	15' 7"	14' 1"	13' 3"	12' 4"
1000SSCJ200-97	19' 1"	17' 4"	16' 4"	15' 2"	17' 4"	15' 9"	14' 10"	13' 9"
1125SSCJ175-54	15' 9"	13' 8"	12' 5"	11' 2"	15' 7"	13' 8"	12' 5"	11' 2"
1125SSCJ175-68	18' 2"	15' 8"	14' 4"	12' 10"	16' 9"	15' 3"	14' 4"	12' 10"
1125SSCJ175-97	20' 7"	18' 8"	17' 7"	15' 10"	18' 8"	17' 0"	16' 0"	14' 10"
1200SSCJ200-54	15' 3"	13' 2"	12' 0"	10' 9"	15' 3"	13' 2"	12' 0"	10' 9"
1200SSCJ200-68	19' 5"	16' 10"	15' 5"	13' 9"	18' 1"	16' 5"	15' 5"	13' 9"
1200SSCJ200-97	22' 2"	20' 2"	18' 11"	17' 0"	20' 2"	18' 4"	17' 3"	16' 0"
1400SSCJ200-68	21' 2"	18' 4"	16' 9"	15' 0"	20' 6"	18' 4"	16' 9"	15' 0"
1400SSCJ200-97	25' 3"	22' 9"	20' 10"	18' 7"	22' 11"	20' 10"	19' 7"	18' 2"

The technical information contained in these 'Tables' was prepared to assist professional engineers and architects in the selection of the Sure-Span® Floor Joist System and should only be used with the guidance and judgment of such architect or engineer.

### Span Table Notes

- Spans are based on continuous lateral support of compression flange.
- Clip angle must be attached to the hard side of joist.
- Spans are not valid if any portion of the Sure-Span® flared hole falls over a bearing support.
- $F_y$  is 33 ksi for 18 gauge, 50 ksi for 16, 14, and 12 gauge steel.
- The minimum bearing stud flange width is 1.625". Please consult CEMCO Design Engineer for use of smaller bearing stud flanges width.
- Recommended bridging/blocking is 8'-0" on center, maximum.
- Rim Track is to have continuous bearing support along the length (i.e. top of wall installation). Please consult CEMCO Design Engineer for all other support conditions.
- If an additional concentrated load is located at the end bearing of joist, web crippling must be checked separately.
- Leading edge of first hole shall be typically 10" minimum from inside face of bearing support.
- TL = Total Load; LL = Live Load
- Applications involving multiple spans, cantilevers, concentrated loads, impact loading, and etc., should be investigated separately.
- Deflection and stress calculations did not consider composite action of sheathing materials.
- Values in 'Tables' are subject to change contingent upon ICC ES approval.

The data contained in this CEMCO publication is intended to be informative and accurate. It should be used as a Technical Guideline only and does not replace the Judgment and Design of a qualified Architect and/or Engineer.

Because physical properties vary from competitive products, information from this Publication should be used only with CEMCO Stud and Track Sections. CEMCO assumes no liability for failure resulting from the use of its drawings, computations or for failure resulting from the use of alternative materials, or improper application or installation.



Joist Designation	40 psf Dead Load and 40 psf Live Load							
	TL Deflection = L/240, LL Deflection = L/360 Single Span • Spacing (in) o.c.				TL Deflection = L/240, LL Deflection = L/480 Single Span • Spacing (in) o.c.			
	12	16	19.2	24	12	16	19.2	24
725SSCJ175-43	12' 1"	10' 5"	9' 6"	8' 6"	12' 1"	10' 5"	9' 6"	8' 6"
725SSCJ175-54	15' 11"	14' 4"	13' 1"	11' 8"	15' 11"	14' 4"	13' 1"	11' 8"
725SSCJ175-68	17' 1"	15' 7"	14' 8"	13' 7"	17' 1"	15' 7"	14' 8"	13' 7"
800SSCJ175-43	13' 6"	11' 9"	10' 8"	9' 7"	13' 6"	11' 9"	10' 8"	9' 7"
800SSCJ175-54	17' 3"	15' 8"	14' 9"	13' 3"	17' 3"	15' 8"	14' 9"	13' 3"
800SSCJ175-68	18' 6"	16' 10"	15' 10"	14' 9"	18' 6"	16' 10"	15' 10"	14' 9"
925SSCJ175-54	19' 5"	17' 7"	16' 1"	14' 4"	19' 5"	17' 7"	16' 1"	14' 4"
925SSCJ175-68	20' 10"	19' 0"	17' 10"	16' 6"	20' 10"	19' 0"	17' 10"	16' 6"
925SSCJ175-97	23' 3"	21' 1"	19' 10"	18' 5"	23' 3"	21' 1"	19' 10"	18' 5"
1000SSCJ200-54	21' 2"	18' 9"	17' 2"	15' 4"	21' 2"	18' 9"	17' 2"	15' 4"
1000SSCJ200-68	22' 9"	20' 8"	19' 5"	17' 10"	22' 9"	20' 8"	19' 5"	17' 10"
1000SSCJ200-97	25' 4"	23' 0"	21' 8"	20' 1"	25' 4"	23' 0"	21' 8"	20' 1"
1125SSCJ175-54	22' 7"	19' 7"	17' 10"	16' 0"	22' 7"	19' 7"	17' 10"	16' 0"
1125SSCJ175-68	24' 6"	22' 3"	20' 7"	18' 5"	24' 6"	22' 3"	20' 7"	18' 5"
1125SSCJ175-97	27' 4"	24' 10"	23' 4"	21' 8"	27' 4"	24' 10"	23' 4"	21' 8"
1200SSCJ200-54	21' 10"	18' 11"	17' 3"	15' 5"	21' 10"	18' 11"	17' 3"	15' 5"
1200SSCJ200-68	26' 5"	24' 0"	22' 1"	19' 9"	26' 5"	24' 0"	22' 1"	19' 9"
1200SSCJ200-97	29' 5"	26' 9"	25' 2"	23' 4"	29' 5"	26' 9"	25' 2"	23' 4"
1400SSCJ200-68	30' 0"	26' 4"	24' 0"	21' 6"	30' 0"	26' 4"	24' 0"	21' 6"
1400SSCJ200-97	33' 6"	30' 5"	28' 8"	26' 7"	33' 6"	30' 5"	28' 8"	26' 7"

The technical information contained in these 'Tables' was prepared to assist professional engineers and architects in the selection of the Sure-Span® Floor Joist System and should only be used with the guidance and judgment of such architect or engineer.

**Span Table Notes**

- Spans are based on continuous lateral support of compression flange.
- Clip angle must be attached to the hard side of joist.
- Spans are not valid if any portion of the Sure-Span® flared hole falls over a bearing support.
- F<sub>y</sub> is 33 ksi for 18 gauge, 50 ksi for 16, 14, and 12 gauge steel.
- The minimum bearing stud flange width is 1.625". Please consult CEMCO Design Engineer for use of smaller bearing stud flanges width.
- Recommended bridging/blocking is 8'-0" on center, maximum.
- Rim Track is to have continuous bearing support along the length (i.e. top of wall installation). Please consult CEMCO Design Engineer for all other support conditions.
- If an additional concentrated load is located at the end bearing of joist, web crippling must be checked separately.

- Leading edge of first hole shall be typically 10" minimum from inside face of bearing support.
- TL = Total Load; LL = Live Load
- Applications involving multiple spans, cantilevers, concentrated loads, impact loading, and etc., should be investigated separately.
- Deflection and stress calculations did not consider composite action of sheathing materials.
- Values in 'Tables' are subject to change contingent upon ICC ES approval.

The data contained in this CEMCO publication is intended to be informative and accurate. It should be used as a Technical Guideline only and does not replace the Judgment and Design of a qualified Architect and/or Engineer.

Because physical properties vary from competitive products, information from this Publication should be used only with CEMCO Stud and Track Sections. CEMCO assumes no liability for failure resulting from the use of its drawings, computations or for failure resulting from the use of alternative materials, or improper application or installation.

Section Designation	End-One-Flange, EOF (lbs)			Interior-One-Flange, IOF (lbs)			End-Two-Flange, ETF (lbs)			Interior-Two-Flange, ITF (lbs)		
	Bearing Length (in)			Bearing Length (in)			Bearing Length (in)			Bearing Length (in)		
	2	4	6	2	4	6	2	4	6	2	4	6
<b>7.25" Depth</b>												
725SSCJ175-43	314	406	476	635	761	859	196	216	232	504	608	689
725SSCJ175-54	723	925	1081	1473	1750	1963	514	563	599	1193	1426	1605
725SSCJ175-68	1096	1392	1618	2253	2650	2955	867	942	1000	1800	2129	2382
<b>8.00" Depth</b>												
800SSCJ175-43	309	399	467	630	755	852	186	205	220	504	608	688
800SSCJ175-54	712	911	1064	1463	1738	1950	493	539	575	1192	1425	1605
800SSCJ175-68	1083	1374	1598	3421	2635	2938	837	909	965	1798	2128	2382
<b>9.25" Depth</b>												
925SSCJ175-54	695	890	1040	1449	1721	1930	459	503	536	1192	1424	1602
925SSCJ175-68	1061	1346	1566	2221	2612	2912	791	859	911	1797	2127	2380
925SSCJ175-97	2022	2533	2924	4291	4973	5495	1765	1899	2000	3399	3961	4393
<b>10.00" Depth</b>												
1000SSCJ200-54	686	878	1025	1441	1711	1919	440	481	514	1191	1424	1602
1000SSCJ200-68	1049	1330	1547	2209	2599	2897	764	831	881	1796	2126	2378
1000SSCJ200-97	2003	2508	2896	4273	4952	5472	1722	1852	1951	3399	3960	4391
<b>11.25" Depth</b>												
1125SSCJ175-54	671	859	1003	1426	1695	1902	409	448	478	1190	1423	1601
1125SSCJ175-68	1028	1306	1518	2191	2578	2873	723	786	833	1795	2124	2377
1125SSCJ175-97	1973	2471	2853	4245	4919	5435	1654	1778	1873	3395	3958	4388
<b>12.00" Depth</b>												
1200SSCJ200-54	662	848	989	1418	1686	1891	392	429	458	1189	1422	1600
1200SSCJ200-68	1017	1291	1501	2180	2565	2860	699	760	806	1794	2124	2376
1200SSCJ200-97	1957	2449	2828	4229	4900	5415	1615	1736	1829	3394	3956	4388
<b>14.00" Depth</b>												
1400SSCJ200-68	988	1255	1459	2154	2534	2826	638	694	737	1793	2122	2373
1400SSCJ200-97	1913	2395	2765	4187	4851	5362	1514	1629	1716	3392	3952	4384

## Notes

1. Allowable web crippling capacities are obtained by applying the factors of safety recommended on Table G5-2 of AISI S100-2016, for the various types of loading configurations
2. Calculated nominal web crippling capacities are checked against tested ultimate capacities to verify congruency.



# Expanding Your Solutions

## Corporate Headquarters

13191 Crossroads Parkway North, Suite 325, City of Industry, CA 91746

**P:** 800.775.2362 | **F:** 626.330.7598

## Southern California Manufacturing Facility

263 North Covina Lane, City of Industry, CA 91746

**P:** 800.775.2362 | **F:** 626.330.7598

## Northern California Manufacturing Facility

1001-A Pittsburg Antioch Hwy, Pittsburg, CA 94565

**P:** 925.473.9340 | **F:** 925.473.9341

## Commerce City Colorado Manufacturing Facility

9410 Heinz Way, Commerce City, CO 80640

**P:** 303.572.3626 | **F:** 303.572.3627

## Fort Worth Texas Manufacturing Facility

8600 Will Rogers Blvd, Fort Worth, TX 76140

**P:** 817.568.1525 | **F:** 817.568.2759

[www.cemcosteel.com](http://www.cemcosteel.com)

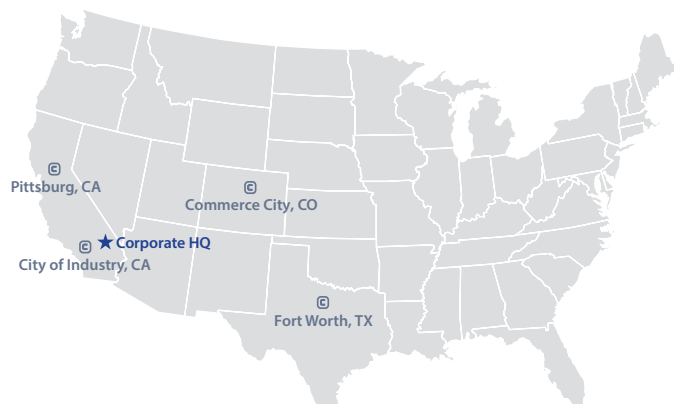

Effective 02/03/2026