

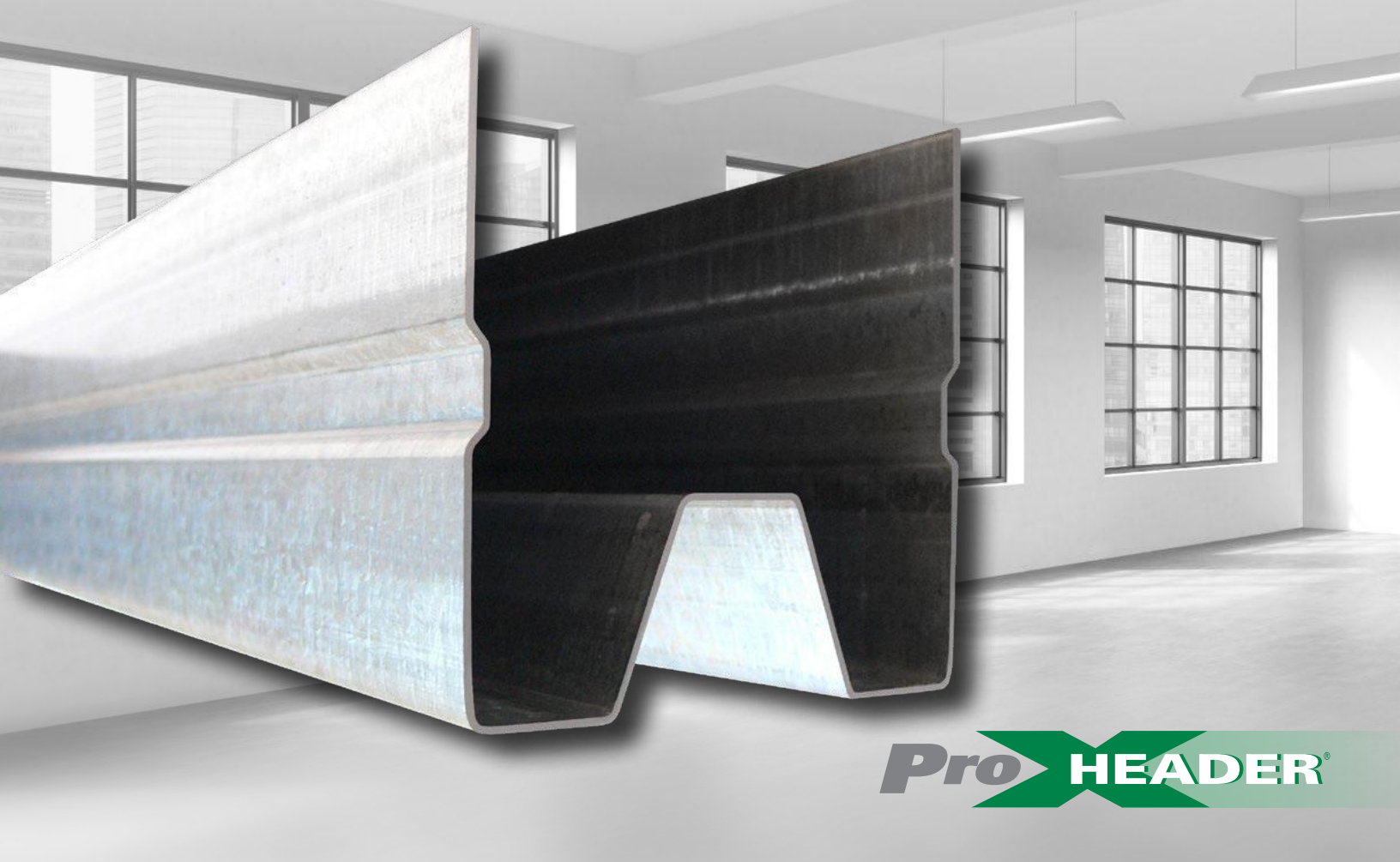

Expanding Your Solutions



Pro **HEADER**

ProX Header[®] Rough Opening System for Exterior & Interior

Table of Contents

Introduction to ProX Header® 3

ProX Header Installation 4

ProX Header Outer Sectional Properties; ProX Header Outer Allowable Values 5

ProX Header Clip Allowable Values: Without Insert, #8 Screw, #10 Screw 6

Table 9: Interior Header Schedule – IAPMO ER-0286 (IBC 2024, 2021 & CBC 2022) 7

Table 10: Interior Header Schedule – IAPMO ER-0286 (IBC 2024, 2021 & CBC 2022) 7

Table 11: Interior Header Schedule – IAPMO ER-0286 (IBC 2024, 2021 & CBC 2022) 8

Table 12: Interior Header Schedule – IAPMO ER-0286 (IBC 2024, 2021 & CBC 2022) 8

Table 13: Interior Header Schedule – IAPMO ER-0286 (IBC 2024, 2021 & CBC 2022) 9

Table 14: Interior Header Schedule – IAPMO ER-0286 (IBC 2024, 2021 & CBC 2022) 9



ProX Header® is a registered trademark of Brady Innovations, LLC.
 US Patent Nos. 6,799,408; 7,178,695; 7,730,695 & 8,281,544
 are owned by Brady Innovations, LLC

Disclaimer

All data, specifications, and details contained in this publication are intended as a general guide for using CEMCO cold-formed steel framing products and accessories. These products are not to be used in design or construction without an independent evaluation by a licensed and qualified engineer or architect to verify the suitability of a particular product for use in a specific application. CEMCO and its entities assume no liability for failure resulting from the use or misapplication of computations, detail drawings, and specifications contained herein. This publication contains the latest information available at the time of printing. CEMCO and its entities reserve the right to make changes or modifications to the materials of any of its products without out prior notice or obligation. Contact CEMCO at 800-775-2362 or www.cemcosteel.com for the latest information on these or any other CEMCO products.

Introduction

ProX Header®

The unique shape of ProX Header is engineered to carry higher load values with less steel. Most wall openings can be supported with a single piece header and for wider openings an insert member is added for additional strength. The patented system utilizes an internal clip that fastens to the vertical Jamb stud(s). The ProX Header member snaps into place and leaves a flush surface for the application of drywall.

Material and labor costs are sharply reduced and construction productivity is increased. Installation is simplified and can be accomplished with a single framer. As with a traditional built-up box header the need to measure, cut and fit several stud and track components is eliminated. Additionally, there is no welding and much less screwing when using ProX Header.

Benefits

- IAPMO ER-0286.
- 2024, 2021 IBC & 2022 CBC code compliant.
- The ProX Header is engineered to deliver superior strength with fewer pieces.
- Easy, consistent installation – no welding required.
- Superior strength at connection points – internal ProX Header Clip design.
- Improved load values in lighter gauge materials.
- Straight cuts that deliver consistent and accurate fitting components.
- Reduces field cutting, welding and trimming.
- Consistent door and window header design for both interior and exterior metal framed openings.
- ProX Header offers a flush framing substrate that provides a better quality drywall finish.
- Easily insulates during the “work in progress.”
- Pre-engineered code compliant Span Tables.

LEED v4.1 – BD & C: Building Design and Construction – Materials and Resources

Building Life Cycle Impact Reduction (up to 4 points)

- Option 3: Building and Material Reuse
- 2 points for 25% reuse
- 3 points for 50% reuse
- 4 points for 75% reuse

Building Product Disclosure and Optimization – Environmental Product Declarations (up to 2 points)

- Option 1: Environmental Product Declaration (EPD)
- Option 2: Industry-wide EPD for cold-formed steel

Building Product Disclosure and Optimization – Sourcing of Raw Materials (up to 2 points)

- Option 1: Leadership Extraction Practices
- Option 2: Points based on recycled content of CFS products

Construction and Demolition Waste Management (up to 2 points)

- 1 point for 50% waste diversion
- 2 points for 75% waste diversion



Recycled Content

- Total Recycled Content: 36.9%
- Post-Consumer: 19.8%
- Pre-Consumer: 14.4%

California’s Proposition 65 Warning

California’s Safe Drinking Water and Toxic Enforcement Act of 1986 – commonly referred to as Proposition 65 (“Prop 65”) (27 Cal. Code Reg. § 25600, et seq.) – has recently changed, requiring manufacturers to provide a warning based on its knowledge about the presence of one or more of the almost 900 listed chemicals which are known to the State of California to cause cancer and birth defects, or other reproductive harm. With a few exceptions, manufacturers operating in the state of California as well as those entities who distribute, import, package, and/or supply products into the State of California are now required provide a “clear and reasonable” warning to consumers that their products may contain one or more of these listed chemicals or compounds. The complete list is available at www.P65Warnings.ca.gov.

In compliance with the new requirements, we are notifying each of our customers that CEMCO products contain Nickel (metallic) and/or other chemicals listed which are known to the State of California to cause cancer and birth defects or other reproductive harm. Safety data sheets from our major suppliers are available from CEMCO on our website at www.cemcosteel.com.

ProX Header Installation is Consistent, Fast, & Easy

The exploded assembly shows just how simple the ProX Header System is. The internal clip allows the ProX member to “Snap and Hold-in-Place” for fast installation and transfers loads to the vertical jamb studs. ProX is the fastest, easiest and the lowest installed cost, most efficient system for all rough openings. Code compliance is easily achieved when the ProX Header is used.

The ProX Header is made of 20, 18, 16 and 14 gauge (33, 43, 54 and 68 mil) galvanized steel complying with industry standard ASTM performance criteria for metal stud framing. The members fasten together with No. 8 (interior) or No. 10 (exterior) sheet metal screws (SMS). ProX Header Clips are internal and connect horizontal to vertical members, which leaves a smooth framing substrate for the drywall and finishing trades.

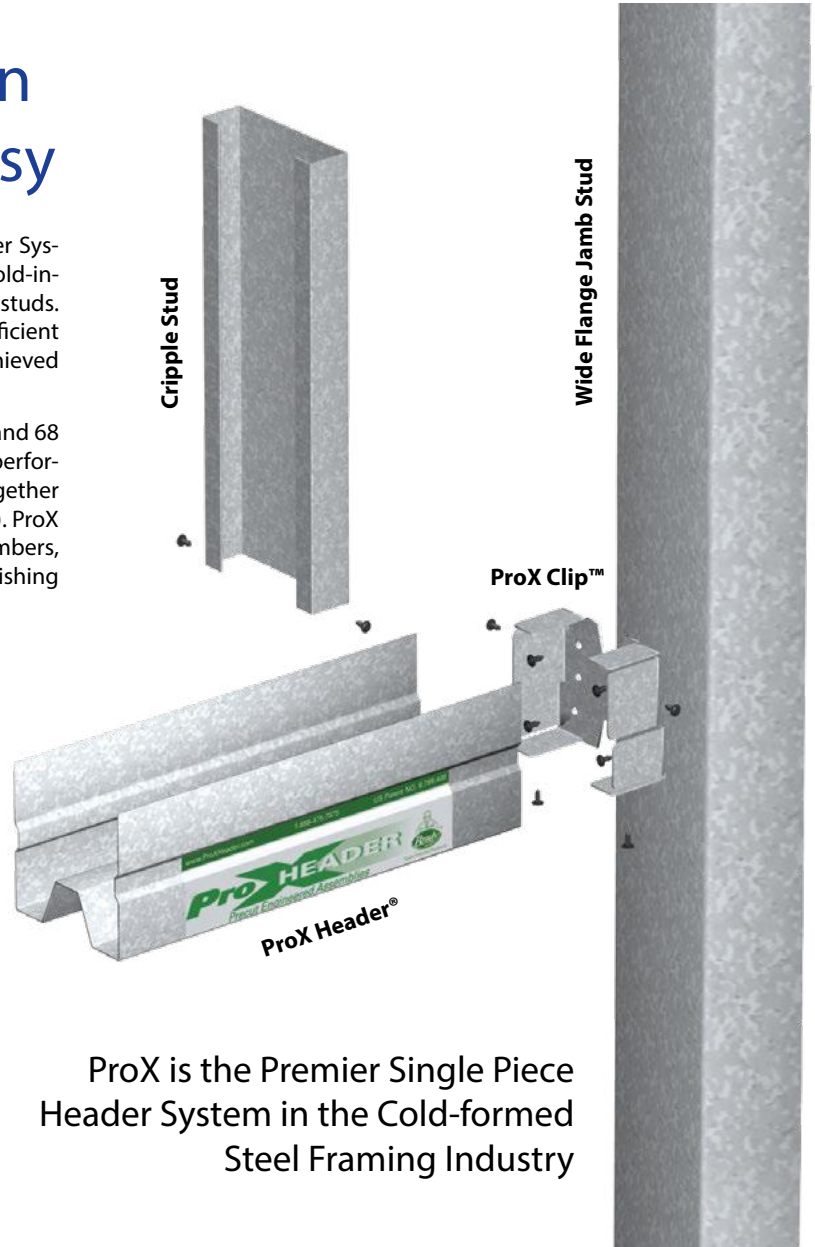

ProX is the Premier Single Piece Header System in the Cold-formed Steel Framing Industry

Watch ProX Header Component Assembly

Scan the code to see how simply the system components assemble to form a stronger header.



ProX Header Outer Sectional Properties

DESCRIPTION			GROSS SECTION PROPERTIES					EFFECTIVE PROPERTIES						TORSIONAL PROPERTIES			
Member Designation	Design Steel Thickness (in)	Weight (lbs./ft.)	Area (in ²)	I _x (in ⁴)	R _x (in)	I _y (in ⁴)	R _y (in)	I _x Pos. (in ⁴)	I _x Neg. (in ⁴)	I _y (in ⁴)	S _x Pos. (in ³)	S _x Neg. (in ³)	S _y (in ³)	Y _o (in)	J (in ⁴)	C _w (in ⁶)	R _o (in)
362X425-33	0.0346	1.6610	0.48853	0.7487	1.2380	1.1067	1.5051	0.36990	0.74869	0.83181	0.12191	0.27855	0.39064	-2.0762	0.0001950	2.2738	2.8475
362X425-43	0.0451	2.1519	0.63291	0.9608	1.2321	1.4110	1.4931	0.5540	0.9608	1.11330	0.18766	0.35931	0.53793	-2.0665	0.0004291	2.8719	2.8316
362X425-54	0.0566	2.6752	0.78683	1.1819	1.2256	1.7236	1.4800	0.6840	1.1819	1.33250	0.23334	0.44490	0.64169	-2.0610	0.0008402	3.4670	2.8178
362X425-68	0.0713	3.3271	0.97854	1.4497	1.2172	2.0953	1.4633	0.9944	1.4497	1.70130	0.35150	0.55050	0.84590	-2.0551	0.0016582	4.1490	2.8011
400X425-33	0.0346	1.7051	0.50151	0.7789	1.2462	1.3605	1.6471	0.3879	0.7789	1.02600	0.12637	0.28552	0.43849	-2.1374	0.0002001	2.8338	2.9722
400X425-43	0.0451	2.2094	0.64983	0.9998	1.2404	1.7374	1.6351	0.5800	0.9998	1.37410	0.19406	0.36838	0.60351	-2.1280	0.0004406	3.5851	2.9565
400X425-54	0.0566	2.7474	0.80806	1.2305	1.2340	2.1261	1.6221	0.7166	1.2305	1.64820	0.24140	0.45629	0.72125	-2.1228	0.0008629	4.3372	2.9428
400X425-68	0.0713	3.4180	1.0053	1.5106	1.2258	2.5909	1.6054	1.0404	1.5106	2.10770	0.36280	0.56490	0.95090	-2.1171	0.0017035	5.2054	2.9261
600X425-33	0.0346	1.9404	0.57071	0.9168	1.2674	3.2507	2.3866	0.4686	0.9168	2.46650	0.14507	0.31498	0.71069	-2.2394	0.0002277	6.9805	3.5096
600X425-43	0.0451	2.5161	0.74003	1.1779	1.2616	4.1732	2.3747	0.6968	1.1779	3.35460	0.22090	0.40660	0.99690	-2.2301	0.0005017	8.8786	3.4935
600X425-54	0.0566	3.1323	0.92126	1.4520	1.2556	5.1380	2.3616	0.8626	1.4524	4.05660	0.27520	0.50420	1.20030	-2.2238	0.0009838	10.8150	3.4784
600X425-68	0.0713	3.9028	1.1479	1.7880	1.2479	6.3120	2.3449	1.2472	1.7877	5.20550	0.41020	0.62520	1.57920	-2.2165	0.0019450	13.1010	3.4596

For SI: 1 inch = 25.4 mm, 1 mil = 0.0254mm, 1 lb = 4.45 N.

ProX Header Outer Allowable Values

DESCRIPTION			ALLOWABLE VALUES			
Member Designation	Design Steel Thickness (in)	Weight (lbs./ft.)	Positive Moment +Ma (in.-lbs.)		Negative Moment -Ma (in.-lbs.)	
			X-Axis	Y-Axis	X-Axis	Y-Axis
362X425-33	0.0346	1.6610	2,409	5,695	5,504	5,695
362X425-43	0.0451	2.1519	3,708	8,232	7,100	8,232
362X425-54	0.0566	2.6752	6,986	14,309	13,320	14,309
362X425-68	0.0713	3.3271	10,524	19,735	16,483	19,735
400X425-33	0.0346	1.7051	2,497	6,096	5,642	6,096
400X425-43	0.0451	2.2094	3,835	8,841	7,279	8,841
400X425-54	0.0566	2.7474	7,228	15,396	13,661	15,396
400X425-68	0.0713	3.4180	10,863	21,322	16,914	21,322
600X425-33	0.0346	1.9404	2,867	8,497	6,224	8,497
600X425-43	0.0451	2.5161	4,366	12,472	8,035	12,472
600X425-54	0.0566	3.1323	8,239	21,892	15,096	21,892
600X425-68	0.0713	3.9028	12,283	30,761	18,720	30,761

For SI: 1 inch = 25.4 mm, 1 mil = 0.0254mm, 1 lb = 4.45 N.

Notes:

1. Allowable moment values are governed by distortional buckling.

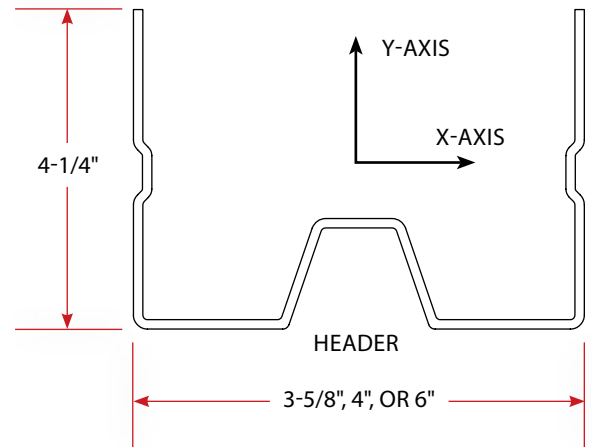

ProX Header Clip Allowable Values: Without Insert, #8 Screw

ProX Header Outer Widths (in)	ProX Header Thickness (in)	Number of Fasteners Attaching ProX Clip to Vertical Rough Opening Support	Number of Screws Attaching ProX Header Outer to Clip	Allowable Values (pounds)	
				V (vertical)	V (horizontal)
3.625	33	4	4	400	472
3.625	43	4	4	573	492
3.625	54	4	4	726	514
3.625	68	4	4	726	514
4.000	33	4	4	400	523
4.000	43	4	4	573	690
4.000	54	4	4	783	719
4.000	68	4	4	783	719
6.000	33	6	4	492	538
6.000	43	6	4	704	709
6.000	54	6	4	963	921
6.000	68	6	4	963	921

For SI: 1 inch = 25.4 mm, 1 mil = 0.0254mm, 1 lb = 4.45 N.

Notes:

- Jamb member thickness to match or exceed ProX Header thickness.
- Locate the screws from clip to jamb at the four corner holes of the clip when supporting a ProX Header without insert. At clips with 10 screw holes, fill the center two holes as well (6 total). At ProX Header with Insert fill all holes.
- Maximum gap between end of header and jamb to be ¼ inch.
- All clips are 54 mils.
- Values may not be increased by 33% for load combinations involving wind or seismic.

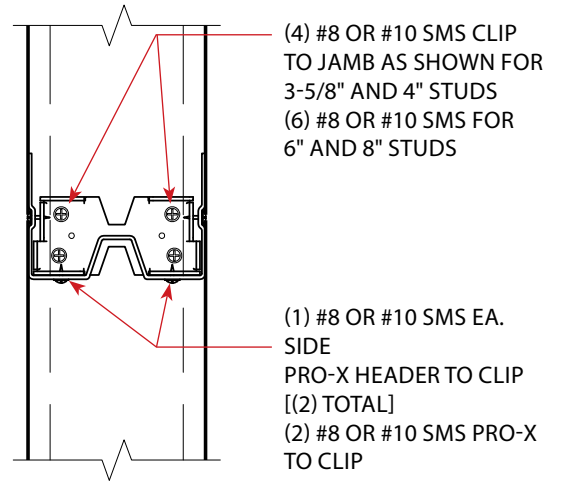

PRO-X HEADER WITHOUT INSERT TO JAMB

ProX Header Clip Allowable Values: Without Insert, #10 Screw

ProX Header Outer Widths (in)	ProX Header Thickness (in)	Number of Fasteners Attaching ProX Clip to Vertical Rough Opening Support	Number of Screws Attaching ProX Header Outer to Clip	Allowable Values (pounds)	
				V (vertical)	V (horizontal)
3.625	33	4	4	442	483
3.625	43	4	4	631	506
3.625	54	4	4	793	531
3.625	68	4	4	793	531
4.000	33	4	4	442	558
4.000	43	4	4	631	711
4.000	54	4	4	861	734
4.000	68	4	4	861	734
6.000	33	6	4	544	574
6.000	43	6	4	775	759
6.000	54	6	4	1054	989
6.000	68	6	4	1054	989

For SI: 1 inch = 25.4 mm, 1 mil = 0.0254mm, 1 lb = 4.45 N.

Notes:

- Jamb member thickness to match or exceed ProX Header thickness.
- Locate the screws from clip to jamb at the four corner holes of the clip when supporting a ProX Header without insert. At clips with 10 screw holes, fill the center two holes as well (6 total). At ProX Header with Insert fill all holes.
- Maximum gap between end of header and jamb to be ¼ inch.
- All clips are 54 mils.
- Values may not be increased by 33% for load combinations involving wind or seismic.

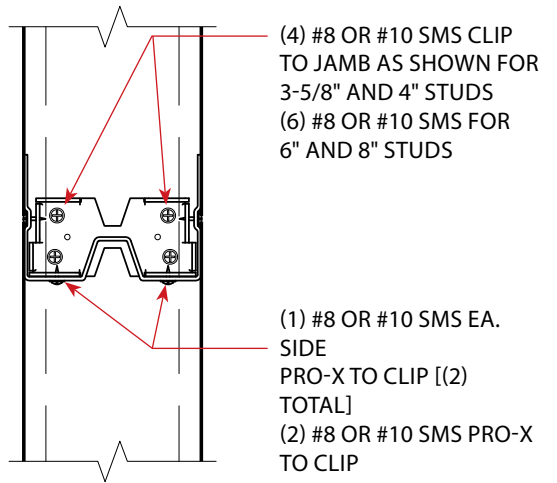

PRO-X HEADER WITHOUT INSERT TO JAMB

Table 9: Interior Header Schedule – IAPMO ER-0286 (IBC 2024, 2021 & CBC 2022)
For use at 1-hour walls; 5/8" drywall full height each side of the wall. $I_p = 1.0$ & $S_{DS} = 2.48$ (max) or $I_p = 1.5$ & $S_{DS} = 1.65$ (max)
BUILDING CODE COMPLIANCE: IBC 2024, 2021 & CBC 2022

 Out-of-plane loading to be 5 psf min. per IBC or CBC Section 1607.14 or as determined by the building parameters. The use of this chart is acceptable for the Importance Factor, $I_p = 1.0$ and Spectral Response Acceleration, $S_{DS} = 2.48$ (max), OR Importance Factor $I_p = 1.5$ and Spectral Response Acceleration, $S_{DS} = 1.65$ (max). This chart is also valid for Design Categories A-F. Deflection L/240 – One (1) layer gypsum board (each side) = 6 psf wall height - 5 psf transverse pressure - 24" o.c. (max) Stud Spacing

Opening Type	Deck Height	Wall Width Stud Size	ALLOWABLE SPAN: PRO-X HEADER SELECTION – INTERIOR OPENING SPAN				
			0' – 4' 6"	4' 7" – 6' 6"	6' 7" – 8' 6"	8' 7" – 10' 6"	10' 7" – 12' 0"
Typical Interior Door (or) Window HEAD @ 7'-0" tall or greater	UP TO 14' 0"	3-5/8" Studs = 362	362X425-33	362X425-43	362X425-54	362X425-68	N/A
		4" Studs = 400	400X425-33	400X425-43	400X425-54	400X425-68	N/A
		6" Studs = 600	600X425-33	600X425-43	600X425-54	600X425-68	600X425-68
	14' 1" – 16' 0"	3-5/8" Studs = 362	362X425-33	362X425-54	362X425-68	N/A	N/A
		4" Studs = 400	400X425-33	400X425-54	400X425-68	N/A	N/A
		6" Studs = 600	600X425-33	600X425-43	600X425-54	600X425-68	N/A
	16' 1" – 18' 0"	3-5/8" Studs = 362	362X425-43	362X425-54	362X425-68	N/A	N/A
		4" Studs = 400	400X425-43	400X425-54	400X425-68	N/A	N/A
		6" Studs = 600	600X425-33	600X425-54	600X425-68	N/A	N/A
	18' 1" – 20' 0"	3-5/8" Studs = 362	362X425-43	362X425-54	N/A	N/A	N/A
		4" Studs = 400	400X425-43	400X425-54	N/A	N/A	N/A
		6" Studs = 600	600X425-43	600X425-54	600X425-68	N/A	N/A

 For Sl: 1 inch = 25.4 mm, 1 mil = 0.0254 mm, 1 psf = 4.88 kg/m².

Notes:

- All Screws used to attach clips to jamb studs are No.8 Self-Tapping Waferhead Screws. No. 10 SMS (min. 3/4" long) are required at all 68 mil applications. Tables 7A, 7B, 8A, and 8B specify the number of screws in clip to jamb stud and header to clip.
- All Clips are 54 mil. / 16 gauge / All Fasteners / Screws can be installed in either direction (i.e. Clip to Jamb or Jamb to Clip)
- Product Nomenclature: Series X = ProX Header Member "without" insert i.e.: 362X425 - Series XTC = ProX Header Member "with" insert - i.e.: 362XTC425
- Product Nomenclature: 33mil. = 20 gauge, 43mil. = 18 gauge, 54mil. = 16 gauge, 68mil. = 14 gauge - i.e.: 362X425-54 = 16 gauge member
- The allowable transverse pressure of 5.0 psf is the maximum air pressure (such as in shaft walls) and also the maximum "Seismic Design Force" based on wall weight when using the IP and SDS in the Table above.

Table 10: Interior Header Schedule – IAPMO ER-0286 (IBC 2024, 2021 & CBC 2022)
For use at 1-hour walls; 5/8" drywall full height each side of the wall. $I_p = 1.0$ & $S_{DS} = 3.72$ (max) or $I_p = 1.5$ & $S_{DS} = 2.48$ (max)
BUILDING CODE COMPLIANCE: IBC 2024, 2021 & CBC 2022

 Out-of-plane loading to be 5 psf min. per IBC or CBC Section 1607.14 or as determined by the building parameters. The use of this chart is acceptable for the Importance Factor, $I_p = 1.0$ and Spectral Response Acceleration, $S_{DS} = 3.72$ (max), OR Importance Factor $I_p = 1.5$ and Spectral Response Acceleration, $S_{DS} = 2.48$ (max). This chart is also valid for Design Categories A-F. Deflection L/240 – One (1) layer gypsum board (each side) = 6 psf wall height - 7.5 psf transverse pressure - 24" o.c. (max) Stud Spacing

Opening Type	Deck Height	Wall Width Stud Size	ALLOWABLE SPAN: PRO-X HEADER SELECTION – INTERIOR OPENING SPAN				
			0' – 4' 6"	4' 7" – 6' 6"	6' 7" – 8' 6"	8' 7" – 10' 6"	10' 7" – 12' 0"
Typical Interior Door (or) Window HEAD @ 7'-0" tall or greater	UP TO 14' 0"	3-5/8" Studs = 362	362X425-33	362X425-54	362X425-68	N/A	N/A
		4" Studs = 400	400X425-33	400X425-54	400X425-54	N/A	N/A
		6" Studs = 600	600X425-33	600X425-43	600X425-54	600X425-68	N/A
	14' 1" – 16' 0"	3-5/8" Studs = 362	362X425-43	362X425-54	362X425-68	N/A	N/A
		4" Studs = 400	400X425-33	400X425-54	400X425-68	N/A	N/A
		6" Studs = 600	600X425-33	600X425-54	600X425-68	N/A	N/A
	16' 1" – 18' 0"	3-5/8" Studs = 362	362X425-43	362X425-54	N/A	N/A	N/A
		4" Studs = 400	400X425-43	400X425-54	N/A	N/A	N/A
		6" Studs = 600	600X425-33	600X425-54	600X425-68	N/A	N/A
	18' 1" – 20' 0"	3-5/8" Studs = 362	362X425-43	362X425-68	N/A	N/A	N/A
		4" Studs = 400	400X425-43	400X425-54	N/A	N/A	N/A
		6" Studs = 600	600X425-43	600X425-54	600X425-68	N/A	N/A

 For Sl: 1 inch = 25.4 mm, 1 mil = 0.0254 mm, 1 psf = 4.88 kg/m².

Notes:

- All Screws used to attach clips to jamb studs are No.8 Self-Tapping Waferhead Screws. No. 10 SMS (min. 3/4" long) are required at all 68 mil applications. Tables 7A, 7B, 8A, and 8B specify the number of screws in clip to jamb stud and header to clip.
- All Clips are 54 mil. / 16 gauge / All Fasteners / Screws can be installed in either direction (i.e. Clip to Jamb or Jamb to Clip)
- Product Nomenclature: Series X = ProX Header Member "without" insert i.e.: 362X425 - Series XTC = ProX Header Member "with" insert - i.e.: 362XTC425
- Product Nomenclature: 33mil. = 20 gauge, 43mil. = 18 gauge, 54mil. = 16 gauge, 68mil. = 14 gauge - i.e.: 362X425-54 = 16 gauge member
- The allowable transverse pressure of 7.5 psf is the maximum air pressure (such as in shaft walls) and also the maximum "Seismic Design Force" based on wall weight when using the IP and SDS in the Table above.

Table 11: Interior Header Schedule – IAPMO ER-0286 (IBC 2024, 2021 & CBC 2022)

For use at 2-hour walls; 5/8" drywall full height each side of the wall. $I_p = 1.0$ & $S_{DS} = 4.97$ (max) or $I_p = 1.5$ & $S_{DS} = 3.31$ (max)

BUILDING CODE COMPLIANCE: IBC 2024, 2021 & CBC 2022
 Out-of-plane loading to be 5 psf min. per IBC or CBC Section 1607.14 or as determined by the building parameters. The use of this chart is acceptable for the Importance Factor, $I_p = 1.0$ and Spectral Response Acceleration, $S_{DS} = 4.97$ (max), OR Importance Factor $I_p = 1.5$ and Spectral Response Acceleration, $S_{DS} = 3.31$ (max). This chart is also valid for Design Categories A-F. Deflection L/240 – One (1) layer gypsum board (each side) = 6 psf wall height - 10.0 psf transverse pressure - 24" o.c. (max) Stud Spacing

Opening Type	Deck Height	Wall Width Stud Size	ALLOWABLE SPAN: PRO-X HEADER SELECTION – INTERIOR OPENING SPAN				
			0' – 4' 6"	4' 7" – 6' 6"	6' 7" – 8' 6"	8' 7" – 10' 6"	10' 7" – 12' 0"
Typical Interior Door (or) Window HEAD @ 7'-0" tall or greater	UP TO 14' 0"	3-5/8" Studs = 362	362X425-33	362X425-54	362X425-68	N/A	N/A
		4" Studs = 400	400X425-33	400X425-54	400X425-68	N/A	N/A
		6" Studs = 600	600X425-33	600X425-43	600X425-54	600X425-68	N/A
	14' 1" – 16' 0"	3-5/8" Studs = 362	362X425-43	362X425-54	362X425-68	N/A	N/A
		4" Studs = 400	400X425-43	400X425-54	400X425-68	N/A	N/A
		6" Studs = 600	600X425-33	600X425-54	600X425-68	N/A	N/A
	16' 1" – 18' 0"	3-5/8" Studs = 362	362X425-43	362X425-54	N/A	N/A	N/A
		4" Studs = 400	400X425-43	400X425-54	N/A	N/A	N/A
		6" Studs = 600	600X425-33	600X425-54	600X425-68	N/A	N/A
	18' 1" – 20' 0"	3-5/8" Studs = 362	362X425-54	362X425-68	N/A	N/A	N/A
		4" Studs = 400	400X425-43	400X425-68	N/A	N/A	N/A
		6" Studs = 600	600X425-43	600X425-54	N/A	N/A	N/A

For Sl: 1 inch = 25.4 mm, 1 mil = 0.0254 mm, 1 psf = 4.88 kg/m².

Notes:

- All Screws used to attach clips to jamb studs are No.8 Self-Tapping Waferhead Screws. No. 10 SMS (min. 3/4" long) are required at all 68 mil applications. Tables 7A, 7B, 8A, and 8B specify the number of screws in clip to jamb stud and header to clip.
- All Clips are 54 mil. / 16 gauge / All Fasteners / Screws can be installed in either direction (i.e. Clip to Jamb or Jamb to Clip)
- Product Nomenclature: Series X = ProX Header Member "without" insert i.e.: 362X425 - Series XTC = ProX Header Member "with" insert - i.e.: 362XTC425
- Product Nomenclature: 33mil. = 20 gauge, 43mil. = 18 gauge, 54mil. = 16 gauge, 68mil. = 14 gauge - i.e.: 362X425-54 = 16 gauge member
- The allowable transverse pressure of 10.0 psf is the maximum air pressure (such as in shaft walls) and also the maximum "Seismic Design Force" based on wall weight when using the IP and SDS in the Table above.

Table 12: Interior Header Schedule – IAPMO ER-0286 (IBC 2024, 2021 & CBC 2022)

For use at 2-hour walls; two layers of 5/8" drywall full height each side of the wall. $I_p = 1.0$ & $S_{DS} = 1.35$ (max) or $I_p = 1.5$ & $S_{DS} = 0.902$ (max)

BUILDING CODE COMPLIANCE: IBC 2024, 2021 & CBC 2022
 Out-of-plane loading to be 5 psf min. per IBC or CBC Section 1607.14 or as determined by the building parameters. The use of this chart is acceptable for the Importance Factor, $I_p = 1.0$ and Spectral Response Acceleration, $S_{DS} = 1.35$ (max), OR Importance Factor $I_p = 1.5$ and Spectral Response Acceleration, $S_{DS} = 0.902$ (max). This chart is also valid for Design Categories A-F. Deflection L/240 – Two (2) layers gypsum board (each side) = 11 psf wall height - 5 psf transverse pressure - 24" o.c. (max) Stud Spacing

Opening Type	Deck Height	Wall Width Stud Size	ALLOWABLE SPAN: PRO-X HEADER SELECTION – INTERIOR OPENING SPAN				
			0' – 4' 6"	4' 7" – 6' 6"	6' 7" – 8' 6"	8' 7" – 10' 6"	10' 7" – 12' 0"
Typical Interior Door (or) Window HEAD @ 7'-0" tall or greater	UP TO 14' 0"	3-5/8" Studs = 362	362X425-43	362X425-54	362X425-68	N/A	N/A
		4" Studs = 400	400X425-43	400X425-54	400X425-68	N/A	N/A
		6" Studs = 600	600X425-33	600X425-54	600X425-68	N/A	N/A
	14' 1" – 16' 0"	3-5/8" Studs = 362	362X425-43	362X425-68	N/A	N/A	N/A
		4" Studs = 400	400X425-43	400X425-68	N/A	N/A	N/A
		6" Studs = 600	600X425-43	600X425-54	N/A	N/A	N/A
	16' 1" – 18' 0"	3-5/8" Studs = 362	362X425-54	362X425-68	N/A	N/A	N/A
		4" Studs = 400	400X425-54	400X425-68	N/A	N/A	N/A
		6" Studs = 600	600X425-43	600X425-68	N/A	N/A	N/A
	18' 1" – 20' 0"	3-5/8" Studs = 362	362X425-54	N/A	N/A	N/A	N/A
		4" Studs = 400	400X425-54	400X425-68	N/A	N/A	N/A
		6" Studs = 600	600X425-54	600X425-68	N/A	N/A	N/A

For Sl: 1 inch = 25.4 mm, 1 mil = 0.0254 mm, 1 psf = 4.88 kg/m².

Notes:

- All Screws used to attach clips to jamb studs are No. 8 Self-Tapping Waferhead Screws. No. 10 SMS (min. 3/4" long) are required at all 68 mil applications. Tables 7A, 7B, 8A, and 8B specify the number of screws in clip to jamb stud and header to clip.
- All Clips are 54 mil. / 16 gauge / All Fasteners / Screws can be installed in either direction (i.e. Clip to Jamb or Jamb to Clip)
- Product Nomenclature: Series X = ProX Header Member "without" insert i.e.: 362X425 - Series XTC = ProX Header Member "with" insert - i.e.: 362XTC425
- Product Nomenclature: 33mil. = 20 gauge, 43mil. = 18 gauge, 54mil. = 16 gauge, 68mil. = 14 gauge - i.e.: 362X425-54 = 16 gauge member
- The allowable transverse pressure of 5.0 psf is the maximum air pressure (such as in shaft walls) and also the maximum "Seismic Design Force" based on wall weight when using the IP and SDS in the Table above.

Table 13: Interior Header Schedule – IAPMO ER-0286 (IBC 2024, 2021 & CBC 2022)
For use at 2-hour walls; two layers of 5/8" drywall full height each side of the wall. $I_p = 1.0$ & $S_{DS} = 2.03$ (max) or $I_p = 1.5$ & $S_{DS} = 4.97$ (max)
BUILDING CODE COMPLIANCE: IBC 2024, 2021 & CBC 2022

 Out-of-plane loading to be 5 psf min. per IBC or CBC Section 1607.14 or as determined by the building parameters. The use of this chart is acceptable for the Importance Factor, $I_p = 1.0$ and Spectral Response Acceleration, $S_{DS} = 2.03$ (max), OR Importance Factor $I_p = 1.5$ and Spectral Response Acceleration, $S_{DS} = 1.35$ (max). This chart is also valid for Design Categories A-F. Deflection $L/240$ – One (1) layer gypsum board (each side) = 11 psf wall height - 7.5 psf transverse pressure - 24" o.c. (max) Stud Spacing

Opening Type	Deck Height	Wall Width Stud Size	ALLOWABLE SPAN: PRO-X HEADER SELECTION – INTERIOR OPENING SPAN				
			0' – 4' 6"	4' 7" – 6' 6"	6' 7" – 8' 6"	8' 7" – 10' 6"	10' 7" – 12' 0"
Typical Interior Door (or) Window HEAD @ 7'-0" tall or greater	UP TO 14' 0"	3-5/8" Studs = 362	362X425-43	362X425-54	N/A	N/A	N/A
		4" Studs = 400	400X425-43	400X425-54	N/A	N/A	N/A
		6" Studs = 600	600X425-43	600X425-54	600X425-68	N/A	N/A
	14' 1" – 16' 0"	3-5/8" Studs = 362	362X425-54	362X425-68	N/A	N/A	N/A
		4" Studs = 400	400X425-43	400X425-68	N/A	N/A	N/A
		6" Studs = 600	600X425-43	600X425-54	N/A	N/A	N/A
	16' 1" – 18' 0"	3-5/8" Studs = 362	362X425-54	362X425-68	N/A	N/A	N/A
		4" Studs = 400	400X425-54	400X425-68	N/A	N/A	N/A
		6" Studs = 600	600X425-54	600X425-68	N/A	N/A	N/A
	18' 1" – 20' 0"	3-5/8" Studs = 362	362X425-54	N/A	N/A	N/A	N/A
		4" Studs = 400	400X425-54	N/A	N/A	N/A	N/A
		6" Studs = 600	600X425-54	600X425-68	N/A	N/A	N/A

 For Sl: 1 inch = 25.4 mm, 1 mil = 0.0254 mm, 1 psf = 4.88 kg/m².

Notes:

- All Screws used to attach clips to jamb studs are No. 8 Self-Tapping Waferhead Screws. No. 10 SMS (min. 3/4" long) are required at all 68 mil applications. Tables 7A, 7B, 8A, and 8B specify the number of screws in clip to jamb stud and header to clip.
- All Clips are 54 mil. / 16 gauge / All Fasteners / Screws can be installed in either direction (i.e. Clip to Jamb or Jamb to Clip)
- Product Nomenclature: Series X = ProX Header Member "without" insert i.e.: 362X425 - Series XTC = ProX Header Member "with" insert - i.e.: 362XTC425
- Product Nomenclature: 33mil. = 20 gauge, 43mil. = 18 gauge, 54mil. = 16 gauge, 68mil. = 14 gauge - ie: 362X425-54 = 16 gauge member
- The allowable transverse pressure of 7.5 psf is the maximum air pressure (such as in shaft walls) and also the maximum "Seismic Design Force" based on wall weight when using the IP and SDS in the Table above.

Table 14: Interior Header Schedule – IAPMO ER-0286 (IBC 2024, 2021 & CBC 2022)
For use at 2-hour walls; two layers of 5/8" drywall full height each side of the wall. $I_p = 1.0$ & $S_{DS} = 2.70$ (max) or $I_p = 1.5$ & $S_{DS} = 1.80$ (max)
BUILDING CODE COMPLIANCE: IBC 2024, 2021 & CBC 2022

 Out-of-plane loading to be 5 psf min. per IBC or CBC Section 1607.14 or as determined by the building parameters. The use of this chart is acceptable for the Importance Factor, $I_p = 1.0$ and Spectral Response Acceleration, $S_{DS} = 2.70$ (max), OR Importance Factor $I_p = 1.5$ and Spectral Response Acceleration, $S_{DS} = 1.80$ (max). This chart is also valid for Design Categories A-F. Deflection $L/240$ – One (1) layer gypsum board (each side) = 11 psf wall height - 10.0 psf transverse pressure - 24" o.c. (max) Stud Spacing

Opening Type	Deck Height	Wall Width Stud Size	ALLOWABLE SPAN: PRO-X HEADER SELECTION – INTERIOR OPENING SPAN				
			0' – 4' 6"	4' 7" – 6' 6"	6' 7" – 8' 6"	8' 7" – 10' 6"	10' 7" – 12' 0"
Typical Interior Door (or) Window HEAD @ 7'-0" tall or greater	UP TO 14' 0"	3-5/8" Studs = 362	362X425-43	362X425-68	N/A	N/A	N/A
		4" Studs = 400	400X425-43	400X425-54	N/A	N/A	N/A
		6" Studs = 600	600X425-43	600X425-54	600X425-68	N/A	N/A
	14' 1" – 16' 0"	3-5/8" Studs = 362	362X425-54	362X425-68	N/A	N/A	N/A
		4" Studs = 400	400X425-54	400X425-68	N/A	N/A	N/A
		6" Studs = 600	600X425-43	600X425-54	N/A	N/A	N/A
	16' 1" – 18' 0"	3-5/8" Studs = 362	362X425-54	N/A	N/A	N/A	N/A
		4" Studs = 400	400X425-54	400X425-68	N/A	N/A	N/A
		6" Studs = 600	600X425-54	600X425-68	N/A	N/A	N/A
	18' 1" – 20' 0"	3-5/8" Studs = 362	362X425-54	N/A	N/A	N/A	N/A
		4" Studs = 400	400X425-54	N/A	N/A	N/A	N/A
		6" Studs = 600	600X425-54	600X425-68	N/A	N/A	N/A

 For Sl: 1 inch = 25.4 mm, 1 mil = 0.0254 mm, 1 psf = 4.88 kg/m².

Notes:

- All Screws used to attach clips to jamb studs are No. 8 Self-Tapping Waferhead Screws. No. 10 SMS (min. 3/4" long) are required at all 68 mil applications. Tables 7A, 7B, 8A, and 8B specify the number of screws in clip to jamb stud and header to clip.
- All Clips are 54 mil. / 16 gauge / All Fasteners / Screws can be installed in either direction (i.e. Clip to Jamb or Jamb to Clip)
- Product Nomenclature: Series X = ProX Header Member "without" insert i.e.: 362X425 - Series XTC = ProX Header Member "with" insert - i.e.: 362XTC425
- Product Nomenclature: 33mil. = 20 gauge, 43mil. = 18 gauge, 54mil. = 16 gauge, 68mil. = 14 gauge - ie: 362X425-54 = 16 gauge member
- The allowable transverse pressure of 10.0 psf is the maximum air pressure (such as in shaft walls) and also the maximum "Seismic Design Force" based on wall weight when using the IP and SDS in the Table above.



Expanding Your Solutions

Corporate Headquarters

13191 Crossroads Parkway North, Suite 325, City of Industry, CA 91746

P: 800.775.2362 | **F:** 626.330.7598

Southern California Manufacturing Facility

263 North Covina Lane, City of Industry, CA 91746

P: 800.775.2362 | **F:** 626.330.7598

Northern California Manufacturing Facility

1001-A Pittsburg Antioch Hwy, Pittsburg, CA 94565

P: 925.473.9340 | **F:** 925.473.9341

Commerce City Colorado Manufacturing Facility

9410 Heinz Way, Commerce City, CO 80640

P: 303.572.3626 | **F:** 303.572.3627

Fort Worth Texas Manufacturing Facility

8600 Will Rogers Blvd, Fort Worth, TX 76140

P: 817.568.1525 | **F:** 817.568.2759

www.cemcosteel.com



Effective 01/27/2025

