



Expanding Your Solutions®

800.775.2362 | www.cemcosteel.com

Structural Engineering/Design: 925.473.9340

Technical Services: 800.416.2278

FAS STRAP™

Product Description

CEMCO FAS STRAP is an accessory preformed galvanized steel strap with 2 intumescent strips for use as a flute cover when fire-rated walls run parallel to the flutes. FAS STRAP eliminates the need for mineral wool flute fillers and bridging for attachment of the top track to the underside of the deck. The FAS STRAP is fabricated from hot-dipped galvanized steel. It is UL tested and listed and can be used as a component of 1 & 2 hour fire-resistant joint systems.



Ordering / Packaging

Description	Part #	Width	Length	Pcs/Ctn	Deck Application	Submitted for Review/Use	✓
FAS STRAP (20 ga)	FASTP675033	6-3/4"	10'	EACH*	1-1/2" Tall Flutes	FASTP675033	
FAS STRAP (18 ga)	FASTP675043	6-3/4"	10'	EACH*		FASTP675043	
FAS STRAP (20 ga)	FASTP825033	8-1/4"	10'	EACH*	2" Tall Flutes	FASTP825033	
FAS STRAP (18 ga)	FASTP825043	8-1/4"	10'	EACH*		FASTP825043	
FAS STRAP (20 ga)	FASTP105033	10-1/2"	10'	EACH*	3" Tall Flutes	FASTP105033	
FAS STRAP (18 ga)	FASTP105043	10-1/2"	10'	EACH*		FASTP105043	

* Contact CEMCO for minimum order quantity.

Storage / Warranty

- When stored indoors and kept dry in its original package and condition, FAS STRAP has an unlimited shelf life.
- 25 Year Limited Warranty – see CEMCO Standard Fire, Smoke & Acoustic Product Warranty for details.

ASTM & Code Standards

- AISI S100
- AISI S220
- ASTM E84
- ASTM A653
- ASTM A924
- ASTM A1003
- ASTM C645
- ASTM E1966
- UL 2079 5th Edition
- UL ER25033-01
- L-Rating (air leakage) testing for compliance with International Building Code (IBC) and Canadian Building Code (CBC).
- UL listings/approvals include: HW-D-0524; HW-D-0587
- U.S. Patent No.10,214,901**

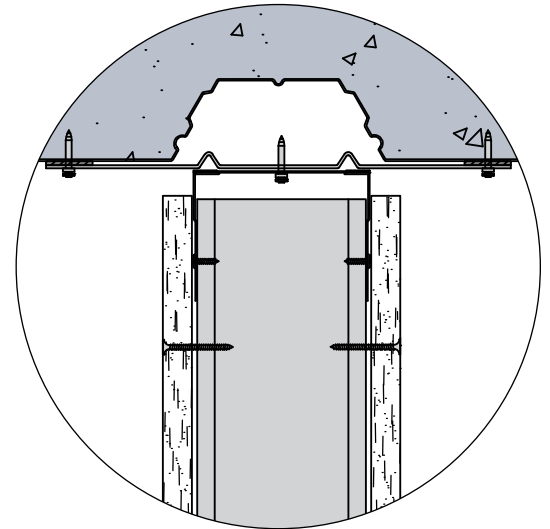

Please refer to www.cemcosteel.com for [UL Fire Rated Assemblies](#) and [Sound Test Reports](#).



This technical information reflects the most current information available and supersedes any and all previous publications effective June 15, 2026.

06-15-26 AT



Expanding Your Solutions®

800.775.2362 | www.cemcosteel.com

Structural Engineering/Design: 925.473.9340

Technical Services: 800.416.2278

FAS STRAP™

FASTP675033 / FASTP675043

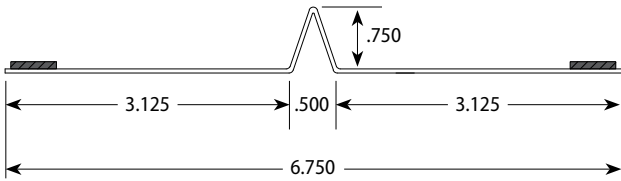
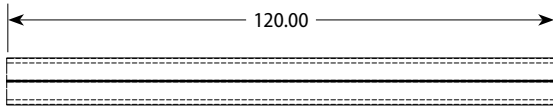

FASTP825033 / FASTP825043

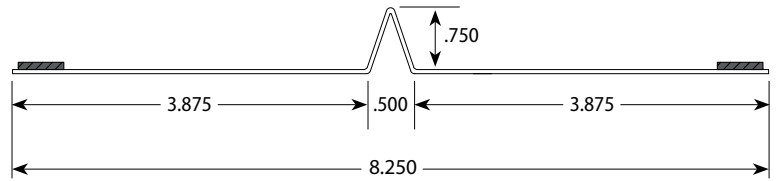
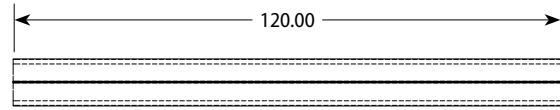

FASTP105033 / FASTP105043

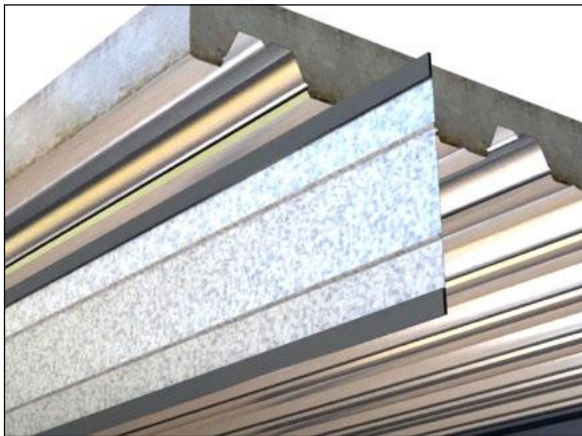
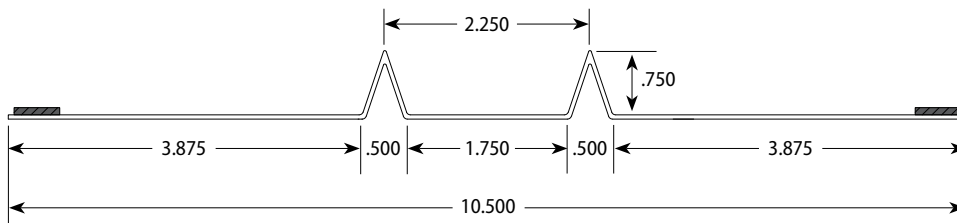
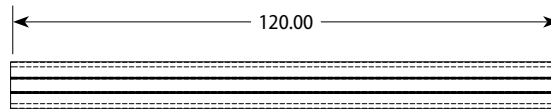

←
**View the
installation
video!**

Please refer to www.cemcosteel.com for [UL Fire Rated Assemblies](#) and [Sound Test Reports](#).



This technical information reflects the most current information available and supersedes any and all previous publications effective June 15, 2026.

06-15-26 AT