

ICC-ES Evaluation Report

ESR-2012

Reissued October 2025

This report also contains:

- [City of LA Supplement](#)

Subject to renewal October 2026

- [CA Supplement w/ DSA and OSHPD](#)

ICC-ES Evaluation Reports are not to be construed as representing aesthetics or any other attributes not specifically addressed, nor are they to be construed as an endorsement of the subject of the report or a recommendation for its use. There is no warranty by ICC Evaluation Service, LLC, express or implied, as to any finding or other matter in this report, or as to any product covered by the report.

Copyright © 2025 ICC Evaluation Service, LLC. All rights reserved.

<p>DIVISION: 05 00 00 — METALS</p> <p>Section: 05 40 00 — Cold-Formed Metal Framing</p> <p>DIVISION: 09 00 00 — FINISHES</p> <p>Section: 09 22 16.13 — Non-Structural Metal Stud Framing</p>	<p>REPORT HOLDER: CEMCO, LLC.</p>	<p>EVALUATION SUBJECT: CEMCO STEEL TRACKS EXPANSION JOINT SYSTEM FOR NONLOAD-BEARING WALL SYSTEMS</p>	
--	--	--	---

1.0 EVALUATION SCOPE

Compliance with the following code:

2021, 2018 and 2015 [International Building Code® \(IBC\)](#)

Property evaluated:

Structural

2.0 USES

CEMCO Slotted Tracks are deflection tracks that are recognized for use in nonload-bearing, light-gage steel framed wall assemblies. CEMCO Slotted Tracks are part of the Expansion Joint System, which provides a gap at the top of the wall to accommodate vertical movement of the building caused by seismic, wind or other loads.

3.0 DESCRIPTION

3.1 General:

The CEMCO slotted Tracks are available with drift slots in the web (CST-W) and without drift slots in the web (CST, CST-300, and CST-325).

3.2 CST and CST-W Tracks:

The CST deflection tracks are U-shaped channel sections with slotted flanges and are formed from cold-formed sheet steel. The CST sections have widths of 2¹/₂, 3⁵/₈, 4, 6, and 8 inches (64, 92, 102, 152 and 203 mm) and are cold-formed from steel having design thicknesses of 0.0188, 0.0312, 0.0346, 0.0451, 0.0566, and 0.0713 inch [0.48, 0.79, 0.88, 1.15, 1.44, and 1.81 mm (18, 30, 33, 43, 54, and 68 mils)]. The track legs (flanges) are 2¹/₂ inches (63.5 mm) in length and have 1/4-inch-wide-by-1¹/₂-inch-long (6.4 mm by 38 mm) vertical slots spaced 1 inch (25.4 mm) on center along the length of the section.

The CST-W deflection tracks are the same as the CST deflection tracks, except they have drift slots 2¹/₂ inches (64 mm) long spaced 4 inches (102 mm) on center staggered on either side of the centerline of the web. Six-inch-drift (152 mm) slots are available at special request for track widths of 3⁵/₈, 4, 6 and 8 inches (92, 102, 152 and 203 mm).

[Figure 1](#) provides details of the CST and CST-W sections. The CST and CST-W section designations are shown in [Table 2](#).

The allowable lateral load for the CST track is shown in [Table 3](#). The allowable lateral load for the CST-W track is shown in [Table 4](#).

The 54 and 68 mil deflection tracks are formed from steel complying with ASTM A1003 ST50H or ASTM A653 SS, Grade 50, Class 1. The 18, 30, 33 and 43 mil deflection tracks are formed from steel complying with ASTM A653 SS, Grade 33. The 18, 30, and 33 mil steel sections have a G40 or greater galvanized coating, while 43, 54, and 68 mil steel sections have G60 or greater galvanized coatings.

3.3 CST-300 and CST-325 Tracks:

The CST-300 deflection tracks are U-shaped channel sections with slotted flanges and are formed from cold-formed sheet steel. The CST-300 sections have widths of 3⁵/₈, 4, 6, and 8 inches (92, 102, 152 and 203 mm) and are cold-formed from steel having design thicknesses of 0.0346, 0.0451, 0.0566, and 0.0713 inch [0.88, 1.15, 1.44, and 1.81 mm (33, 43, 54, and 68 mils)]. The track legs (flanges) are 3 inches (76.2 mm) in length and have 1/4-inch-wide-by-2-inch-long (6.4 mm by 50.8 mm) vertical slots spaced 1 inch (25.4 mm) on center along the length of the section. The spacing from the top of the vertical slot to the web and the bottom of the slot to the end of the flange are both 1/2-inch (12.7 mm).

The CST-325 deflection tracks are the same as the CST-300 deflection tracks, except they have different flange dimensions. The CST-325 sections have widths of 3⁵/₈, 4, 6 and 8 inches (92, 102, 152 and 203 mm). The track legs (flanges) are 3-1/4 inches (82.55 mm) in length and have 1/4-inch-wide-by- 2-inch-long (6.4 mm by 50.8 mm) vertical slots spaced 1 inch (25.4 mm) on center along the length of the section. The spacing from the top of the vertical slot to the web is 1 inch (25.4 mm) and the bottom of the slot to the end of the flange 1/4 inch (6.35 mm).

[Figure 2](#) and [Figure 3](#) provide details of the CST-300 and CST-325 sections, respectively. The CST-300 and CST-325 section designations are shown in [Table 2](#).

The allowable lateral load for the CST-300 track is shown in [Table 5](#). The allowable lateral load for the CST-325 track is shown in [Table 6](#).

The 54 and 68 mil deflection tracks are formed from steel complying with ASTM A1003 ST50H or ASTM A653 SS, Grade 50, Class 1. The 33 and 43 mil deflection tracks are formed from steel complying with ASTM A653 SS, Grade 33. The 33-mil steel section has a G40 or greater galvanized coating. The 43, 54, and 68 mil steel sections have G60 or greater galvanized coatings.

3.4 Fasteners:

Fasteners used to attach the tops of the studs to the CST, CST-300, CST-325, or CST-W tracks must be minimum No. 8 by 9/16-inch-long (14.3 mm), wafer-head, self-piercing tapping or self-drilling tapping, as applicable, steel screws complying with ASTM C1513-18.

4.0 DESIGN AND INSTALLATION

The attachment of the CST, CST-300, CST-325, or CST-W tracks to the studs is accomplished by using fasteners described in Section 3.4. The screws must be installed into each side of the CST, CST-300, CST-325, or CST-W through the center of the slots designed for upward and downward movement, without affecting the positive attachment of the stud framing members. The fasteners must penetrate the stud section a minimum of three threads. There must be no attachment through the slotted track that will impair movement.

5.0 CONDITIONS OF USE:

The CEMCO CST, CST-300, CST-325, and CST-W expansion joint systems described in this report comply with, or are suitable alternatives to what is specified in, the codes noted in Section 1.0 of this report, subject to the following conditions:

- 5.1** The CST, CST-300, CST-325, and CST-W must be installed and identified in accordance with this report, the applicable code and the report holder's or additional listee's published installation instructions. In the event of a conflict between this report and the report holder's or additional listee's published installation instructions, this report governs.
- 5.2** The construction documents prepared or reviewed by a registered design professional where required by the statutes of the jurisdiction in which the project is to be constructed specifying CEMCO Slotted Tracks must indicate compliance with this evaluation report and applicable codes and must be submitted to the code official for approval.

- 5.3 The minimum uncoated steel thickness of cold-formed members, as delivered to the jobsite, must be at least 95 percent of the design base-metal thickness as specified in this report. The design of the steel studs to be used in the expansion joint systems is outside the scope of this report and must be submitted to the code official for approval.
- 5.4 Products are manufactured by the companies and locations noted in [Table 1](#) under a quality control program with inspections by ICC-ES.

6.0 EVIDENCE SUBMITTED

- 6.1 Data in accordance with the [ICC-ES Acceptance Criteria for Cold-Formed Steel Framing Members \(AC46\)](#), dated October 2019 (editorially revised December 2020).

7.0 IDENTIFICATION

- 7.1 At spacing not exceeding 96 inches (2440 mm) on center, each CST, CST-300, CST-325, and CST-W track is identified with the manufacturer's initials (CEMCO); "CST", "CST-300", "CST-325", or "CST-W", respectively; the minimum base steel thickness; the minimum yield strength (if over 33 ksi); the galvanization coating designation (if G60 or greater); the designation "NS" (if G40 is used); and the evaluation report number (ICC-ES ESR-2012). In addition, each pallet of track is identified with the report holder's company name and the section designation.
- 7.2 The report holder's contact information is the following:

CEMCO, LLC.
13191 CROSSROADS PARKWAY NORTH,
SUITE 325
CITY OF INDUSTRY, CALIFORNIA 91746
(800) 416-2278
www.cemcosteel.com

TABLE 1—MANUFACTURING LOCATIONS

MANUFACTURING LOCATION	PRODUCTS
CEMCO – City of Industry City of Industry, CA 91746	CST, CST-W
CEMCO – Pittsburg Pittsburg, CA 94565	CST, CST-W, CST-300, CST-325,
CEMCO – Denver Denver, CO 80204	CST

TABLE 2—SECTION DESIGNATIONS

CST ¹ and CST-W ²		CST-300	CST-325
250CST250-18	400CST250-54	362CST300-33	362CST325-33
250CST250-30	400CST250-68	362CST300-43	362CST325-43
250CST250-33	600CST250-18	362CST300-54	362CST325-54
250CST250-43	600CST250-30	362CST300-68	362CST325-68
250CST250-54	600CST250-33	400CST300-33	400CST325-33
362CST250-18	600CST250-43	400CST300-43	400CST325-43
362CST250-30	600CST250-54	400CST300-54	400CST325-54
362CST250-33	600CST250-68	400CST300-68	400CST325-68
362CST250-43	800CST250-18	600CST300-33	600CST325-33
362CST250-54	800CST250-30	600CST300-43	600CST325-43
362CST250-68	800CST250-33	600CST300-54	600CST325-54
400CST250-18	800CST250-43	600CST300-68	600CST325-68
400CST250-30	800CST250-54	800CST300-33	800CST325-33
400CST250-33	800CST250-68	800CST300-43	800CST325-43
400CST250-43		800CST300-54	800CST325-54
		800CST300-68	800CST325-68

¹Refer to [Table 3](#) for additional information.

²CTS-W is the CST with drift slots placed in the web except that the CST-W is not available in 2.5"width. Refer to [Table 4](#) for additional information.

TABLE 3—CST SLOTTED TRACK ALLOWABLE LOADS

MODEL NO. ¹	DESIGN THICKNESS (in)	MINIMUM THICKNESS (in)	YIELD (ksi)	COATING	WEB SIZES (in)	GAP ² (in)	ALLOWABLE LOAD ³ PER STUD (lb)	LOAD AT 1/8 INCH DEFLECTION ⁴ (lb)
18	0.0188	0.0179	33	G40	2 1/2 3 5/8 4 6 8	5/8	80	20
30	0.0312	0.0296	33	G40	2 1/2 3 5/8 4 6 8	5/8	135	45
33	0.0346	0.0329	33	G40	2 1/2 3 5/8 4 6 8	5/8	150	40
43	0.0451	0.0428	33	G60	2 1/2 3 5/8 4 6 8	5/8	220	65
54	0.0566	0.0538	50	G60	2 1/2 3 5/8 4 6 8	5/8	355	125
68	0.0713	0.0677	50	G60	3 5/8 4 6 8	5/8	380	200

For SI: 1 inch = 25.4mm, 1 lbf = 4.448 N, 1 ksi = 6.8948 kPa, 1 lb/ft = 14.5939 N/m

¹See the last two digits in the section designation in [Table 2](#).

²The gap is the maximum distance between end of the stud and the web of the track. The gap is equal to the length of the slot in the track's flange divided by 2 minus the radius of the fastener connecting the stud to the track flange through the slot [(1.5/2) - 1/8 = 5/8 inches].

³Loads are allowable strength loads (ASD). For load and resistance factor design (LRFD) multiply by 1.54.

⁴Deflection is the deflection of the edge of the flange away from the web of the CST.

TABLE 4—CST-W SLOTTED TRACK ALLOWABLE LOADS

MODEL NO. ¹	DESIGN THICKNESS (in)	MINIMUM THICKNESS (in)	YIELD (ksi)	COATING	WEB SIZES (in)	GAP ² (in)	ALLOWABLE LOAD ³ PER STUD (lb)	LOAD AT 1/8 INCH DEFLECTION ⁴ (lb)
33	0.0346	0.0329	33	G40	2 1/2 3 5/8 4 6 8	5/8	140	35
7	0.0451	0.0428	33	G60	2 1/2 3 5/8 4 6 8	5/8	210	60
54	0.0566	0.0538	50	G60	2 1/2 3 5/8 4 6 8	5/8	280	95
68	0.0713	0.0677	50	G60	3 5/8 4 6 8	5/8	365	210

For SI: 1 inch = 25.4mm, 1 lbf = 4.448 N, 1 ksi = 6.8948 kPa, 1 lb/ft = 14.5939 N/m

¹See the last two digits in the section designation in [Table 2](#).

²The gap is the maximum distance between end of the stud and the web of the track. The gap is equal to the length of the slot in the track's flange divided by 2 minus the radius of the fastener connecting the stud to the track flange through the slot [(1.5/2) - 1/8 = 5/8 inches].

³Loads are allowable strength loads (ASD). For load and resistance factor design (LRFD) multiply by 1.54.

⁴Deflection is the deflection of the edge of the flange away from the web of the CST-W.

TABLE 5—CST-300 SLOTTED TRACK ALLOWABLE LOADS (3" Flange)

MODEL NO. ¹	DESIGN THICKNESS (in)	MINIMUM THICKNESS (in)	YIELD (ksi)	COATING	WEB SIZES (in)	GAP ² (in)	ALLOWABLE LOAD ³ PER STUD (lb)	LOAD AT 1/8 INCH DEFLECTION ⁴ (lb)
33	0.0346	0.0329	33	G40	3 ⁵ / ₈ 4 6 8	7/8	140	110
43	0.0451	0.0428	33	G60	3 ⁵ / ₈ 4 6 8	7/8	250	210
54	0.0566	0.0538	50	G60	3 ⁵ / ₈ 4 6 8	7/8	520	350
68	0.0713	0.0677	50	G60	3 ⁵ / ₈ 4 6 8	7/8	760	600

For SI: 1 inch = 25.4mm, 1 lbf = 4.448 N, 1 ksi = 6.8948 kPa, 1 lb/ft = 14.5939 N/m

¹See the last two digits in the section designation in [Table 2](#).

²The gap is the maximum distance between end of the stud and the web of the track. The gap is equal to the length of the slot in the track's flange divided by 2 minus the radius of the fastener connecting the stud to the track flange through the slot [(2/2) - 1/8 = 7/8 inches].

³Loads are allowable strength loads (ASD). For load and resistance factor design (LRFD) multiply by 1.54.

⁴Deflection is the deflection of the edge of the flange away from the web of the CST-300.

TABLE 6—CST-325 SLOTTED TRACK ALLOWABLE LOADS (3.25" Flange)

MODEL NO. ¹	DESIGN THICKNESS (in)	MINIMUM THICKNESS (in)	YIELD (ksi)	COATING	WEB SIZES (in)	GAP ² (in)	ALLOWABLE LOAD ³ PER STUD (lb)	LOAD AT 1/8 INCH DEFLECTION ⁴ (lb)
33	0.0346	0.0329	33	G40	3 ⁵ / ₈ 4 6 8	7/8	150	105
43	0.0451	0.0428	33	G60	3 ⁵ / ₈ 4 6 8	7/8	260	195
54	0.0566	0.0538	50	G60	3 ⁵ / ₈ 4 6 8	7/8	510	335
68	0.0713	0.0677	50	G60	3 ⁵ / ₈ 4 6 8	7/8	770	540

For SI: 1 inch = 25.4mm, 1 lbf = 4.448 N, 1 ksi = 6.8948 kPa, 1 lb/ft = 14.5939 N/m

¹See the last two digits in the section designation in [Table 2](#).

²The gap is the maximum distance between end of the stud and the web of the track. The gap is equal to the length of the slot in the track's flange divided by 2 minus the radius of the fastener connecting the stud to the track flange through the slot [(2/2) - 1/8 = 7/8 inches].

³Loads are allowable strength loads (ASD). For load and resistance factor design (LRFD) multiply by 1.54.

⁴Deflection is the deflection of the edge of the flange away from the web of the CST-325.

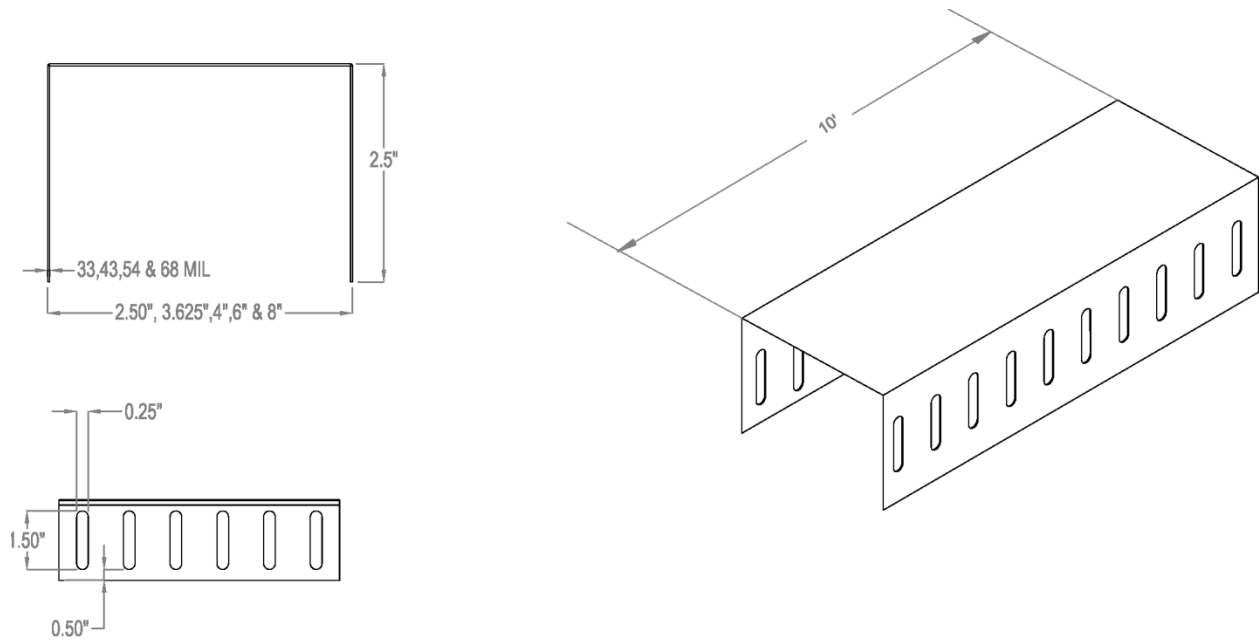

CST SLOTTED TRACK

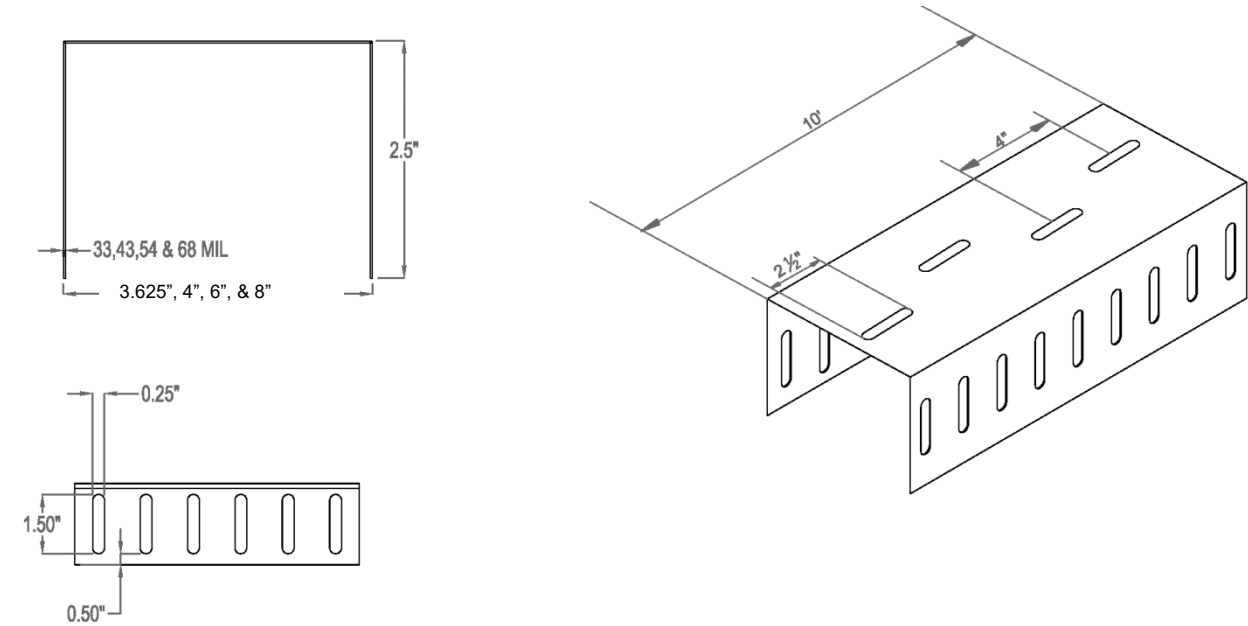

CST-W SLOTTED TRACK WITH DRIFT SLOTS

FIGURE 1—CEMCO SLOTTED TRACK WITH 2.5" FLANGE

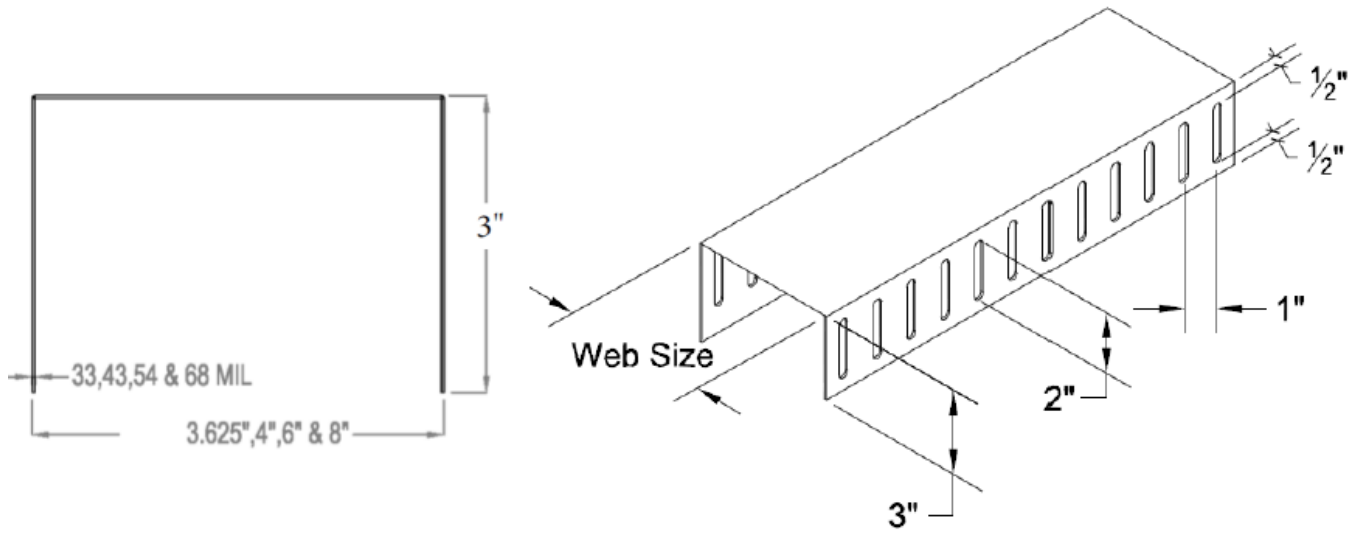

FIGURE 2—CST-300 SLOTTED TRACK WITH 3" FLANGE

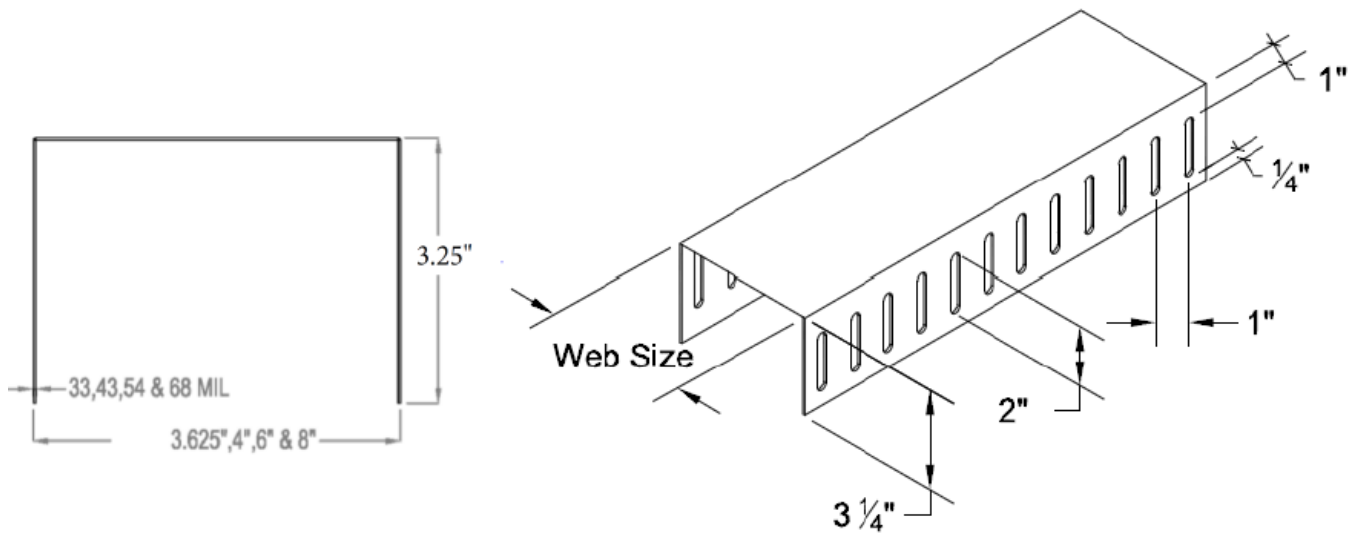

FIGURE 3—CST-325 SLOTTED TRACK WITH 3.25" FLANGE

DIVISION: 05 00 00—METALS

Section: 05 40 00—Cold-Formed Metal Framing

DIVISION: 09 00 00—FINISHES

Section: 09 22 16.13—Non-Structural Metal Stud Framing

REPORT HOLDER:

CEMCO, LLC.

EVALUATION SUBJECT:

CEMCO STEEL TRACKS EXPANSION JOINT SYSTEM FOR NONLOAD-BEARING WALL SYSTEMS

1.0 REPORT PURPOSE AND SCOPE**Purpose:**

The purpose of this evaluation report supplement is to indicate that CEMCO Steel Tracks Expansion Joint System for Nonload-Bearing Wall Systems, described in ICC-ES evaluation report [ESR-2012](#), have also been evaluated for compliance with the code noted below as adopted by the Los Angeles Department of Building and Safety (LADBS).

Applicable code edition:2023 City of Los Angeles Building Code ([LABC](#))**2.0 CONCLUSIONS**

The CEMCO Steel Tracks Expansion Joint System for Nonload-Bearing Wall Systems, described in Sections 2.0 through 7.0 of the evaluation report [ESR-2012](#), comply with the LABC Chapter 22, and are subject to the conditions of use described in this supplement.

3.0 CONDITIONS OF USE

The CEMCO Steel Tracks Expansion Joint System for Nonload-Bearing Wall Systems described in this evaluation report supplement must comply with all of the following conditions:

- All applicable sections in the evaluation report [ESR-2012](#).
- The design, installation, conditions of use and identification of the Cold-Formed Steel Framing Members are in accordance with the 2021 *International Building Code*® (IBC) provisions noted in the evaluation report [ESR-2012](#).
- The design, installation and inspection are in accordance with additional requirements of LABC Chapters 16, 17 and 22, as applicable.

This supplement expires concurrently with the evaluation report, reissued October 2025.

DIVISION: 05 00 00—METALS

Section: 05 40 00—Cold-Formed Metal Framing

DIVISION: 09 00 00—FINISHES

Section: 09 22 16.13—Non-Structural Metal Stud Framing

REPORT HOLDER:

CEMCO, LLC.

EVALUATION SUBJECT:**CEMCO STEEL TRACKS EXPANSION JOINT SYSTEM FOR NONLOAD-BEARING WALL SYSTEMS****1.0 REPORT PURPOSE AND SCOPE****Purpose:**

The purpose of this evaluation report supplement is to indicate that the CEMCO Steel Tracks Expansion Joint System for Nonload-Bearing Wall Systems, described in ICC-ES evaluation report [ESR-2012](#), has also been evaluated for compliance with the code noted below.

Applicable code edition:

2022 California Building Code (CBC)

For evaluation of applicable chapters adopted by the [California Office of Statewide Health Planning and Development \(OSHPD\) AKA: California Department of Health Care Access and Information \(HCAI\) and the Division of State Architect \(DSA\)](#)), see Sections 2.1 and 2.2 below.

2.0 CONCLUSIONS

The CEMCO Steel Tracks Expansion Joint System for Nonload-Bearing Wall Systems, described in Sections 2.0 through 7.0 of the evaluation report [ESR-2012](#), complies with CBC Chapter 22, provided the design and installation are in accordance with the 2021 *International Building Code*® (IBC) provisions noted in the evaluation report and the additional requirements of CBC Chapters 16, 17, and 22 as applicable.

2.1 OSHPD:

The CEMCO Steel Tracks Expansion Joint System for Nonload-Bearing Wall Systems, described in Sections 2.0 through 7.0 of the evaluation report [ESR-2012](#), comply with CBC amended Sections in Chapters 16, 17 and 22, and Chapters 16A, 17A and 22A provided the design and installation are in accordance with the 2021 *International Building Code*® (IBC) provisions noted in the evaluation report and the additional requirements in Sections 2.1.1 and 2.1.2 of this supplement:

2.1.1 Conditions of Use:

1. All loads applied to the cold-formed steel studs shall be determined by the registered design professional and shall comply with applicable loads from CBC amended sections in Chapters 16 and 16A.
2. Prescriptive framing is not permitted in accordance with CBC Section 2211A.1.2 [OSHPD 1 & 4].
3. In accordance with CBC Section 2211.2 and 2211A.2, for cold-formed steel light-frame construction, the design and installation of nonstructural members and connections shall be in accordance with AISI S220 for noncomposite assembly design. Where nonstructural members do not qualify for design under AISI 220, the design and installation of nonstructural members and connectors shall be in accordance with AISI S240 or S100 [OSHPD 1, 1R, 2, 4 and 5].

4. Storage racks and wall-hung cabinet loading per Table 1607.1 [OSHPD 1R, 2 and 5] and Table 1607A.1 [OSHPD 1 and 4] is excluded from this supplement.

2.1.2 Special Inspection Requirements:

1. In accordance with CBC Section 1704.2 Exception 3, special inspection is required for portions of structures designed and constructed in accordance with the cold-formed steel light-frame construction provisions of CBC 2211.1.2 [OSHPD 1R, 2, & 5].
2. Periodic special inspections shall be required in accordance with CBC Section 1705A.12.3 and 1705A.13.5 [OSHPD 1 & 4].

2.2 DSA:

The CEMCO Steel Tracks Expansion Joint System for Nonload-Bearing Wall Systems, described in Sections 2.0 through 7.0 of the evaluation report [ESR-2012](#), comply with CBC amended Sections in Chapters 16 and 22, and Chapters 16A, 17A and 22A, provided the design and installation are in accordance with the 2021 *International Building Code*[®] (IBC) provisions noted in the evaluation report and the additional requirements in Sections 2.2.1 and 2.2.2 of this supplement.

2.2.1 Conditions of Use:

1. All loads applied to the cold-formed steel studs shall be determined by the registered design professional and shall comply with applicable loads from CBC amended sections in Chapters 16 and 16A.
2. Prescriptive framing is not permitted in accordance with CBC Section 2211A.1.2 [DSA-SS].
3. In accordance with CBC Section 2211A.2, for cold-formed steel light-frame construction, the design and installation of nonstructural members and connections shall be in accordance with AISI S220 for noncomposite assembly design. Where nonstructural members do not qualify for design under AISI 220, the design and installation of nonstructural members and connectors shall be in accordance with AISI S240 or S100 [DSA-SS].
4. Storage racks and wall-hung cabinet loading per Table 1607A.1 [DSA-SS] and Section 1617.5.1.5 [DSA-SS/CC] is excluded from this supplement.

2.2.2 Special Inspection Requirements: Periodic special inspections shall be required in accordance with CBC Section 1705A.12.3 and 1705A.13.5 [DSA-SS/CC].

This supplement expires concurrently with the evaluation report, reissued October 2025