



XHBN.HW-D-0259 - Joint Systems

Design/System/Construction/Assembly Usage Disclaimer

- Authorities Having Jurisdiction should be consulted in all cases as to the particular requirements covering the installation and use of UL Certified products, equipment, system, devices, and materials.
- Authorities Having Jurisdiction should be consulted before construction.
- Fire resistance assemblies and products are developed by the design submitter and have been investigated by UL for compliance with applicable requirements. The published information cannot always address every construction nuance encountered in the field.
- When field issues arise, it is recommended the first contact for assistance be the technical service staff provided by the product manufacturer noted for the design. Users of fire resistance assemblies are advised to consult the general Guide Information for each product category and each group of assemblies. The Guide Information includes specifics concerning alternate materials and alternate methods of construction.
- Only products which bear UL's Mark are considered Certified.

XHBN - Joint Systems

XHBN7 - Joint Systems Certified for Canada

See General Information for Joint Systems

See General Information for Joint Systems Certified for Canada

System No. HW-D-0259

March 16, 2020

ANSI/UL2079	CAN/ULC S115
Assembly Ratings — 1 and 2 Hr (See Items 1 and 2)	F Ratings — 1 and 2 Hr (See Items 1 and 2)
Nominal Joint Width - 1-1/2 In.	FT Ratings — 1 and 2 Hr (See Items 1 and 2)
Class II Movement Capabilities — 50% Compression or Extension	FH Ratings — 1 and 2 Hr (See Items 1 and 2)
L Rating At Ambient — Less Than 1 CFM/lin ft	FTH Ratings — 1 and 2 Hr (See Items 1 and 2)
L Rating At 400 F — Less Than 1 CFM/lin ft	Nominal Joint Width - 1-1/2 In.
	Class II Movement Capabilities — 50% Compression or Extension
	L Rating At Ambient — Less Than 1 CFM/lin ft
	L Rating At 400 F — Less Than 1 CFM/lin ft

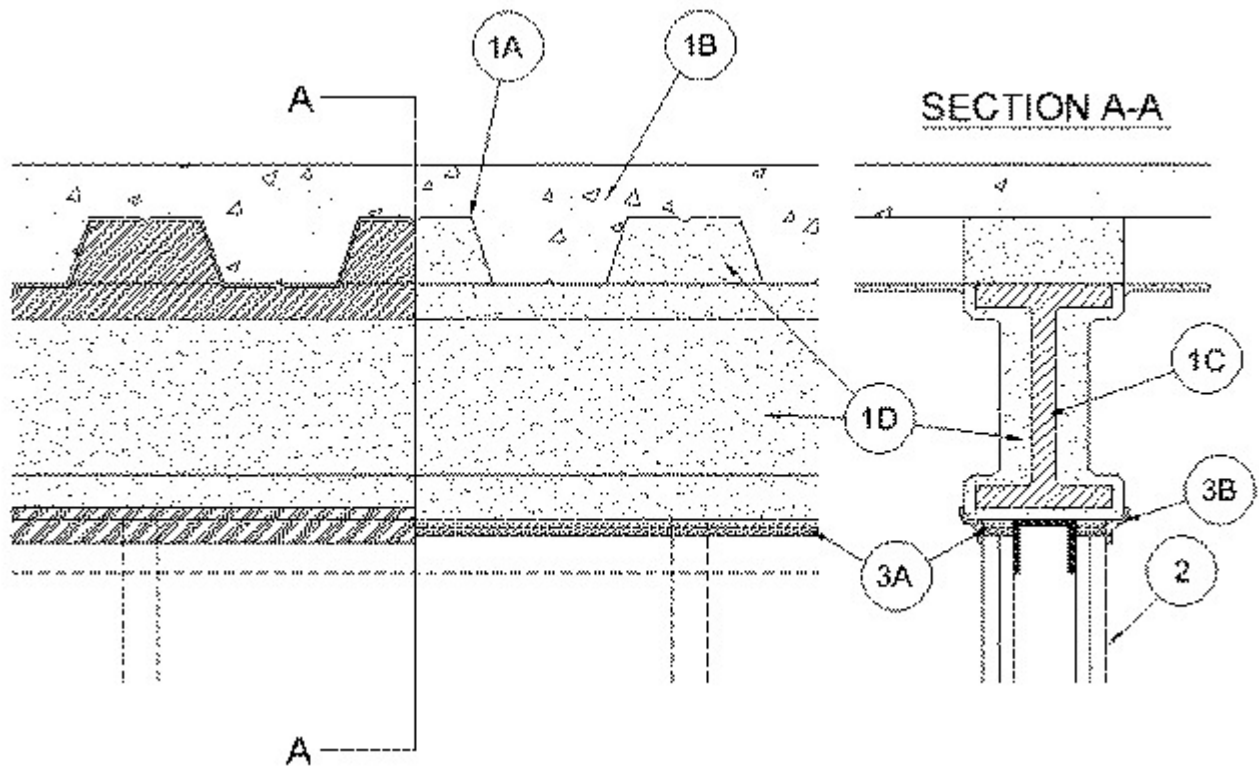

1. Floor Assembly — The fire-rated fluted steel floor unit/concrete floor assembly shall be constructed of the materials and in the manner described in the individual Floor-Ceiling Design in the Fire Resistance Directory and shall include the following construction features:

A. **Steel Floor and Form Units*** — Max 3 in. (76 mm) deep galv steel fluted floor units.

B. **Concrete** — Min 2-1/2 in. (64 mm) thick reinforced concrete, as measured from the top plane of the floor units.

C. **Structural Steel Support** — Steel beam, as specified in the individual D700 or D900 Series Floor-Ceiling Design, used to support steel floor units. Structural steel support centered over and parallel with wall assembly.

D. **Spray-Applied Fire Resistive Material*** — Steel floor units and structural steel beam to be sprayed with the thickness of material specified in the individual D700 Series Design or the structural steel supports to be sprayed in accordance with the specifications in the individual D900 Series Design. The flutes of the steel floor units are to be filled with material across the entire top flange of the steel beam. Additional material shall be applied to the web of the steel beam on each side of the wall. **For a 1 hr Assembly Rating, the total thickness of material applied to each side of the steel beam web shall be min 13/16 in. (21 mm). For a 2 hr Assembly Rating, the total thickness of material applied to each side of the steel beam web shall be min 1-3/8 in. (35 mm).**

GCP APPLIED TECHNOLOGIES INC — Types MK-6-HY or MK-10HB

D1. **Spray-Applied Fire Resistive Material*** — Steel floor units and structural steel support to be sprayed with the min thickness of material specified in the individual D700 or D900 Series Design. The flutes of the steel floor units are to be filled with material across the entire top flange of the steel beam. **Additional material shall be applied to the web of the steel beam on each side of the wall. For a 1 hr Assembly Rating, the total thickness of material applied to each side of the steel beam web shall be min 11/16 in. (18 mm). For a 2 hr Assembly Rating, the total thickness of material applied to each side of the steel beam web shall be min 1-1/2 in. (38 mm).**

ISOLATEK INTERNATIONAL — Type 300

2. Wall Assembly* — The 1 or 2 h fire rated gypsum board/stud wall assembly shall be constructed of the materials and in the manner specified in the individual U400, V400 or W400 Series Wall and Partition Design in the UL Fire Resistance Directory and shall include the following construction features:

A. **Steel Floor and Ceiling Runners** — Floor and ceiling runners of wall assembly shall consist of min No. 25 gauge galv steel channels sized to accommodate steel studs (Item 2B). Flange height of ceiling runner shall be min 1/4 in. (6 mm) greater than max extended joint width. Ceiling runner centered beneath and parallel with steel beam (Item 1C). Ceiling runner secured to steel beam through spray-applied fire resistive material with steel fasteners spaced max 24 in. (610 mm) OC.

A1. **Light Gauge Framing*** — Slotted Ceiling Runner As an alternate to the ceiling runner in Item 2A, slotted ceiling runner to consist of galv steel channel with slotted flanges sized to accommodate steel studs (Item 2B). Slotted ceiling runner centered beneath and parallel with steel beam (Item 1C). Slotted ceiling runner secured to steel beam with steel fasteners, steel fasteners or welds spaced max 24 in. (610 mm) OC.

BRADY CONSTRUCTION INNOVATIONS INC, DBA SLIPTRACK SYSTEMS — SLP-TRK, SLPTRK325

CALIFORNIA EXPANDED METAL PRODUCTS CO — CST, CST325

CLARKDIETRICH BUILDING SYSTEMS — Type SLT, SLT-H

MARINO/WARE, DIV OF WARE INDUSTRIES INC — Type SLT

RAM SALES L L C — RAM Slotted Track

SCAFCO STEEL STUD MANUFACTURING CO

TELLING INDUSTRIES L L C — True-Action Deflection Track

A2. **Light Gauge Framing*** — Vertical Deflection Ceiling Runner As an alternate to the ceiling runners in Item 2A and 2A1, vertical deflection ceiling runner to consist of galv steel channel with slotted vertical deflection clips mechanically fastened within runner. Slotted clips, provided with step bushings, for permanent fastening of steel studs. Flanges sized to accommodate steel studs (Item 2B). Vertical deflection ceiling runner centered beneath and parallel with steel beam (Item 1C). Vertical Deflection ceiling runner secured to steel beam with steel fasteners, steel fasteners or welds spaced max 24 in. (610 mm) OC.

A3. **Light Gauge Framing*- Notched Ceiling Runner** — As an alternate to the ceiling runners in Items 2A through 2A2, notched ceiling runners to consist of C-shaped galv steel channel with notched return flanges sized to accommodate steel studs (Item 2B). Notched ceiling runner installed perpendicular to direction of fluted steel deck and secured to valleys with steel masonry anchors, steel fasteners or welds spaced max 24 in. (610 mm) OC.

OLMAR SUPPLY INC — Type SCR

A4. **Light Gauge Framing* — Slotted Ceiling Runner** — As an alternate to the ceiling runner in Item 2A through 2A3, ceiling runner to consist of galv steel channel with slotted flanges sized to accommodate steel studs (Item 2B). Flange height of slotted ceiling runner shall be 3-1/4 in. (83 mm) with 2 in. (51 mm) deep slots. Slotted ceiling runner centered beneath and parallel with steel beam (Item 1C). Slotted ceiling runner secured to steel beam with steel fasteners or welds spaced max 24 in. (610 mm) OC.

SCAFCO STEEL STUD MANUFACTURING CO — Slotted Track-Type SDLT

B. **Studs** — Steel studs to be min 3-1/2 in. (89 mm) wide. Studs cut 3/4 in. to 1-1/4 in. (19 to 32 mm) less in length than assembly height with bottom nesting in, resting on and fastened to the floor runner and with top nesting in ceiling runner without attachment. When slotted ceiling runner (Item 2A1) is used, steel studs secured to slotted ceiling runner with No. 8 by 1/2 in. (13 mm) long wafer head steel screws at midheight of slot on each side of wall. When vertical deflection runner (Item 2A2) is used, studs secured to vertical clip through slip bushing, supplied, with No.8 by 1/2 in. (13 mm) steel screws at mid-height of slot of each slot. Stud spacing not to exceed 24 in. (610 mm) OC. When slotted

ceiling runner (Item 2A4) is used, steel studs cut in lengths 3/4 to 1-3/4 in. (19 to 44 mm) less than floor to ceiling height and secured to slotted ceiling runner with No. 8 by 1/2 (13 mm) long wafer head steel screws at +/- 3/16 in. (5 mm) of the mid-height of slot on each side of wall.

C. **Gypsum Board*** — 5/8 in. (16 mm) thick, 4 ft (1.22 m) wide with square or tapered edges. The gypsum board type, number of layers and sheet orientation shall be as specified in the individual U400 or V400 Series Design in the Fire Resistance Directory, except that a max 1-1/2 in. (38 mm) gap shall be maintained between top edge of the gypsum board and the spray applied fire resistive material on the structural steel support. The top row of screws shall be installed into the studs 1-1/2 in. (38 mm) below the bottom of the ceiling runner.

D. **Steel Attachment Clips** — (Optional - Not Shown) - As an alternate to steel fasteners, ceiling runner secured to steel beam with Z-shaped clips formed from min 1 in. (25 mm) long strips of min 20 ga galv steel. Length of clips should not exceed the width (thickness) of the wall. Clips to be sized to extend through the thickness of the spray-applied fire-resistive material on the bottom flange of the steel beam with 1-1/2 or 2 in. (38 or 51 mm) long upper and lower legs. Legs of clips fastened to bottom of beam (prior to application of spray-applied fire-resistive materials) and top of ceiling runner with steel fasteners or welds. Clips spaced max 24in. (610 mm) OC.

The hourly ratings of the joint system are dependent on the hourly rating of the wall.

3. Joint System — Max separation between bottom of spray-applied fire resistive material on beam and top of gypsum board at time of installation is 1-1/2 in. (38 mm). The joint system is designed to accommodate a max 50 percent compression or extension from its installed width. The joint system consists of a forming material and a fill material between the top of the gypsum board and the bottom of the spray-applied fire resistive material on the beam, as follows:

A. **Forming Material*** — Nominal 4 pcf (64 kg/m³) mineral wool forming material cut into strips to fill the gap between top of the gypsum board and bottom of beam. Width of the strips shall be equal to the total thickness of the gypsum board. The strips of mineral wool shall be compressed 50 percent in thickness and firmly packed into the gap between the top of gypsum board and bottom of beam.

ROCK WOOL MANUFACTURING CO — Delta Board

ROCKWOOL — SAFE

THERMAFIBER INC — Type SAF

A1. **Forming Material* - Strips** — (Optional) - Nom 5/8 in. (16 mm) and 1-1/4 in. (32 mm) wide by 2 in. (51 mm) high precut mineral wool strips for 1 and 2 hr rated assemblies respectively. The strips are compressed 50 percent and firmly packed, cut edge first, into the gap between the top of the gypsum board and bottom of the steel floor units on both sides of the wall.

HILTI CONSTRUCTION CHEMICALS, DIV OF HILTI INC — CP 767 Speed Strips

B. **Fill, Void or Cavity Material*** — Min 1/16 in. (1.6 mm) dry thickness (min 1/8 in. or 3.2 mm wet thickness) of fill material sprayed or troweled on each side of wall to completely cover mineral wool forming material and to overlap 1/2 in. (13 mm) onto gypsum board and 2 in. (51 mm) onto spray-applied fire resistive material on the structural steel support.

HILTI CONSTRUCTION CHEMICALS, DIV OF HILTI INC — CP672 Firestop Spray or CFS-SP WB Firestop Joint Spray

*** Indicates such products shall bear the UL or cUL Certification Mark for jurisdictions employing the UL or cUL Certification (such as Canada), respectively.**

Last Updated on 2020-03-16

The appearance of a company's name or product in this database does not in itself assure that products so identified have been manufactured under UL's Follow-Up Service. Only those products bearing the UL Mark should be considered to be Certified and covered under UL's Follow-Up Service. Always look for the Mark on the product.

UL permits the reproduction of the material contained in the Online Certification Directory subject to the following conditions: 1. The Guide Information, Assemblies, Constructions, Designs, Systems, and/or Certifications (files) must be presented in their entirety and in a non-misleading manner, without any manipulation of the data (or drawings). 2. The statement "Reprinted from the Online Certifications Directory with permission from UL" must appear adjacent to the extracted material. In addition, the reprinted material must include a copyright notice in the following format: "© 2020 UL LLC"