

Fire protection for
townhouses that share
a common wall



Area Separation Wall Systems



Area separation walls between adjoining townhouses must provide fire-resistive ratings to ensure the safety of occupants in adjacent dwellings. Noise attenuation is also important, to ensure that townhouse dwellers are not disturbed by sound from their neighbors.



Fire and Sound Separation

User's Guide

This brochure explains:

- Where area separation walls are used
- The components of area separation wall systems
- How to select and specify the appropriate components of an area separation wall system

	Pages	
Understand Your System	4	Overview Applications Components Performance Testing
Select Your System	10	Design Details
Design Your System	12	Good Design Practices
Specify Your System	13	Application Guide Specifications
For More Information		Technical Service 800 USG.4YOU Websites usg.com usgdesignstudio.com

Overview

Effective fire resistance and sound attenuation are important considerations in townhouse design.

An area separation wall can be used in townhouses up to four stories (44') tall and with all common floor-ceiling heights^a. It must either be continuous from the foundation to the underside of the protected roof sheathing, or continue through the roof to form a parapet.

The area separation wall is designed to allow for collapse of the construction on the fire-exposed side, without collapse of the entire wall. To do this, aluminum breakaway clips attach the separation wall to the adjacent framing. When one side of the separation wall is exposed to fire, the clips are designed to soften and break away. This allows the structure on the fire side of the separation wall to collapse, while the clips on the unexposed side of the separation wall continue to support the separation wall. The area separation wall remains intact, protecting the adjacent townhouse.

Note

(a) System has been fire tested up to 66'. Please consult your USG representative for information.

Typical Area Separation Wall Assembly

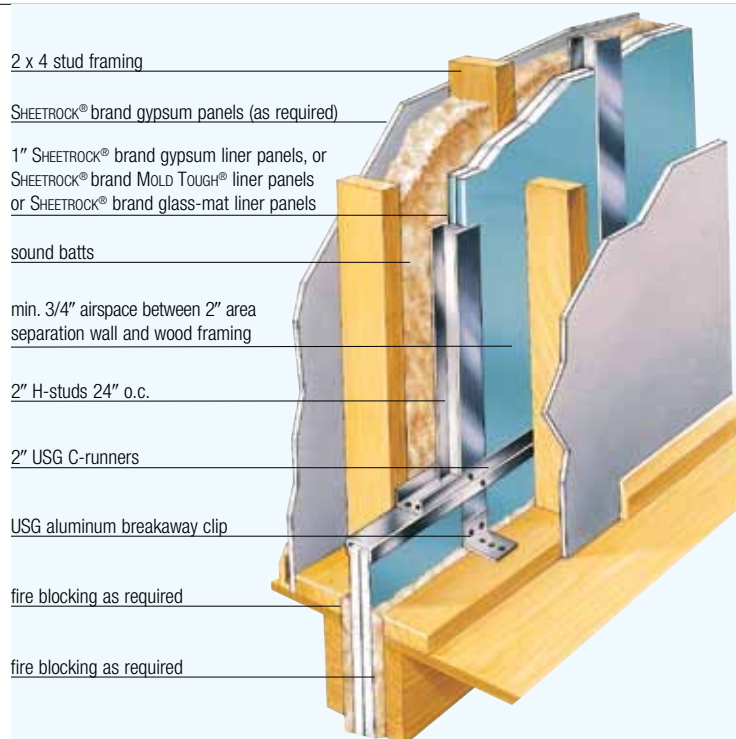

Applications

USG area separation wall systems are lightweight, non-load-bearing gypsum panel partition assemblies used to provide fire-resistive protection for common walls in townhouse construction.

These systems install quickly and easily. Because they weigh at least 50% less than masonry walls, installation proceeds rapidly. In addition, use of these assemblies gains valuable floor space for the building interior, because thickness is 3-1/2" compared to 8" to 12" for a masonry wall without interior finish.

Components

USG area separation wall systems have been comprehensively tested for fire resistance ratings only when all of the system components are used together. Substitutions of any of the components are not recommended and are not supported by USG. Refer to the appropriate product material safety data sheet for complete health and safety information.

Gypsum Liner Panels

SHEETROCK® Brand Gypsum Liner Panels

- Noncombustible core encased in water-resistant 100% recycled green face and back paper
- UL/ULC Classified for fire resistance (type SLX)
- Panels are 1" thick and 24" wide with beveled edges and are available in 8'-12' lengths
- Refer to product submittal sheet WB2278 for complete information

SHEETROCK® BRAND MOLD TOUGH® Gypsum Liner Panels

- Noncombustible core encased in a moisture- and mold-resistant, 100% recycled blue face and back paper
- UL/ULC Classified for fire resistance (type SLX)
- Panels are 1" thick and 24" wide with beveled edges and are available in 8'-12' lengths
- Refer to product submittal sheet WB2313 for complete information

SHEETROCK® Brand Glass-Mat Liner Panels

- Noncombustible core encased in moisture- and mold-resistant green glass-mat
- Direct substitute for SHEETROCK gypsum liner panels or SHEETROCK MOLD TOUGH liner panels where prolonged weather exposure is anticipated
- UL/ULC Classified for fire resistance (type SLX)
- Panels are 1" thick and 24" wide with beveled edges and are available in 8'-12' lengths
- Refer to product submittal sheet WB2483 for complete information

Metal Framing Components

USG® Steel C-Runner, USG Steel H-Stud

- Galvanized steel (G40) per ASTM A1003

USG Aluminum Breakaway Clip

- Performs as a breakaway fuse by melting or yielding from the rise in temperature on the fire side of the wall
- Allows the fire-engulfed structure to collapse independent of the area separation wall

Related Products

SHEETROCK® Acoustical Sealant

- Highly elastic, water-based sealant
- Refer to product submittal sheet J678 for complete information

SHEETROCK® All Purpose Joint Compound

- Versatile performer: tape, finish, texture, laminate or skim coat
- Combines single-package, ready-mixed convenience with good taping and topping performance
- Refer to product submittal sheet J60A for complete information

Performance Testing

USG area separation wall systems have been independently tested to meet performance requirements for fire resistance, structural performance and sound control.

Performance Tests

Extensive testing and continuous improvements ensure that USG area separation wall systems will provide the vertical fire resistance and sound performance that projects demand.

Testing Methods

USG area separation wall systems have been tested to ensure long-term performance. All USG products and systems undergo exhaustive testing to ensure that they meet exacting standards. USG products are Classified as to fire resistance and fire-hazard properties. As part of this protocol, Underwriters Laboratories Inc. (UL) periodically audits production of these materials to ensure compliance with necessary properties. UL is an independent, not-for-profit product safety testing and certification organization that has tested products for public safety for over a century.

Products and systems are tested in accordance with ASTM standards. ASTM International is one of the largest voluntary standards development organizations in the world, and it is a trusted source for technical standards for materials, products, systems and services. Sound Transmission Class (STC) rates the effectiveness of walls and other components at blocking airborne sound.

Testing Results

Fire Protection

In the event of a fire, area separation walls must ensure that fire does not spread from one townhouse to the next. Building codes mandate that area separation walls are fire tested according to specific test standards, such as ASTM E119, "Standard Test Method for Fire Tests of Building Construction and Materials," or its equivalent.

Fire resistance testing ensures that this critical performance component will not be compromised when the system is properly installed. Fire testing results in the following:

- UL Classification of all gypsum panel components for fire resistance
- UL listing of system fire resistance for 2 hours

Sound Control

Sound control test data demonstrate the effectiveness of USG area separation wall systems in attenuating sound. This means that occupants of adjacent buildings will have more privacy. STC ratings up to 60 are available.

Moisture/Mold

The best way to minimize damage from moisture and mold is to minimize or eliminate exposure to water before, during and after construction. In all cases where moisture intrusion occurs, eliminate all sources of moisture immediately.

SHEETROCK MOLD TOUGH gypsum liner panels have a noncombustible, moisture- and mold-resistant core encased in a moisture- and mold-resistant, 100% recycled blue face and black paper. SHEETROCK glass-mat liner panels have a noncombustible, moisture- and mold-resistant gypsum core that is encased in a moisture- and mold-resistant glass-mat. When used in conjunction with good construction practices, these products will minimize, but not eliminate, the risk of moisture and mold damage.

For more information on moisture and mold control, visit the following websites:

New York City Department of Health
ci.nyc.ny.us/html/doh
Search for mold resources.

United States Environmental Protection Agency
epa.gov
Search for mold resources.

Responsible Solutions to Mold Coalition
responsiblemoldsolutions.org



Performance Testing

Sustainability

The LEED® (Leadership in Energy and Environmental Design) program is a guideline for building solutions established by the U.S. Green Building Council (USGBC).

LEED's mission is to transform the building industry by establishing a common standard of measurement to define what constitutes a "green building." To this end, LEED provides a framework for assessing building performance and meeting sustainability goals. This framework assigns points for certain sustainability criteria, such as sustainable site development, water savings, energy efficiency, materials selection and indoor environmental quality.

Specific products cannot be LEED-certified, because there are many contingent factors in each project that must be considered. However, certain products may assist you in obtaining LEED points for your design solution. For example:

USGBC LEED Credits	MR 2
Construction Waste Management	2.1 Divert 50% of project waste (by weight) from landfill (1 point)
	2.2 Divert another 25% of project waste (by weight) from landfill (1 point)
Recycled Content	MR 4
	4.1 10% of building materials must be recycled material, based on the cost of the total value of the materials in the project (1 point)
	4.2 Another point is awarded for an additional 10% of recycled material (1 point)
Local/Regional Materials	MR 5
	5.1 If 10% of project materials are manufactured within 500 miles (1 point)
	5.2 If 20% of project materials are manufactured within 500 miles (1 point)

Using products with a high recycled content is only one part of the equation. Another key measure of sustainability is embodied energy, which assesses the total energy required to produce a particular material or building component and get it to a building site. For example, if you use a product with a high recycled content but need to ship it across the country, the embodied energy costs of transportation may outweigh any environmental advantages of using a recycled product. It may be more environmentally sound to ship products made of virgin material from a plant close to a job site.

To generate a customized report, visit the USG Design Studio LEED Report Tool, at usgdesignstudio.com. For more information about the sustainability of USG products, visit the [EcoBlueprint section on usg.com](http://usg.com).

For more information on USGBC and LEED, visit the following websites:

U.S. Green Building Council
usgbc.org

Leadership in Energy & Environmental Design
usgbc.org/leed/leed_main.asp

Performance Selector

All details, specifications and data contained in this literature are intended as a general guide. These products must not be used in a design or construction of any given structure without complete and detailed evaluation by a qualified structural engineer or architect to verify suitability of a particular product for use in the structure.

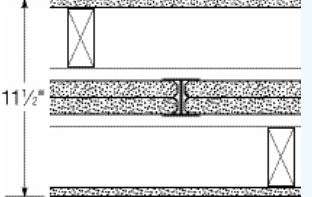
2-Hour Fire-rated Construction	Non-load-bearing	Acoustical Performance		Reference		
Construction Detail	Description	Test Number	STC		ARL	Index
 <p>3 1/2"</p>	<ul style="list-style-type: none"> 1" SHEETROCK gypsum liner panels 2" USG H-studs 24" o.c. <p>– minimum 3/4" air space both sides separating liner panels from <i>adjacent construction</i></p>	<p>UL Des U336</p>			SA925	1
 <p>1 1/2"</p>	<p>Separation wall (non-load-bearing)</p> <ul style="list-style-type: none"> 1" SHEETROCK gypsum liner panels 2" USG H-studs 24" o.c. <p>Protected wall (bearing or non-load-bearing) of wood or steel studs each side min 3/4" from liner panels</p> <ul style="list-style-type: none"> 1/2" SHEETROCK gypsum panels 	<p>UL Des U336</p>	46	RAL-TL-88-353	SA925	2
			54	RAL-TL-88-348 Based on 2" mineral wool batt on one side		
			57	RAL-TL-88-351 Based on 2x4s and 3" mineral wool batt one side		
			58	RAL-TL-88-347 Based on 2x4s and 2" mineral wool batt on both sides		
			60	RAL-TL-88-350 Based on 2x4s and 3" mineral wool batt on both sides		

Design Details

Basic Interfaces

Intersection at Roof

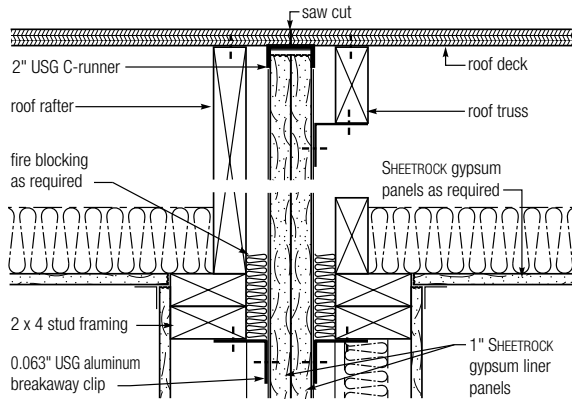

Exterior Wall Intersection (as required)

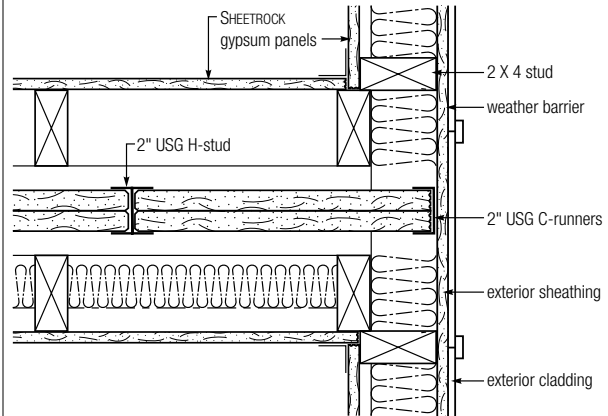

Intermediate Floor

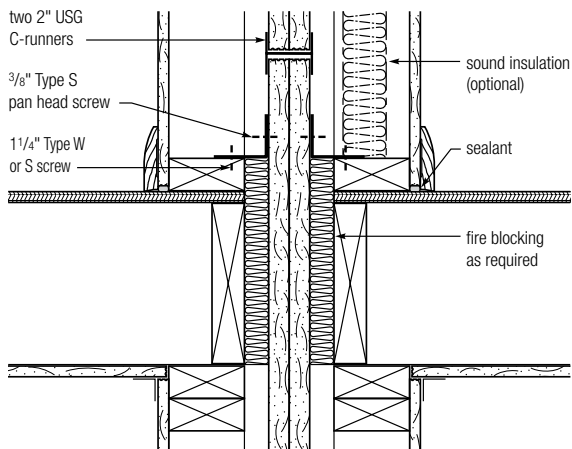

Foundation

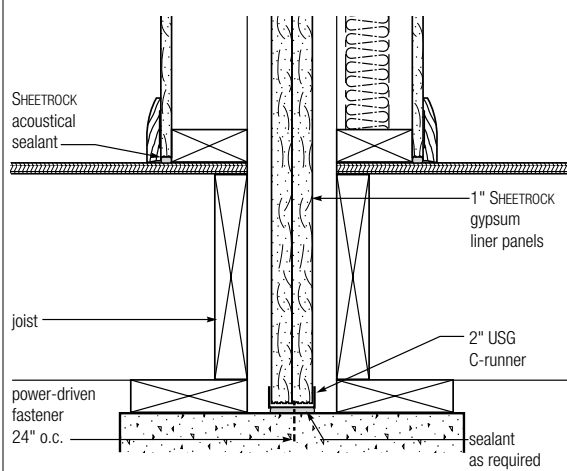

Runner Installation

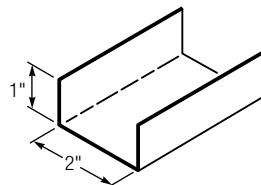
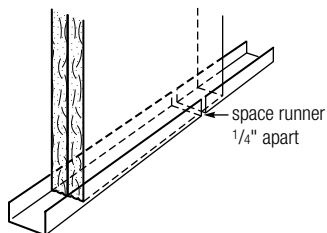

USG C-runner

Components

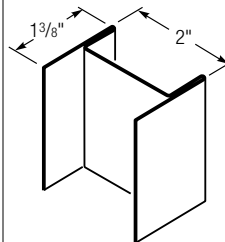

USG H-stud

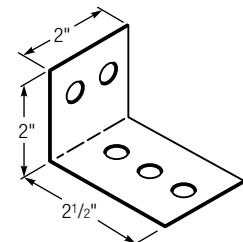

.063" USG aluminum breakaway clip

Clip Spacing Requirements

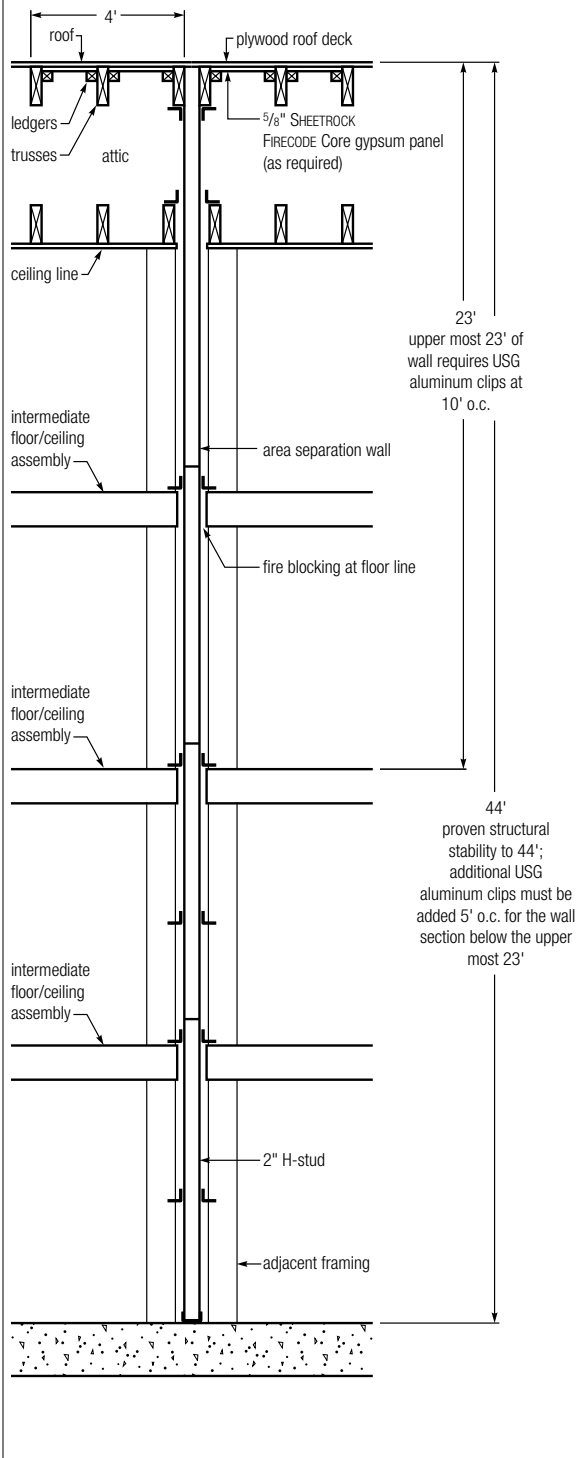

Notes

As allowed by code, 5/8" SHEETROCK FIRECODE Core gypsum panels may be used as underlayment to roof sheathing with panels extending 4' on both sides of area separation wall and possibly roof side at rake end. Clip placement on page 10 is for typical construction. System has been fire tested up to 66'. Please consult your USG representative for information.

Good Design Practices

Use this section as a reference if questions arise during the design or application of USG area separation wall systems.

This section is an overview of good design, application, installation and safety considerations that should be addressed when USG products and systems are used. This section outlines some major issues, but is not intended to be a comprehensive review.

We recommend that architects and contractors seek the assistance of safety professionals, especially at the professional construction site, because there are many factors to consider that are not included here. For safety and material handling information, please refer to Chapter 13 of *The Gypsum Construction Handbook*.

1	System Performance	USG conducts tests on products and systems to meet performance requirements of established test procedures specified by various agencies. Upon written request we will provide test certification for published fire, sound, structural and other pertinent data covering systems designed and constructed according to our published specifications. Substitutions of any of the components are not recommended and are not supported by USG.
2	Liner Panel Substitution	Note that in partitions indicating the use of SHEETROCK gypsum liner panels, it is permissible to substitute SHEETROCK MOLD TOUGH liner panels or SHEETROCK glass-mat liner panels without compromising the fire rating.
3	Sound Control Construction	For maximum sound control with wall systems, seal the entire perimeter and between the horizontal, back-to-back C-runners at the intermediate levels with a minimum 1/4" bead of SHEETROCK acoustical sealant.
4	Limitations	For use as a common 2-hour fire-resistance-rated wall separating townhouses. Not to be used for shear walls.
5	Additional Information	See SA100, <i>Fire-Resistant Assemblies</i> , for fire- and sound-rated systems; SA200, <i>Acoustical Assemblies</i> , for sound-rated systems; and SA934, <i>Moisture-Resistant Assemblies</i> , for information on moisture resistance.

Application Guide

Specifications

This guide specification is provided to assist you in specification of USG area separation wall systems. If you have additional questions or would like more information regarding this or other USG products and systems, please contact USG at 800 USG.4YOU.

Part 1: General

1.1 Scope

Specify to meet project requirements.

1.2 Qualifications

- A. All materials, unless otherwise indicated, shall be manufactured by USG, and shall be installed in accordance with its current printed directions.
- B. System must be built in accordance with applicable model code research reports.

1.3 Delivery and Storage of Materials

All materials shall be delivered in their original unopened packages and stored in an enclosed shelter providing protection from damage and exposure to the elements. Damaged or deteriorated materials shall be removed from the premises. Installed panels should be protected from the environment and dry before enclosing the wall.
Warning: Store all SHEETROCK gypsum panels flat. Panels are heavy and can fall over, causing serious injury or death. Do not move unless authorized. Use caution not to exceed floor limits or cause tripping hazards.

1.4 Environmental Conditions

In cold weather during gypsum panel joint finishing, temperature within the building shall be maintained within the range of 55 to 70° F (13 to 21° C). Adequate ventilation shall be provided to carry off excess moisture. Storage and installation of products must be protected at all times from adverse environmental conditions and elements.

Part 2: Products

2.1 Materials

- A. 1" SHEETROCK gypsum liner panels (MOLD TOUGH and glass-mat), 24"-wide, beveled-edge lengths as required.
- B. USG Steel H-studs (200HS25), galvanized, lengths as required.
- C. USG Steel C-runners (200CR25) galvanized, x 10' length.
- D. USG aluminum angle clip—2" x 2-1/2" x 0.063" aluminum breakaway clips.
- E. Joint treatment—Select a USG joint system.
- F. Fasteners—Screws (1-1/4" Type W) (1-1/4" Type S) (3/8" Type S, pan head).
- G. Sound batts 1", 1-1/2", 2" or 3" x 16" or 24" x 48".
- H. SHEETROCK acoustical sealant.

Part 3: Execution

3.1 Solid Wall

A. Foundation

Position 2" C-runner and securely attach to foundation with power-driven fasteners at both ends and spaced 24" o.c. Space adjacent runner sections 1/4" apart. Caulk under runner at foundation with a minimum of 1/4" bead of acoustical sealant.

B. First Floor

Install H-studs and liner panels to a convenient height (max. 2') above the floor line. Install two thicknesses of 1" liner panels vertically in C-runner with long edges in H-stud. Install H-studs and liner panels alternately until wall is completed. Cap top of panels with horizontal C-runner. Fasten C-runner flanges at all corners both sides with 3/8" Type S screws.

C. Intermediate Floors and Bottom of Trusses

Cap top of liner panels and H-studs with C-runner. Attach C-runner for next row of panels to the C-runner below with end joints staggered at least 12". Fasten the C-runners together with double 3/8" screws at ends and 24" o.c. Attach all H-studs and vertical C-runners to adjacent framing with aluminum breakaway clips. Clips attaching H-studs and vertical C-runners to adjacent framing on both sides require attachment to the H-stud and C-runner with one 3/8" Type S screw. Clips attaching H-studs and vertical C-runners to adjacent framing on only one side and with exterior exposure on the other side require attachment to the H-stud and C-runner with two 3/8" Type S screws. Attachment to the adjacent framing is with one 1-1/4" Type W or Type S screw. Locate horizontal C-runner joint within 2' of the intermediate floor. Install fire blocking between the solid wall system and adjacent framing at floor lines, bottom of truss line, and any other locations required by the applicable code.

D. Roof

Continue installing H-studs and liner panels for succeeding stories as described. Cut the liner panels and H-studs to roof pitch and length as necessary to follow the roof pitch. At roof, cap liner panels and H-studs with C-runner. Attach all H-studs to adjacent framing with aluminum breakaway clips. Clips attaching H-studs and vertical C-runners to adjacent framing on only one side and with exterior exposure on the other side require attachment to each vertical framing member with two 3/8" Type S screws.

3.2 Exterior Wall

USG area separation wall systems are suitable for exterior walls with an appropriate weather barrier installed over the system and under an exterior cladding. Exterior exposure is limited to 15 psf wind load and requires vertical clip spacing of 4' o.c. maximum. Exterior exposure requires attachment of the aluminum breakaway clips to each vertical steel framing member with two 3/8" Type S screws. Attachment of the clips to adjacent framing is with one 1-1/4" Type W or Type S screw. Uppermost clips should be placed as close to the roof line as practical attachment allows.

About the cover:

Project

Townhomes at Meridian Square

Indianapolis, IN

Design and Construction

Ryland Homes

Photographer

©Albert Vecerka/Esto



Technical Service

800 USG.4YOU

Websites

usg.com
usgdesignstudio.com

Samples/Literature

888 874.2450

Samples/Literature E-mail

samplit@usg.com

Samples/Literature Fax

888 874.2348

Customer Service

800 950.3839

Product Information

See usg.com for the most up-to-date product information.

Metric Specifications

USG Corporation, through its operating subsidiaries, will provide metric conversions on its products and systems to help specifiers match metric design sizes. In addition, some products are available in metric dimensions from selected manufacturing plants. Refer to SA100, *Fire-Resistant Assemblies*, for additional information and a Table of Metric Equivalents.

Trademarks

The following trademarks used herein are owned by United States Gypsum or a related company: FIRECODE, MOLD TOUGH, SHEETROCK, USG. LEED is a registered trademark of the U.S. Green Building Council.

Notice

We shall not be liable for incidental and consequential damages, directly or indirectly sustained nor for any loss

caused by application of these goods not in accordance with current printed instructions or for other than the intended use. Our liability is expressly limited to replacement of defective goods. Any claim shall be deemed waived unless made in writing to us within thirty (30) days from the date it was or reasonably should have been discovered.

Note

All products described here may not be available in all geographic markets. Consult your local sales office or representative for information.

Safety First!

Follow good safety and industrial hygiene practices during handling and installation of all products and systems. Take necessary precautions and wear the appropriate personal protective equipment as needed. Read material safety data sheets and related literature on products before specification and/or installation.

